



## TBE

### Construction

Belt driven type. Double flanged casing is produced in mild steel or galvanised steel. The impeller with manually adjustable pitch blades is made of PPG, PAG or Aluminium.

### Finish

Painting or galvanised finish after manufacture is standard on all parts.

### Operating Temperature

-20°C to +85°C

### Motors

Total Enclosed Fan Cooled (TEFC), Class "F", IP54 protection. Standard motors up to 2.2kW are supplied with DOL starting. Motors 3.0kW and above are with star/delta starting. Motors of other specification are available upon request.

### Airflow Direction

Air flowing from impeller to motor is fitted as standard. Air flow from motor to impeller can be supplied upon request.

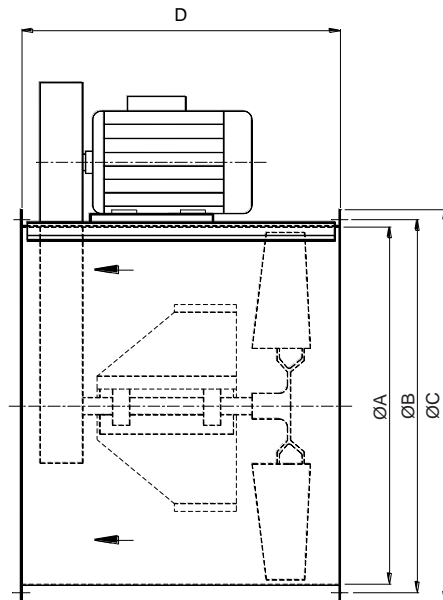
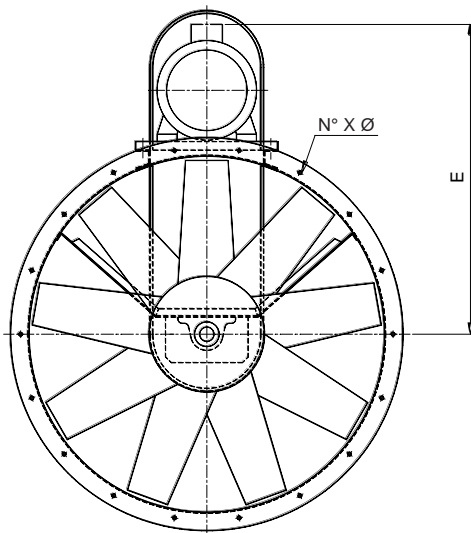

All Dimension in mm.

MODEL	A	B	C	D	E		N°	Ø	Weight (kg)	Max.Motor* FrameSize
					Min	Max				
315	315	355	395	475	380	440	8	10	15	D90L
355	355	395	435	475	400	460	8	10	17	D90L
400	400	440	480	475	445	485	12	10	19	D90L
450	450	490	530	475	470	540	12	10	21	D90L
500	500	540	580	560	500	590	12	10	31	D112M
560	560	605	660	560	570	650	12	10	36	D112M
630	630	675	730	710	610	680	12	10	44	D132M
710	710	755	810	710	650	725	18	12	64	D132M
800	800	845	900	710	700	775	18	12	72	D132M

MODEL	A	B	C	D	E		N°	Ø	Weight (kg)	Max.Motor* FrameSize
					Min	Max				
900	900	945	1000	750	750	825	18	12	83	D132M
1000	1000	1050	1100	750	810	885	24	12	93	D132M
1120	1120	1185	1250	1000	845	985	24	12	170	D180L
1250	1250	1315	1380	1120	930	1175	24	12	220	D200L
1400	1400	1465	1530	1120	1015	1335	32	14	330	D225M
1600	1600	1663	1730	1180	1155	1485	32	14	447	D250M
1800	1800	1856	1930	1250	1380	1640	32	14	630	D250M
2000	2000	2073	2130	1320	1475	1735	32	14	1150	D250M

\* Please consult KRUGER if motor frame size is beyond the catalogue range --- Weight without motor and impeller.

## 2 POLES - 2800 RPM

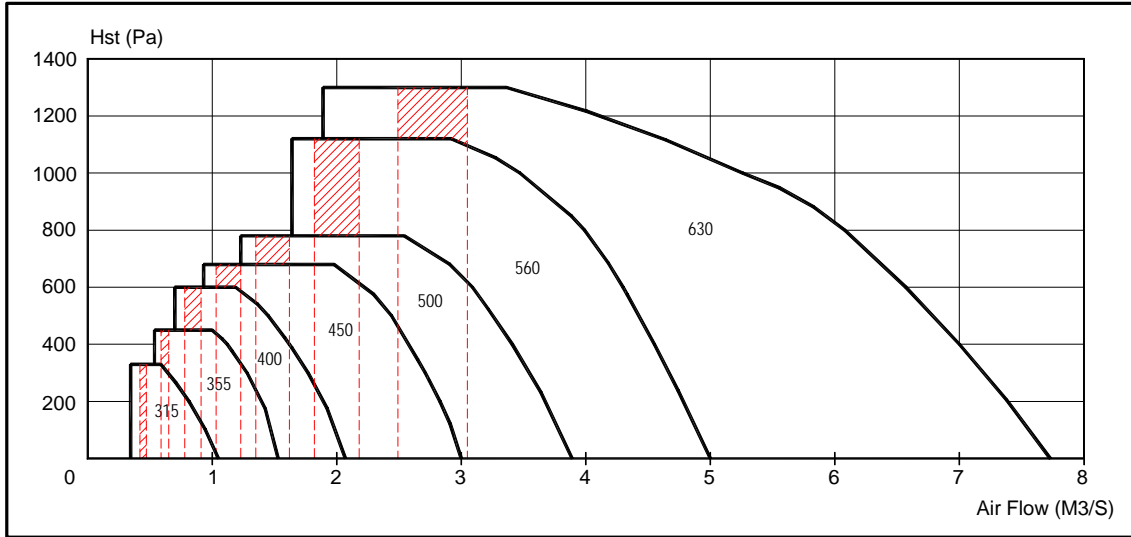

## 4 POLES - 1420 RPM

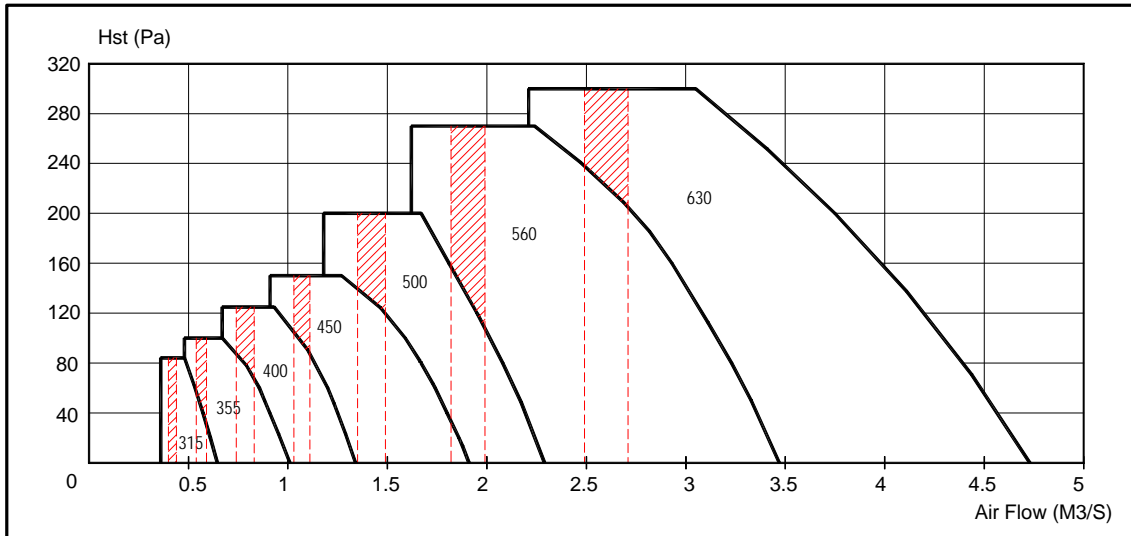

## 4 POLES - 1420 RPM

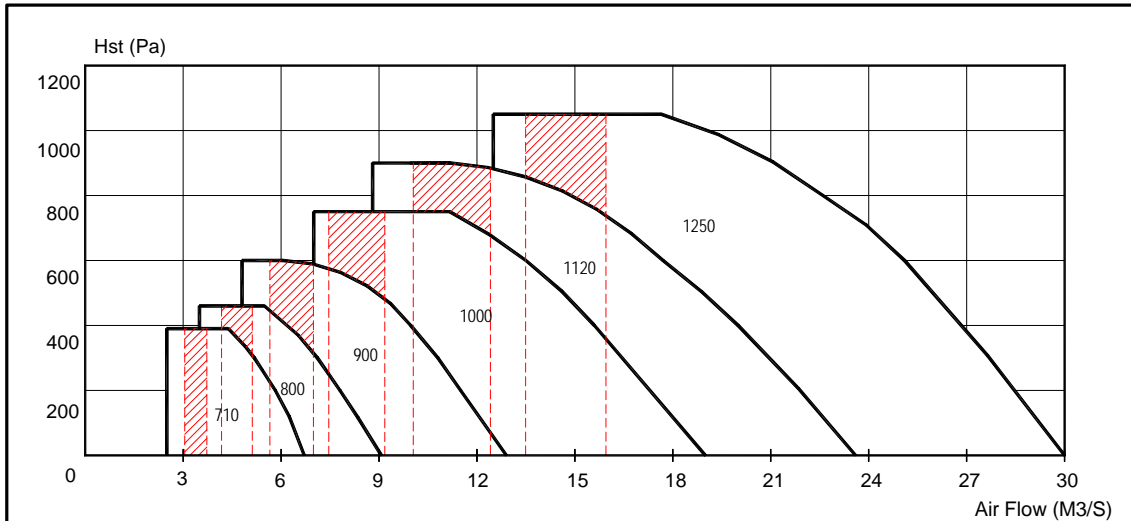

\*\*\* Shaded portion is the recommended operating range based on the duct velocity consideration (friction loss of 1 Pa/m)

## 6 POLES - 900 RPM

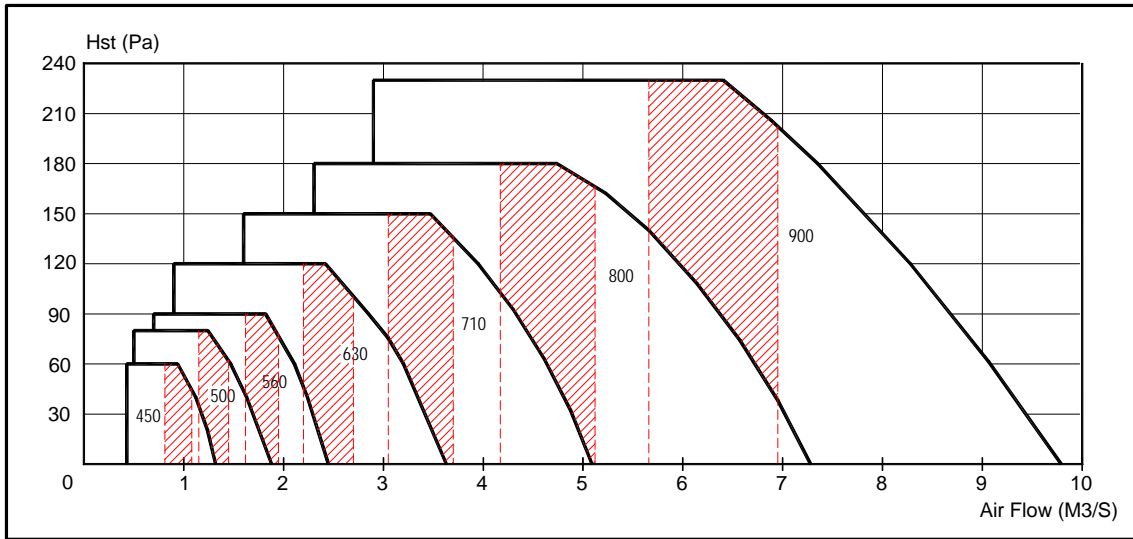

## 6 POLES - 900 RPM

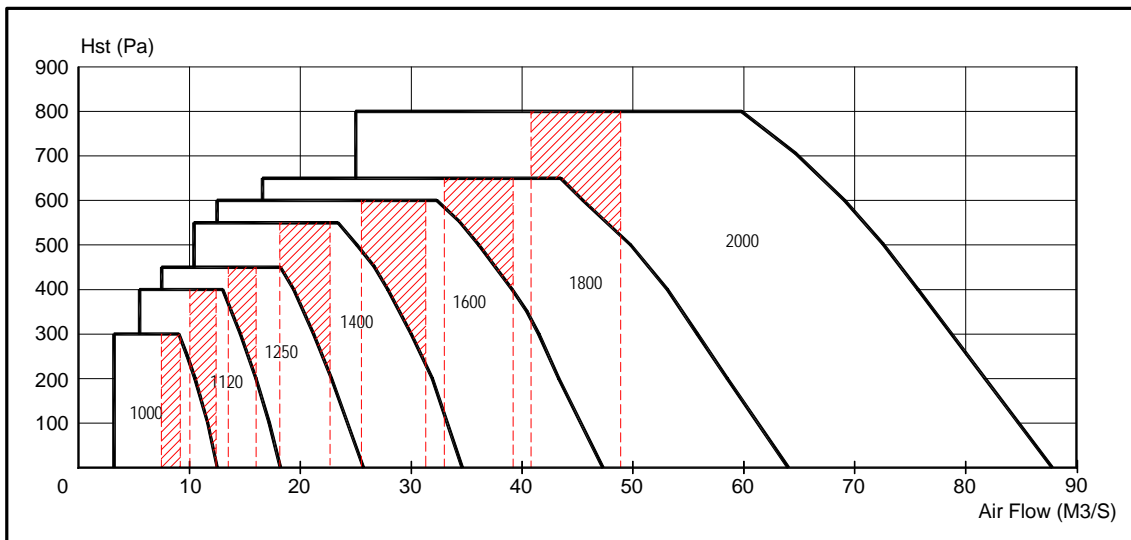

## 8 POLES - 720 RPM

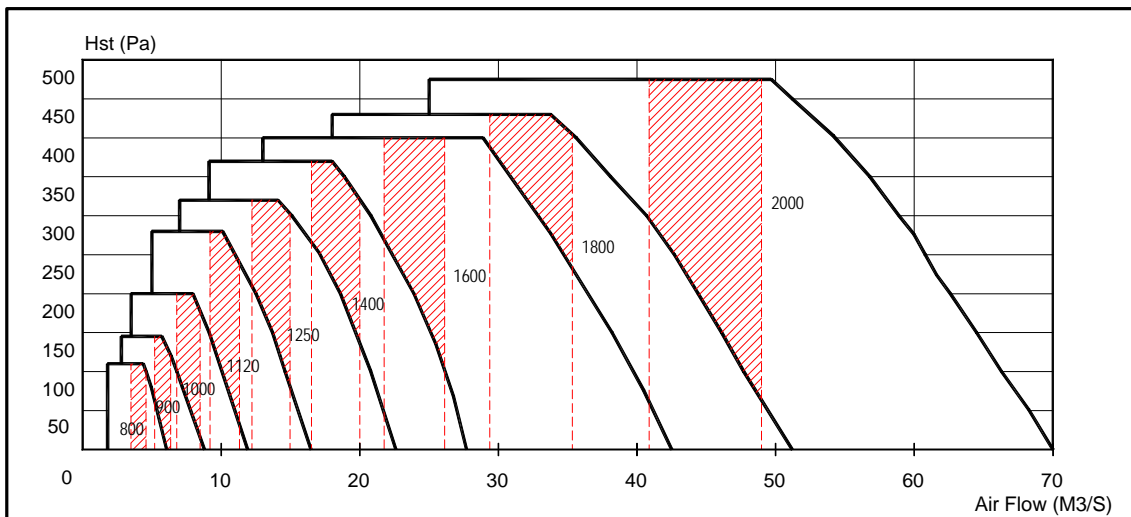

\*\*\* Shaded portion is the recommended operating range based on the duct velocity consideration (friction loss of 1 Pa/m)

## 4 POLES - 1750 RPM

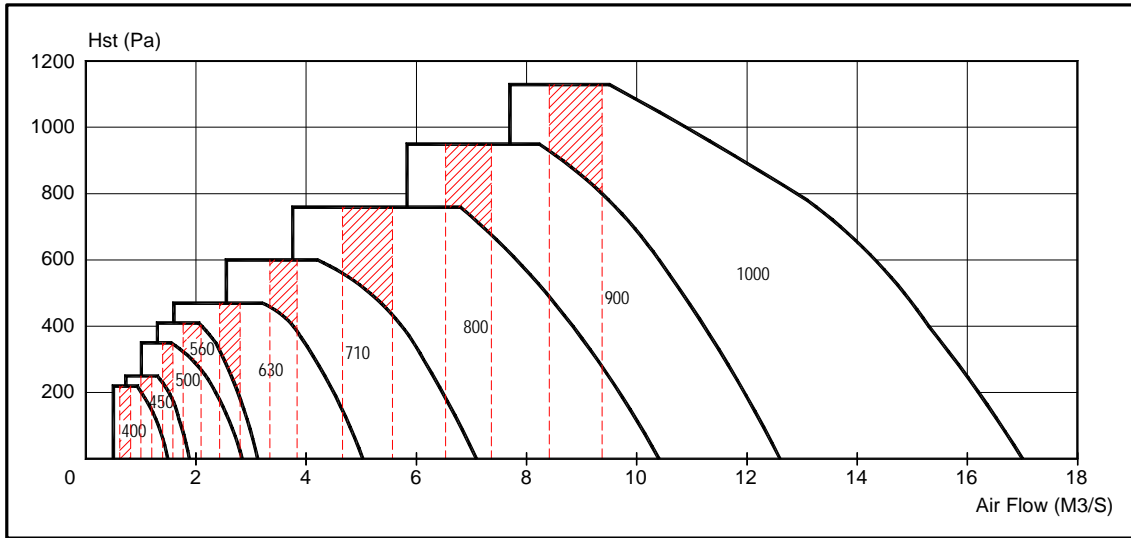

## 6 POLES - 1150 RPM

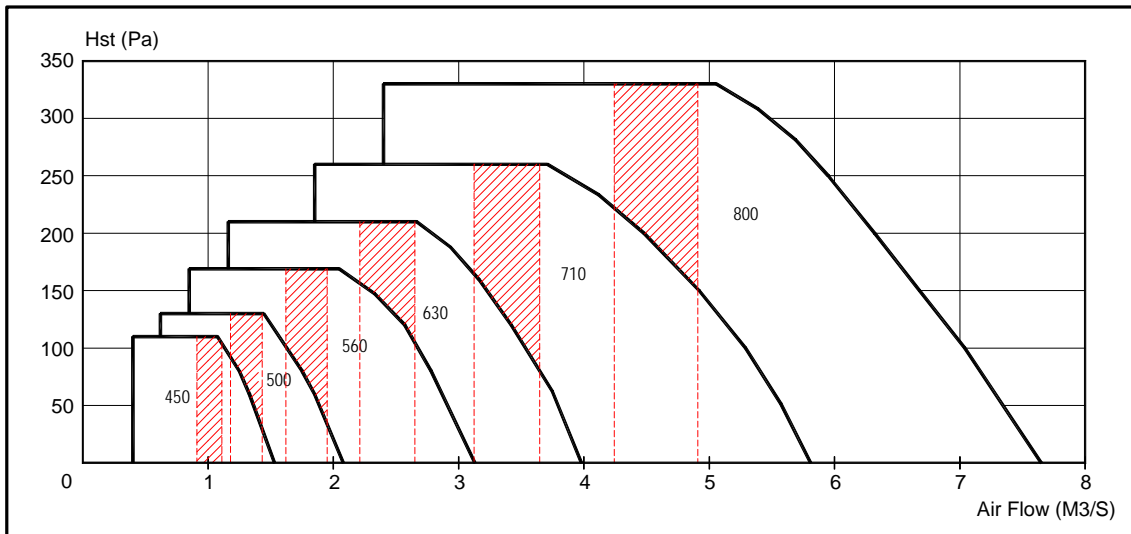

## 6 POLES - 1150 RPM

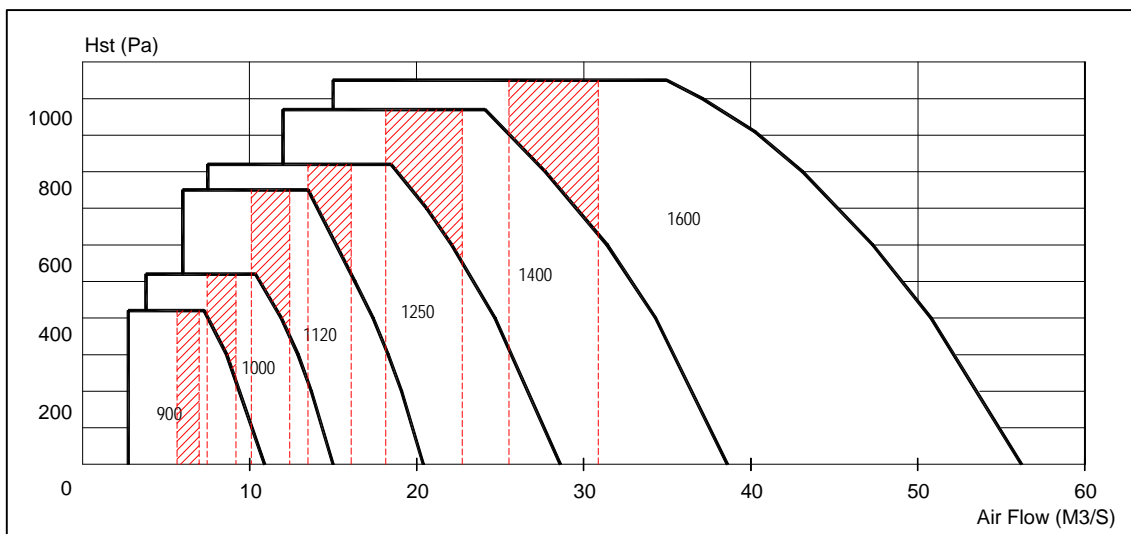

\*\*\* Shaded portion is the recommended operating range based on the duct velocity consideration (friction loss of 1 Pa/m)

# Axial fans

## Installation and Operating instructions



## Contents

<b>1</b>	<b>INTRODUCTION</b>	<b>6</b>
1.1	Purpose of this manual	6
1.2	Safety symbols used in this manual	6
1.3	Safety symbols used on fans	7
<b>2</b>	<b>GENERAL INFORMATION</b>	<b>8</b>
2.1	Definitions, basic principles, terminology used and correlated documents	8
2.2	Construction details of axial fans	8
2.2.1	Versions and motor positions	8
2.2.2	Flow indications	9
2.3	Fan name plate	10
2.4	Fan Temperature types	12
2.5	Description of fan	11
2.6	Envisaged use and foreseeable uses according to experience, and prohibited uses	17
2.7	Life cycle of fan	18
<b>3</b>	<b>WARNINGS AND MAIN SAFETY INDICATIONS</b>	<b>19</b>
3.1	Installation instructions: general information	19
3.2	Installation type A: Instructions for assembly, installation and connections	20
3.3	Installation type B: Instructions for assembly, installation and connections	20
3.4	Installation type C: Instructions for assembly, installation and connections	21
3.5	Installation type D: Instructions for assembly, installation and connections	21
3.6	Risks involved in foreseeable incorrect handling and/or abnormal uses based on experience	22
3.7	Other risks related to fans pursuant to UNI EN ISO 12499	23
3.7.1	Specific risks with fans during installation	23
3.7.2	Specific risks with fans during maintenance	24
3.7.3	Environmental risks	24
3.7.4	Vibration risks	24
3.7.5	Operating speed risks	25
3.7.6	Noise emission risks	27
3.7.7	General information on noise emission data	28
<b>4</b>	<b>TRANSPORT, MOVEMENT AND STORAGE</b>	<b>30</b>
4.1	Lifting and movement	30
4.2	General warnings for lifting separate fan parts	30
4.3	Fan lifting instructions	30

4.3.1	Lifting version 1 and 9 axial fans	30
4.3.2	Lifting version 4 axial fans	31
4.3.3	Lifting fans packed in crate	32
4.4	Storage	33
<b>5</b>	<b>INSTALLATION</b>	<b>34</b>
5.1	General information	34
5.1.1	Minimum installation distances	35
5.2	Assembly of axial fans	36
5.2.1	Version 4 axial fans	36
5.2.2	Version 1 axial fans	37
5.2.3	Version 9 axial fans	38
5.3	Mounting Configuration	39
5.4	Installing and adjusting drive belts and final checks	40
5.5	Vibration Isolator Installation	41
5.6	Blade adjustment	41
5.7	Electrical connections	42
5.8	Connection to ducts	44
<b>6</b>	<b>CHECKS TO BE MADE BEFORE AND AFTER STARTING</b>	<b>45</b>
6.1	Preliminary checks	45
6.2	Checks to be made with fan fully operating	46
6.2.1	Visual checks on protection net	46
6.2.2	Checking and cleaning parts in contact with fluids	47
6.2.3	Visual checks on impeller and casing	47
6.2.4	Dimensional checks	48
<b>7</b>	<b>AXIAL FAN OPERATING MALFUNCTIONS</b>	<b>49</b>
7.1	Most frequent malfunctions	49
<b>8</b>	<b>MAINTENANCE</b>	<b>51</b>
8.1	Bearing lubrication	52
8.2	Adjusting drive belt tension and cleaning belts	54
8.3	Checking and cleaning parts in contact with fluids	55
<b>9</b>	<b>DISMANTLING AND REASSEMBLING ESSENTIAL COMPONENTS</b>	<b>56</b>
9.1	Fan impellers with hub	56
9.2	Replacing drive belts	56
9.2.1	Assembling and dismantling pulleys	56
9.2.2	Assembling and dismantling drive belts	61



<b>10</b>	<b>FINAL DISMANTLING AND DISPOSAL OF FANS</b>	<b>63</b>
10.1	Version 4 axial fans	64
10.2	Version 1 and 9 axial fans	65
<b>11</b>	<b>TECHNICAL APPENDICES</b>	<b>66</b>
11.1	Tightening torques for nuts and bolts	66
11.2	Checklist before starting fans	68
11.3	Programmed maintenance intervals	69
<b>12</b>	<b>INDEX</b>	<b>70</b>



## Index of Diagrams

Fig. 2-1 Axial fan versions	9
Fig. 2-2 Flow indications	9
Fig. 2-3 Name plate of fan described by this manual	10
Fig. 2-4 Key to reading fan name plate	10
Fig. 2-5 TDA fan components indicated	11
Fig. 2-6 TDA-V fan components indicated	12
Fig. 2-7 TDB-II fan components indicated	13
Fig. 2-8 MXA fan components indicated	14
Fig. 2-9 TBE fan components indicated	15
Fig. 2-10 MXC fan components indicated	16
Fig. 4-1 Example of lifting version 1 and 9 axial fans	32
Fig. 4-2 Example of lifting version 4 EF axial fans	33
Fig. 4-3 Example of lifting fans packed in crate	34
Fig. 5-1 Minimum installation distances with inlet duct	36
Fig. 5-2 Minimum installation distances with free inlet	36
Fig. 5-3 Assembly of version 4 axial fans	37
Fig. 5-4 Assembly of version 1 axial fans	38
Fig. 5-5 Assembly of version 9 axial fans	39
Fig. 5-6 Vibration Isolator setup	41
Fig. 5-7 Diagram of electrical connections for single-speed and two-speed motors	43
Fig. 5-8 Example of positioning of external terminal box	43
Fig. 5-9 Assembly tolerances for flexible joints	44
Fig. 5-10 Minimum installation distances with inlet duct	44
Fig. 8-1 Checking drive belt tension	53
Fig. 9.1 Pulley holes	56
Fig. 9.2 Angular misalignment	58
Fig. 9.3 Parallel misalignment	58
Fig. 10-1 Exploded view of version 4 fan	63
Fig. 10-2 Exploded view of version 1 and 9 fan	64

## Index of Tables

Table 2-1 Types of fans	11
Table 8-1 Bearing Grease Weight Standard of TACBECON SGHT 200S (Class F)/ 600 (Class H)	52
Table 8-2 Relubrication intervals and quantity of grease according to fan rotation speed	53
Table 8-3 Setting drive belt tension: test load and deflection	54
Table 9-1 Tightening torques	60
Table 11-1 Tightening torques M for bolts with ISO metric threads	66
Table 11-2 Tightening torques for blade fixing bolts on fans with steel hub	67

# 1 INTRODUCTION



## 1.1 Purpose of this manual

This manual contains instructions and warnings, and constitutes documentation that must **compulsorily** accompany the product. Otherwise the product is lacking one of its essential safety requisites.

The manual must be kept with care, and must be made available to all persons involved with the product.

The warnings are intended to safeguard the safety of persons exposed to residual risks.

The instructions provide indications for the most appropriate conduct for the correct use of fans as intended by the manufacturer.

	<p><b>WARNING:</b></p> <p><i>The safety precautions used for the fan must also be adapted to its specific destination of use.</i></p>
	<p><i>The safety precautions differ according to the type of fan installation, as specified in paragraph 3.1 below.</i></p> <p><i>The information given in this manual is therefore indispensable for the use of fans in conformity with the destination of use of the product and without risks.</i></p>



	<p><i>In this manual the letters “KRUGER” stand for Kruger Ventilation Industries Asia Co., Ltd.</i></p>
--	--

No part of this manual may be copied, reproduced or transmitted in any form whatsoever and by any electronic, mechanical or photographic means without the express authorization of **KRUGER**.

	<p><i>The KRUGER Technical Office is fully at your disposal for all information required.</i></p>
---	---





## 1.2 Safety symbols used in this manual

Certain items of particular interest in this manual may be preceded by one of the following symbols:

	<p><b>DANGER:</b> <i>Indicates situations that might cause personal injuries.</i></p>
	<p><b>DANGER:</b> <i>Live electrical components.</i></p>
	<p><b>WARNING:</b> <i>Indicates important information of particular general interest</i></p>

### 1.3 Safety symbols used on fans

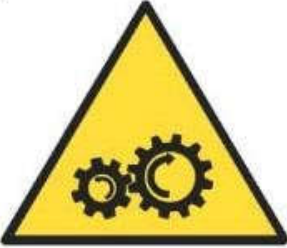
The following safety symbols are used on **KRUGER** fans:

	<p>Prohibited to lubricate and/or adjust moving parts.</p>
	<p>Prohibited to remove protection net.</p>
	<p>Hazard due to presence of moving parts. This symbol is applied near the inspection hatches provided on fans. It is permitted to open inspection hatches only when all moving parts have reached a complete standstill.</p>
	<p>Indication of a lifting point. This symbol is applied near the points identified by <b>KRUGER</b> for lifting and moving the fan.</p>
	<p>Hot surfaces &gt;60 °C. Danger of burns or scalding. Hot surfaces – Emission of hot fluids. This symbol is applied if the fan is used to move hot fluids.</p>

## 2 GENERAL INFORMATION

### 2.1 Definitions, basic principles, terminology used and correlated documents

- Point 3.1 of the UNI EN ISO 13349 standard defines a fan as “rotary-bladed machine which receives mechanical energy and utilizes it by means of one or more impellers fitted with blades to maintain a continuous flow of air or other gas passing through it and whose work per unit mass does not normally exceed 25 kJ/kg.”
- Point 3.6.1 of the UNI EN ISO 13349 standard defines an axial-flow fan as “a fan in which the air enters and leaves the impeller along essentially cylindrical surfaces with the fan.”
- The blades may have the following shapes: flat (obtained directly by pressing sheet steel) or more frequently a wing profile (obtained with aluminium).

The fundamental dimensions that define a fan are as follows:

- Volumetric flow: this is the volume of fluid passing through the fan in a certain period of time - one second ( $\text{m}^3/\text{s}$ ), one minute ( $\text{m}^3/\text{min}$ ) or one hour ( $\text{m}^3/\text{h}$ );
- Static pressure: this is the energy imparted by the impeller to overcome the resistance offered by the system to the passage of fluid (measured in mm of water column = mm w.c. or Pascal = Pa);
- Dynamic pressure: this is the energy possessed by the fluid as a result of the speed imparted by the impeller at the output opening of the fan (measured in mm w.c. or Pa);
- Total pressure: this is the arithmetical total of static pressure and dynamic pressure (measured in mm w.c. or Pa);
- Flow: two directions for the fluid moved are identified for an axial fan, either from the motor towards the impeller (flow A) or from the impeller towards the motor (flow B), see Fig. 2-2;
- Rotation speed: this is the rotation speed of the impeller, and is measured in revolutions per minute (RPM);
- Efficiency: this is the percentage ratio between the energy that the fan manages to transmit to the fluid and the energy supplied by the motor to the impeller; it depends on impeller characteristics, and has no measurement units;
- Power absorbed: this is the power needed (provided by the motor) by the fan for correct operation, and is measured in kW;
- Name plate motor power: this is the nominal power that the motor can provide; it must always be greater than the power absorbed by the fan, and is measured in kW;
- Sound pressure level: this is the energy propagated into the channel of the external ear and that generates vibrations of the ear drum, namely the level of noise emitted by the fan; it is measured in decibels using scale A (a scale that allows the impact of noise on the human ear to be assessed, according to the frequency of the noise);
- Sound power: this is the index of emission of sound power, and constitutes an intrinsic and constant characteristic of a sound source; it is expressed in watts.

The following documents are correlated to this manual:

- Kruger fan selection sheet for the fan, which lists dimensions, weights, rotation speeds, fluid types and data on flexible couplings and vibration dampeners.
- Kruger Product Traveller and Finished Goods Card, which indicates the characteristics of the transmission installed on the fan.
- The instruction and warnings manual of the manufacturer of the electric motor (if supplied together with the fan).

## 2.2 Construction details of axial fans

### 2.2.1 Versions and motor position

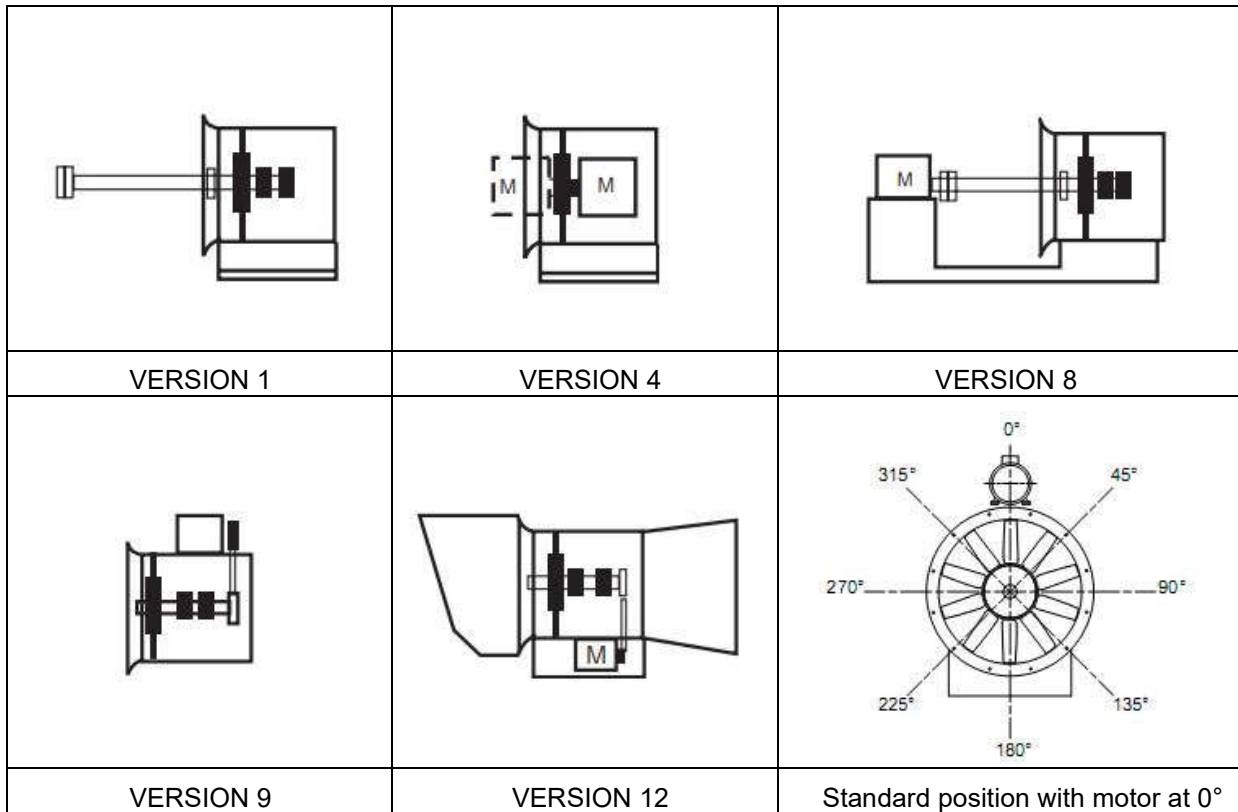

Fig. 2-1 Axial fan versions

### 2.2.2 Flow indications

The diagram refers to version 4, but is valid for all construction versions:

A = Flow from motor to impeller

B = Flow from impeller to motor

U = Flow upwards

D = Flow downwards

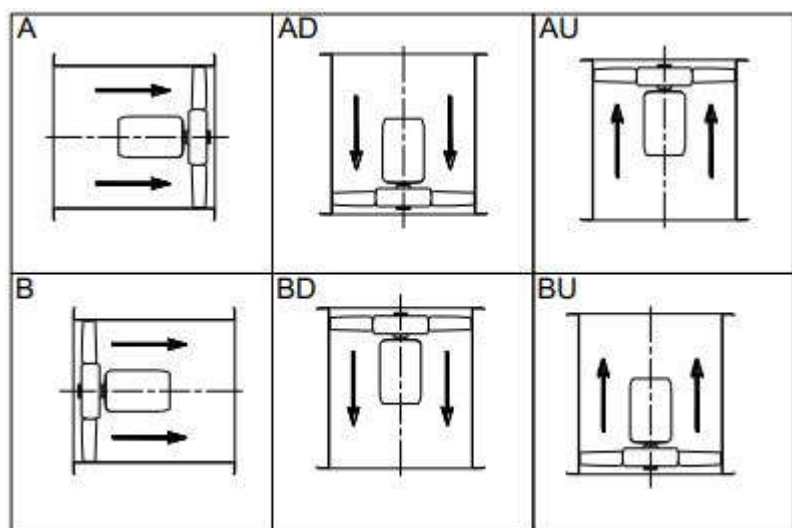

Fig. 2-2 Flow indications

### 2.3 Fan name plate

The name plate is the only means of fan identification recognized by the manufacturer. It must not be modified, and must not be removed or damaged. Fig. 2-3 shows the plate fitted to the fan.



Fig. 2-3 Name plate of fan described by this manual

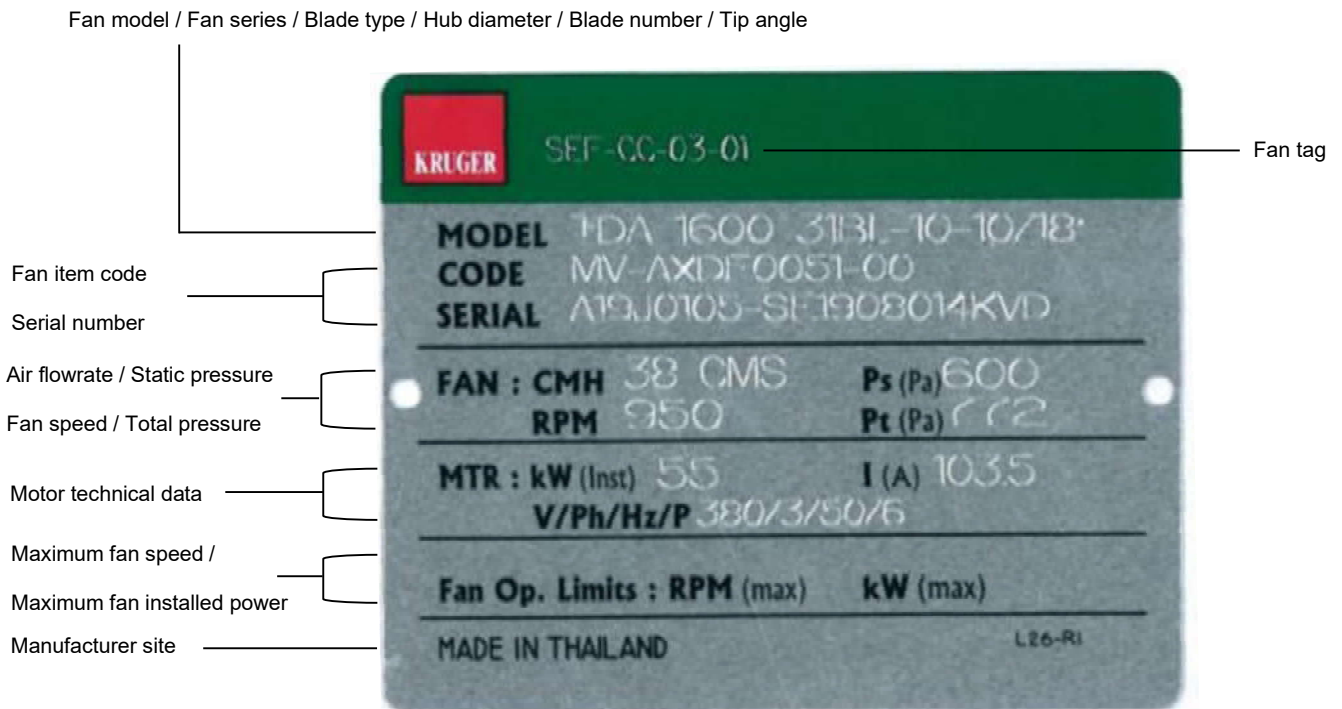

Fig. 2-4 Key to reading fan name plate

## 2.4 Fan Temperature types

Fan Series	Range (mm)	General Ventilation 20°C to +55°C	F <sub>r</sub> 250 250°C / 2 hrs	F300 300°C / 1 hr	F <sub>r</sub> 300 300°C / 2 hrs	F400 400°C / 2 hrs
TDA	315-2000	x	x	x	x	x
TDA-V	315-2000	x	x	x	x	x
TDC	450-2000	x	x	x	x	
TDD	450-2000	x	x	x	x	x
TDB-II	315-1400	x	-	-	-	-
TBE	315-2000	x	-	-	-	-
MXA	450-2000	x	x	x	x	x
TRC	1250-2240	x	x	x	x	x
MXC*	315-2000	x	x	x	x	x

Please consult KRUGER for fan series other than specified.

\* MXC series is designed for kitchen exhaust application and comply with UL 762

Table 2-1 Types of fans

## 2.5 Description of fan

### 2.5.1 TDA series

Taking the fan shown in Fig. 2-5, TDA fan is generally constituted by the following components:

- Protection Net (1);
- Impeller (2);
- Motor Support (3);
- Motor (4);
- Tube Casing (5);
- View Port (6);
- Motor Base Reinforce (7);
- Motor Base (8);
- Mounting Feet (9);
- Hanger (10);
- Terminal Box (11)

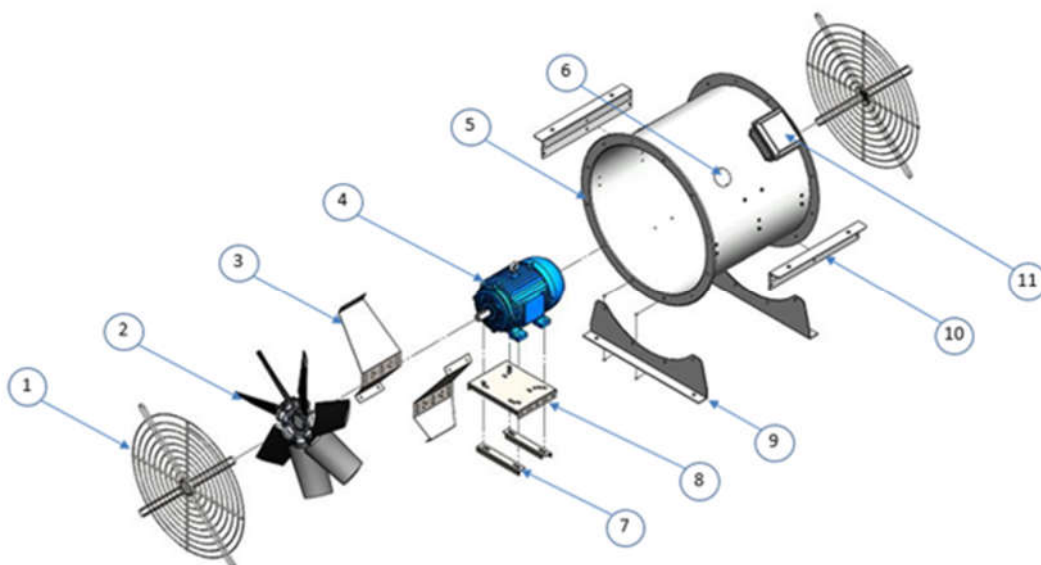

Fig. 2-5 TDA fan components indicated

### 2.5.2 TDA-V series

Taking the fan shown in Fig. 2-6, TDA-V fan is generally constituted by the following components:

- Protection Net (1);
- Impeller (2);
- Motor (3);
- Tube Casing (4);
- View Port (5);
- Motor cover (6);
- Terminal Box (7);
- Terminal Support (8);
- Outlet Vane (9);
- Hanger (10);
- Mounting Feet (11);
- Motor Base (12)

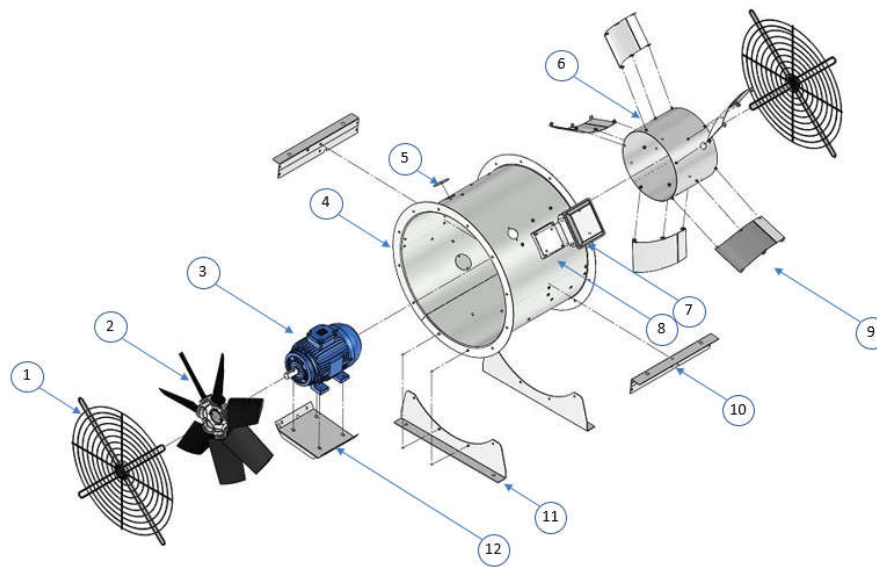

Fig. 2-6 TDA-V fan components indicated



### 2.5.3 TDB-II series

Taking the fan shown in Fig. 2-7, TDB-II fan is generally constituted by the following components:

- Protection Net (1);
- Motor cover Plate (Rear) (2);
- Motor cover Rong 1 (3);
- Motor Support (4);
- Motor Base (5);
- Mounting Feet (6);
- Hanger Bar (7);
- Tube Casing (8);
- Motor cover Plate (Front) (9);
- Hub (10);
- Impeller (11);
- View Port (12);
- Terminal Box (13);
- Motor (14);
- Motor cover (15)

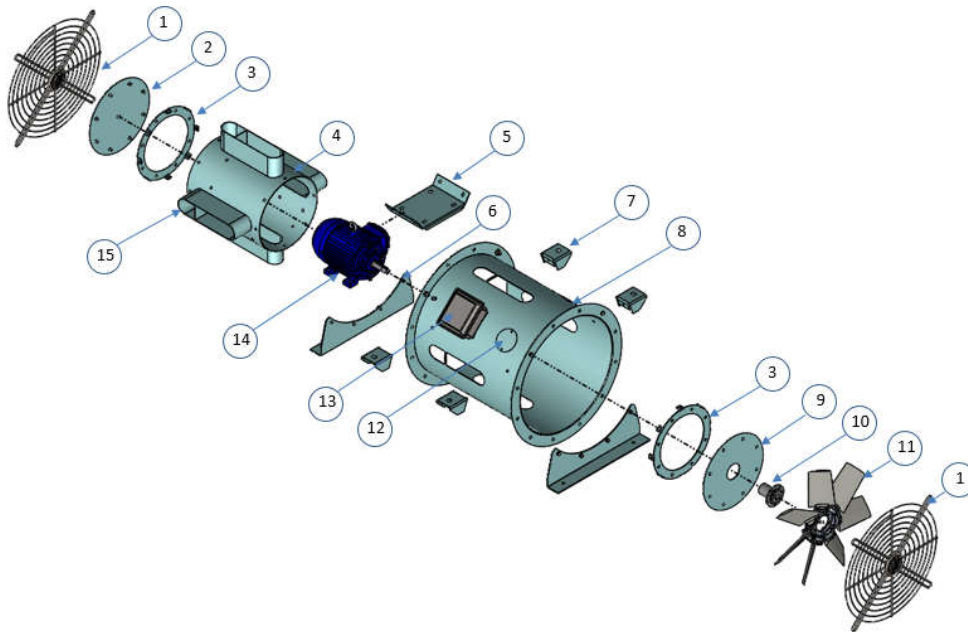

Fig. 2-7 TDB-II fan components indicated

### 2.5.4 MXA series

Taking the fan shown in Fig. 2-8, MXA fan is generally constituted by the following components:

- Pod Cover (1);
- Impeller (2);
- Hub (3);
- Tube casing (4);
- View Port (5);
- Terminal Box (6);
- Motor (7);
- Motor cover (8);
- Outlet Vane (9);
- Motor Base (10);
- Terminal Box (11);
- Hanger (12);
- Mounting Feet (13)

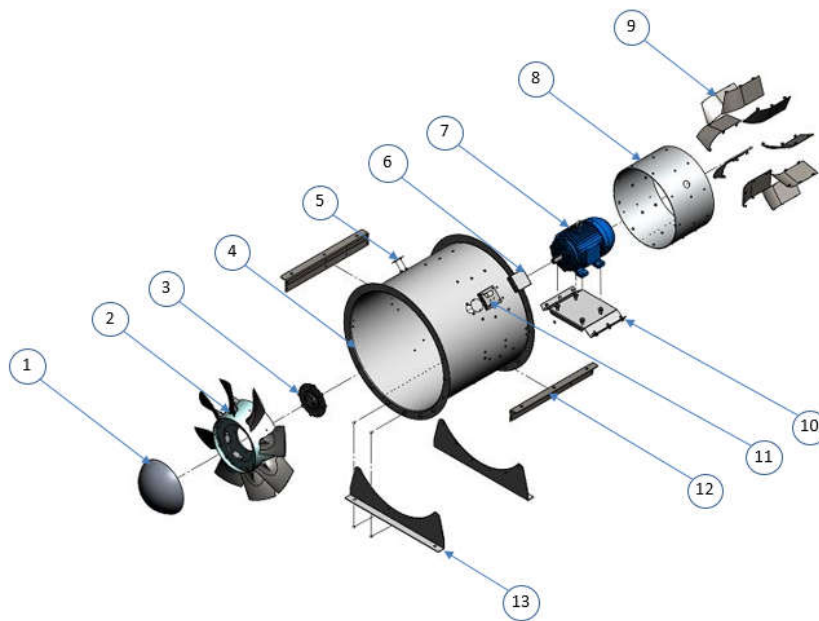

Fig. 2-8 MXA fan components indicated

### 2.5.5 TBE series

Taking the fan shown in Fig. 2-9, TBE fan is generally constituted by the following components:

- Protection Net (1);
- Upper Belt Back Cover (2);
- Upper Belt Casing (3);
- Upper Belt Front Cover (4);
- Motor (5);
- Motor Base (6);
- Lip Channel (7);
- Hanger Bar (8);
- Bearing Support (9);
- Bearing (10);
- Shaft (11);
- Hub (12);
- Impeller (13);
- Bearing Base (14);
- Mounting Feet (15);
- Drive Set (16);
- Lower Belt Back Cover (17);
- Lower Belt Casing (18);
- Lower Belt Front Cover (19);
- Access Door (20)

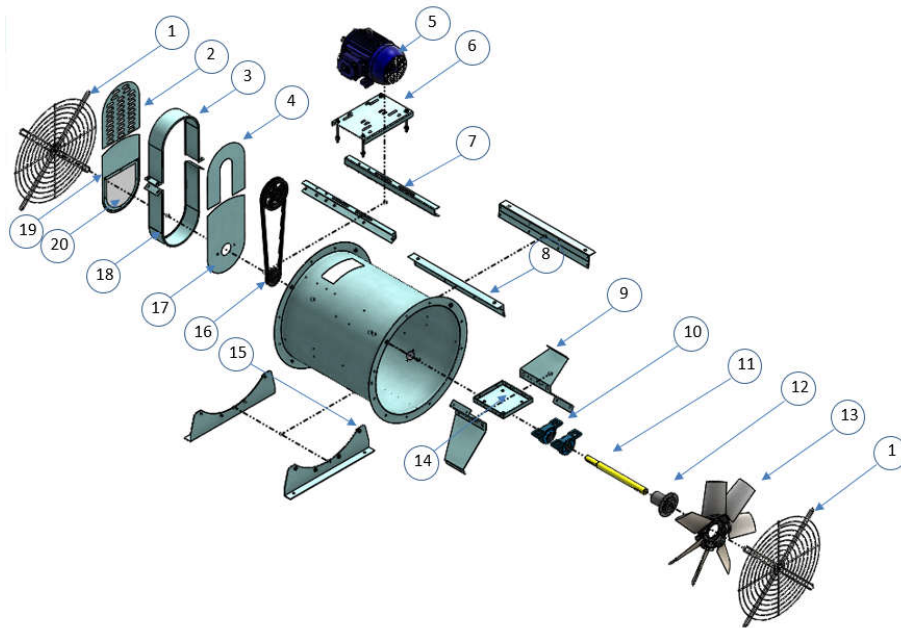

Fig. 2-9 TBE fan components indicated

### 2.5.6 MXC series

Taking the fan shown in Fig. 2-10, MXC fan is generally constituted by the following components:

- Protection Net (1);
- Inlet Cone (2);
- Wheel (3);
- Outlet Vane (4);
- Tube Casing (5);
- Hanger Bar (6);
- Mounting Feet (7);
- Motor Base (8);
- Motor (9);
- Bearing Base (10);
- Bearing (11);
- Shaft (12);
- Drive Set (13);
- Belt Cover (14);

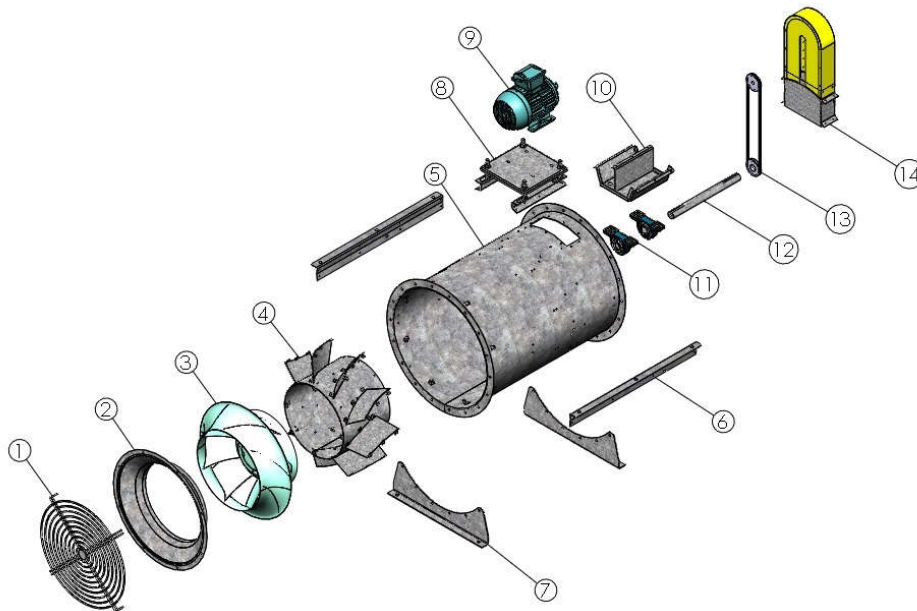

Fig. 2-10 MXC fan components indicated

## 2.6 Envisaged use and foreseeable uses according to experience, and prohibited uses

The envisaged use for the fan with the name plate as shown in Fig. 2-3 is as follows:

A commercial axial fan is a machine that serves to move a gaseous fluid inside a fluid movement system to which the fan is connected by means of ducts and technical chambers provided for this purpose. The flow of the fluid moved by the machine enters and leaves the fan in an axial direction.

The energy required to move the volumes of fluid entering the system from the suction inlet is transferred by the rotation of the impeller inside the casing. Impeller rotation is obtained in most cases by the energy supplied by an electric motor, as indicated earlier in paragraph 2.4 of this manual.

The fan must be used in the flow range specified in the performance diagrams. Use of the fan with flows lower than the minimum value indicated in the diagrams may cause unstable fluid dynamic operation and vibrations.

Axial fans are used in many applications associated prevalently with the development of industrial processes. Here is a list of some possible industrial sectors with application examples:

- Textile sector (air conditioning and treatment, drying)
- Food processing sector (drying, cooking, circulation)
- Steel sector (extraction of fumes)
- Painting sector (filtration, dust removal)
- Transport sector such as maritime and railways (conditioning, motor cooling)
- Other applications not listed but agreed with our Engineering and/or Research & Development Area.

Some categories of use other than those described above are excluded, and more specifically:

- Operation of the fan with non-gaseous fluids or with fluids with characteristics different from those defined in the technical information sheet accompanying the fan, since structural damage may be caused to the fan with the possible risk of injury to persons and/or damage to things;
- Operation of the fan in all types of system with pressures (present or even partially generated by the fan) greater than 1.05 times standard atmospheric pressure, since structural damage may be caused to the fan with the possible risk of injury to persons and/or damage to things;
- Operation of the fan in all types of system classified in accordance with the ATEX 2014/34/EC Directive and that move potentially explosive fluids, since risks of ignition/explosion may occur with possible injury to persons and/or damage to things. Fans that are specifically constructed, classified and marked for ATEX conformity for a suitable category for the installation location are excluded, and these must be accompanied by the legally required documentation;
- Operation of the fan in industrial chemical plants where the fluid moved is highly corrosive for the materials used in fan construction, or in the presence of highly toxic fluids where the construction methods of casings and the types of seal used are not suitable for this specific application, since structural damage may be caused to the fan with the possible risk of injury to persons and/or damage to things;
- Operation of the fan in mining industry plants and with underground installations, since additional risks not considered in the use of the fan above ground may arise, with possible injury to persons and/or damage to things.

## 2.7 Life cycle of fan

The reliability of all components is guaranteed by a production process with ISO 9001 certification and by compliance with the programmed maintenance intervals indicated in paragraph 11.3 of this manual.

The components normally subject to wear are the following:

- bearings, calculated for a theoretical duration normally of 40,000 hours
- drive belts, calculated for a theoretical duration of 25,000 hours

For safety reasons, protection net in electro welded wire must be replaced every 2–3 years.

In the hypothesis of use of the fan at constant speed for two work shifts every day equivalent to 16 hours, calculated for 250 days per year, the expected life cycle for the impeller is equivalent to 40,000 hours.

In case of use in conditions of particularly difficult operation (medium, high), this limit must be reduced. Any such reduction must be assessed in collaboration with the **KRUGER** Technical Office. In the specific case of operation at variable speeds, the impeller life cycle must be assessed on a case-by-case basis, and must also be agreed with the **KRUGER** Technical Office.

	<p><b>CAUTION:</b></p> <ul style="list-style-type: none"><li>• <i>Do not exceed the maximum rotation speed indicated by KRUGER.</i></li><li>• <i>Do not use ON-OFF operating cycles unless expressly approved by KRUGER.</i></li><li>• <i>Do not use variable-speed cycles unless expressly approved by KRUGER.</i></li><li>• <i>Do not subject the fan to thermal gradients greater than 3°C/minute.</i></li></ul>
--	---

Even if it has never operated, an impeller that has been stored for more than ten years must be checked by **KRUGER** for possible defects before it can be used.

### 3 WARNINGS AND MAIN SAFETY INDICATIONS

#### 3.1 Installation instructions: general information

	<p><b>Fans can be installed in four different ways, in conformity with the AMCA 201 standard:</b></p> <ul style="list-style-type: none"> <li>• <b>Type A: Free Inlet, Free Outlet;</b></li> <li>• <b>Type B: Free Inlet, Ducted Outlet;</b></li> <li>• <b>Type C: Ducted Inlet, Free Outlet;</b></li> <li>• <b>Type D: Ducted Inlet, Ducted Outlet.</b></li> </ul>
---	--

Generally, KRUGER does not and cannot know which of the above installation types will be chosen and applied by the user, and unless otherwise specified by contract, the fan is supplied for installation types B, C or D according to the fan series and flow. The person responsible for designing the system, together with the final user, must conduct an analysis of risks for the specific installation type chosen.

Depending on the way that it is intended to install and insert the fan in the fluid movement system, the following protection net must be installed, according to installation type:

- Type A installation: fixed **KRUGER** protection net installed on inlet and outlet;
- Type B installation: fixed **KRUGER** protection net installed only on inlet;
- Type C installation: fixed **KRUGER** protection net installed only on outlet;
- Type D installation: no fixed protection net installed on inlet and outlet.

The system designer and the user must ensure that ducting systems are fitted with conformant protection net for the duct connections made, as follows:

- Type A installation: no protection net (no ducts are connected);
- Type B installation: fixed protection net fitted on outlet duct;
- Type C installation: fixed protection net fitted on inlet duct;
- Type D installation: fixed protection net fitted both on inlet and outlet ducts.

	<p><b>CAUTION:</b></p> <p><i>Unless otherwise specified by contract, fans are supplied for installation types B, C or D in conformity with the AMCA 201 standard and according to fan series and flow.</i></p> <p><i>Always verify all safety aspects of the installation type chosen.</i></p>
---	--

With regard to protection net to be fitted to ducts, in compliance with the design project, they must prevent access to parts of the fan and its accessories that could cause injuries. They must also be sufficiently robustly constructed to resist the stresses generated by the machine and environmental conditions.

**KRUGER** invites users and/or system designers to design, construct and install protection net in conformity with the criteria of the UNI EN ISO 12499 standard.

	<p><b>CAUTION:</b></p> <p><i>Even with protection net installed (regardless of the conditions of supply or installation), the fan may be dangerous due to the effects of indrawn or moved air.</i></p> <p><i>Depending on the dimensions of the fan, this type of danger may even <b>CAUSE DEATH</b>.</i></p> <p><i>The risk of being crushed against the inlet grille may be fatal or may cause serious injuries (crushing of body parts, unconsciousness).</i></p>
---	--

	<p><b>CAUTION:</b></p> <p><i>It is advisable to adopt precautions that prevent access to the room containing the fan while it is operating, or to keep persons away with fixed protection net that maintain a safe distance from the inlet opening.</i></p>
---	---

	<p><b>WARNING:</b></p> <p><i>Check the efficiency of all protection net every month. In case of wear, damage or breakage, replace them immediately.</i></p>
---	---

Protection net must be fixed securely in position using fixings that are not slackened by vibrations, and that require the use of a tool for their removal.

	<p><b>CAUTION:</b></p> <p><i>On starting and in compliance with programmed maintenance intervals, check that nuts and bolts are correctly tightened. Monitor vibration levels with a vibrometer, and establish an alarm threshold (see paragraph 12.3).</i></p>
---	---

It is always the responsibility of the installer to guarantee that there is an adequate level of protection against the risk of accidental contact with moving parts.

The installer and the user must also take other types of risk into consideration, and in particular those deriving from the entry of foreign bodies and the inlet of explosive, inflammable or toxic gases or gases at a high temperature.

The risks involved in maintenance operations must also be taken into consideration. It must be possible to perform these operations in conditions of maximum safety, by isolating the fan from the motor or by taking other suitable precautions.

	<p><b>CAUTION:</b></p> <p><i>A safety procedure for access to the fan must be compiled, taking into consideration the indications provided by the manufacturer, information deriving from the analysis of risks at the installation point and safety requirements in workplaces.</i></p>
---	--

### 3.2 Installation type A: Instructions for assembly, installation and connections

In case of type A installations, since neither the inlet nor outlet of the fan are connected to ducts, protection net must be fitted on both the inlet and the outlet.

Protection net dimensions can be obtained from the dimensional drawing given in catalogues, from scale and non- scale drawing programs downloadable from the reserved area of the website, or from any dimensional drawings provided as documentation together with the products supplied.

### 3.3 Installation type B: Instructions for assembly, installation and connections

In case of type B installations, since the fan inlet is free and the outlet is connected to a duct, a protection net must be fitted on the inlet.

Protection net dimensions can be obtained from the dimensional drawings given in catalogues, from scale and non- scale drawing programs downloadable from the reserved area of the website, or from any dimensional drawings provided as documentation together with the products supplied.



### 3.4 Installation type C: Instructions for assembly, installation and connections

In case of type C installations, since the fan inlet is connected to a duct and the outlet is free, a protection net must be fitted on the outlet.

Protection net dimensions can be obtained from the dimensional drawings given in catalogues, from scale and non- scale drawing programs downloadable from the reserved area of the website, or from any dimensional drawings provided as documentation together with the products supplied.

	<p><b>CAUTION:</b></p> <p><i>Protection net are designed to protect against accidental contacts and to resist the pressures generated only by the fan to which they are fitted.</i></p> <p><i>Each protection net, if supplied individually, can be used only on the fan for which it was designed. If therefore a protection net is ordered individually, it is compulsory to provide the reference details of the fan to which it will be fitted (serial number).</i></p>
---	---

### 3.5 Installation type D: Instructions for assembly, installation and connections

In case of type D installations, since both the fan inlet and outlet are connected to ducts, no protection net need to be installed on either the inlet or outlet of the fan.

	<p><b>CAUTION:</b></p> <p><i>The system designer must assess the need to fit any necessary protection net at the inlet and outlet ends of the system.</i></p>
--	---

	<p><i>For installation types B, C and D, it is advisable to insert flexible duct between the fan and ducts so as to compensate for any misalignments that may be present, to prevent the transmission of vibrations and to avoid structural stress.</i></p>
---	---

The choice of a standard flexible duct for applications that are not particularly difficult depends on two fundamental factors:

- dust content of the fluid moved
- fluid temperature

	<p><b>CAUTION:</b></p> <p><i>Flexible ducts are suitable for installation on a single-stage fan, and must not be subjected to effects of fluid dynamics caused by other machines installed in the same fluid movement system.</i></p>
---	---

For special applications, such as for example the movement of fluids at a high temperature or that are particularly corrosive, or to guarantee perfect sealing of the joint, special joints must be used.



In this case the user and/or system designer must contact the **KRUGER** Technical Office.

### 3.6 Risks involved in foreseeable incorrect handling and/or abnormal uses based on experience

- When moving, lifting and installing the fan, always follow the instructions provided in this manual.
- It is absolutely prohibited to use the fan in conditions other than those indicated by the data on the name plate.
- It is absolutely prohibited to deactivate, remove, modify or in any other way render inoperative safety devices, protection net or control devices, either of individual components or of the fan itself.
- Do not position the hands, arms or any other part of the body near moving parts, even by forcing the opening of apertures.
- It is forbidden to extend parts of the body beyond protection structures. It is forbidden to use aids that may increase normal accessibility.
- It is forbidden to use fans in atmospheres or environments with the risk of explosions, with the exception of fans that are in conformity with the ATEX 2014/34/EC Directive.
- It is forbidden for unauthorized operators to work on any fan defects or malfunctions or to alter the type of operation or installation.
- Great care must be taken to ensure that fluids with characteristics other than those defined in this manual (technical information sheet) are not introduced into fans.
- After all repair work involving the removals of protection net, barriers or other protection devices, these must be replaced and checked for correct positioning and efficiency before the fan is started again.
- All protection net and safety devices must be maintained in conditions of perfect and constant efficiency. Warning signs, safety symbols and danger warnings must be also maintained in perfect efficiency and in their correct position.
- When tracing the causes of any faults or malfunctions with fans, take all the precautions described in this manual, intended to prevent all and any kind of injury to persons or damage to things.
- Remember to tighten all bolts, nuts and fixing rings on all mechanical components that are adjusted or serviced, following the indications given in Table.
- Before starting the fan, check that all protection net and safety devices are installed and in perfect operating condition. If they are not, it is absolutely prohibited to start the fan. The person responsible for plant safety or the department head must be informed immediately.
- Operators must be provided with Personal Protection Equipment (PPE) in conformity with legal requirements. Bulky garments and various accessories (ties, wide sleeves, etc.) are prohibited.

**3.7** The fluid moved by the fan must be adequately checked for the possible presence of toxic and/or inflammable substances, even if their presence is not envisaged in the use of the fan. Other risks related to fans pursuant to UNI EN ISO 12499

The specific risks defined below are those deriving from mechanical aspects of the fan.



	<p><b>A person may be injured as a result of:</b></p> <p>a) <i>being dragged between a moving part and a fixed part, for example an impeller and the casing or some other fixed part of the fan;</i></p> <p>b) <i>being dragged between two moving parts, for example a drive belt and a pulley;</i></p> <p>c) <i>being dragged into the fan through the air inlet, with consequent contact with the shaft or impeller;</i></p> <p>d) <i>contact with a moving part, such as the impeller;</i></p> <p>e) <i>ejection from the fan outlet of fragments deriving from the introduction of residual solids or liquids extraneous to the process, or deriving from the suction environment;</i></p> <p>f) <i>an object drawn into the fan mouth and ejected at high speed from the fan inlet or outlet;</i></p> <p>g) <i>structural defects of fan components;</i></p>
	<p>h) <i>contact with fan surfaces at dangerous temperatures, for example below -20°C or higher than +50°C;</i></p>
	<p>i) <i>when working with hot fluids, there may be losses of jets of hot fluid from the transmission shaft hole that may cause burns or scalds.</i></p> <p>l) <i>the potential harmfulness of the fluid being moved or the presence of substances that in case of leaks may be hazardous;</i></p> <p>m) <i>a hazard deriving from motor overspeed, which may cause the breakage of machine parts;</i></p> <p>n) <i>the inlet of air at abnormal temperatures higher than those recommended may cause structural deformations, malfunctions and hazards.</i></p>

**3.7.1 Specific risks with fans during installation**

- The user must provide a well-levelled fixing surface. Incorrect levelling may cause abnormal fan vibrations that over time could cause deformation and/or breakage, with the detachment of fan parts, representing a hazard for exposed persons that may even be fatal.
- The user must also arrange electrical connections for the fan casing or structure to the main electrical grounding system of the place of use, to prevent any formation and accumulation of static electricity.
- All protection net installed must remain correctly connected to the fan with all relative fasteners (bolts, nuts, etc.). The removal of one or more fixing points may impair the functionality and solid fixing of the protection net.
- Fans supplied as standard versions **are not** intended for use in potentially explosive environments.
- The place of installation of the fan must be kept clean. Any spills of oil or water not due to the fan must be cleaned away as quickly as possible.
- The minimum installation distances defined in this manual must always be respected to guarantee correct operation and the absence of additional risks. Incorrect positioning could impair the correct operation of the fan.

### 3.7.2 Specific risks with fans during maintenance

- During maintenance and cleaning operations on the impeller, take great care with rotations of the impeller, which could cause trapping or cutting injuries against fixed parts of the casing.
- A programmed maintenance schedule for the fan must be prepared and applied, so as to prevent mechanical failures or breakages caused by wear or inadequate maintenance (see paragraph 12.3).

	<p><b>CAUTION: IT IS ABSOLUTELY PROHIBITED TO:</b></p> <ul style="list-style-type: none"> <li>• <i>Carry out any type of maintenance operation without having first checked that the fan impeller is effectively at a standstill.</i></li> <li>• <i>Proceed with any type of maintenance operation on the fan (including lubrication) without having first disconnected it from the mains powers supply.</i></li> <li>• <i>Clean the fan while it is operating.</i></li> <li>• <i>Open fan protection net or inspection hatches while it is operating.</i></li> </ul>
	<p><b>CAUTION:</b></p> <p><i>Even when the power supply to a fan is interrupted, its rotating parts may still move, due to air passing through the fan, either naturally or from fluid currents generated by a fan located in other parts of the system of linked ducts, or due to the inertia of the impeller after the machine has been switched off. In this case as well, there may be the risk of trapping or cutting injuries against fixed parts of the casing.</i></p>

### 3.7.3 Environmental risks

**KRUGER** fans are designed to operate in and to withstand ordinary conditions of working environments. The presence of:

- Vibrations
- Corrosive agents (dust, gas, fumes, mist)
- High temperatures
- Condensation
- Solid bodies
- Abnormal turbulence
- Currents of air
- Voltage differences due to installation

can affect the lifespan of components, causing premature deterioration, above all with respect to protection net.

Since it is impossible to establish all-inclusive criteria that can take into account all the possible combinations of these effects, it is advisable to implement a plan of periodical checks according to the effective deterioration noted, so that any variations in structural characteristics can be detected in subsequent checks.

### 3.7.4 Vibration risks

Vibrations are the main factor affecting the operational life and safety of fans, and for this reason it is essential to accurately monitor their level during fan operation and work cycles.

The ISO 1940/1 and ISO 2372 international standards establish the field of acceptability and the classification of rotating machines, and more specifically, the ISO 14694 standard establishes values for commercial fans.

The reference values for **KRUGER** products are established by category BV4 of AMCA 204 standard.

If ignored, vibrations can:

- Cause the formation of cracks serious enough to cause structural failure, which may even be sudden
- Cause difficult operating conditions for bearings, with malfunctions that may even include seizing (with dangerous overheating effects)
- Cause slackening of tightening and fixing components (nuts and bolts)
- Generate greater noise.

**KRUGER** strongly recommends the use of a control and monitoring system for the fan, with continuous monitoring of vibrations and bearing temperatures.

Depending on the specific application and use of the fan, it is advisable to define an "alarm threshold" for fan vibration levels and bearing operating temperatures.



*The monitoring of vibrations and temperatures makes it easier to take preventive actions against accidents.*

### 3.7.5 Operating speed risks

Operating speeds greater than those envisaged by the fan design can create conditions of risk due to the reduction of the operative lifespan of moving parts.

In case of faults or malfunctions, overspeed conditions may be created due to:

- Errors in the control system
- Short circuits on monitoring components
- Driver or inverter malfunctions
- Mechanical breakage of components, and in particular on shafts.



**CAUTION:**

- *Do not exceed the maximum rotation speed indicated by KRUGER.*
- *Do not use ON-OFF operating cycles unless expressly approved by KRUGER.*
- *Do not use variable-speed cycles unless expressly approved by KRUGER.*
- *Do not subject the fan to thermal gradients greater than 3°C/minute.*



**CAUTION:**

*A condition of overspeed, even for a limited time, may cause irreversible damage and create situations of extreme risk hazards.*

During normal operation, conditions of overspeed attributable to the drive system or motor may occur, in particular if the fan is supplied "with shaft only" or with motor "without drive system".

In these cases, it is the responsibility of the user to verify and guarantee the correctness of additional installations.

The construction of the transmission by the user or installer is a critical point for safety.

The transmission is an integral part of the machine, and its construction requires a design process and awareness of the design parameters developed by **KRUGER**.

	<p><b>CAUTION:</b></p> <p><i>To construct the entire transmission and/or install the motor only, the user and/or installer must always request the transmission specifications document. It is absolutely prohibited to construct transmissions with the use of couplings, drive belts and pulleys of types other than those indicated by the transmission specifications document.</i></p>
---	---

	<p><b>CAUTION:</b></p> <p><i>If no inverter is used for gradual starting of the fan, it is absolutely prohibited to use toothed pulleys, as these can cause irreversible damage to fan structures. Consult the <b>KRUGER</b> Technical Office.</i></p>
---	--

	<p><b>CAUTION:</b></p> <p><i>Conditions of overspeed can be caused by drive system faults on fans with direct transmissions.</i></p>
---	--

In the case of directly-coupled fans of high power, starting is a moment of particular stress for rotating mechanical organs.

In the case of fans supplied without an electric motor, incorrect electrical connections to the motor or the wrong motor choice could be the cause of operation at speeds in excess of the original design speed, given that the rotation speed of an asynchronous motor depends on the frequency and the number of poles.

The use of a supply frequency different from the original design frequency affects all fan characteristics. The modification of conditions of use requires a complete revision of the technical information sheet of the fan.

In the case of use at varying fan speeds or with frequent starting and stopping during operation, rotating organs are subject to mechanical stresses that may affect their operative lifespan.

	<p><b>CAUTION:</b></p> <p><i>Fan operation within a very broad range of operating speeds may lead to increased vibration in correspondence with a specific resonance frequency of the system of which the fan is only a single component.</i></p> <p><i>Avoid working at speeds coinciding with structural resonance frequencies, and if this is not possible, modify some variable that can change the resonance frequency of the system, for example by using vibration dampers of a different type.</i></p>
---	--

If the rotation direction of a fan must be inverted, or if it must be restarted, this must be done only when the impeller is in the rest position (total standstill).

	<p><b>CAUTION:</b></p> <p><i>Inverting the fan rotation direction or starting it with the impeller turning in the opposite direction may cause breakage of the blades and/or the impeller hub, with the risk of ejection of metal parts.</i></p>
---	--

The replacement of moving parts with non-original spare parts may be the cause of different operating conditions with respect to the original design condition (e.g. AISI 304 stainless steel, or AISI 316L stainless steel).



**CAUTION:**

*Respect the maximum speeds indicated in the catalogue for the applicable temperature. For transmission shafts in stainless steel, these speeds must be reduced by 20%. Comply with the information given on the transmission specifications document supplied with the fan.*

Operation at a speed significantly lower than up to 40% of nominal speed (unless otherwise specified by **KRUGER**) may affect the cooling of the motor and bearings, with possible malfunctions due to higher temperatures. For electrical components, the user and installer are advised to provide adequate protection for the drive system or motor, with the use of heat detection capsules if possible, and also using a servo-ventilated motor if necessary.

Resonance phenomena in the structure must be avoided. These may emerge at specific rotation speeds, and may cause damage to the structure.



**CAUTION:**

*Resonance phenomena at low frequencies may cause damage to the structure.*

**3.7.6 Noise emission risks**

**KRUGER** designs its fans dedicating attention to the elimination of the noise that they generate. Nevertheless, during normal operation fans act as a sound source.

The spectrum of frequencies of Sound emission depends on the dimensional and structural characteristics of the fan, and also on its application of use (rotation speed, fluid moved, etc.).

**KRUGER**, in collaboration with AMCA, has measured the Sound emissions of its fans in its own test laboratory in accordance with the AMCA 300 standards.



**CAUTION:**

*Vibrations and noise emission are directly correlated. Compliance with the instructions given for correct installation so as to reduce vibrations to a minimum is of equivalent importance for noise reduction.*

Since the noise emitted by a fan can be influenced by external factors that can affect the overall noise level, such as:

- The dimensions of the environment in which the fan is installed
- The presence of static elements near the fan (e.g. walls)
- The presence of other machines that are also sources of noise emission

**KRUGER** invites the user to measure ambient noise levels. It should be noted that the presence of other operating machines generates a "superimposition of effects" and resonance that multiply ambient noise.

In addition, in cases of restricted environments, or if the fan is installed against walls, the effect of reverberation and resonance on structures (walls and ceiling) is "exponential".



**CAUTION:**

*Avoid positioning fans in areas that could increase the noise risk.*

The definition of the risks to workers of exposure to noise is not the responsibility of **KRUGER**, which limits itself to indications of values, levels of uncertainty, standards or criteria used for noise emission measurements.

As envisaged by applicable legislation, it is the user that must assess the level of exposure of operatives to noise emissions using its own specific procedures, identifying:

- Sources of noise and their relative importance
- Average exposure times for each operative
- The level of direct and reflected noise
- The noise transmitted by structures and not through the air

	<p><b>CAUTION:</b> <i>Avoid working positions that increase the noise risk for operatives.</i></p>
---	--

	<p><b>CAUTION:</b> <i>Reducing exposure times and the use of Personal Protection Equipment will reduce the risks caused by exposure to noise emissions.</i></p>
---	---

If exposure to noise, in terms of Sound pressure, exceeds 80 dBA, the employer must provide operatives with Personal Protection Equipment for hearing. If exposure is equal to or higher than 85 dBA, the employer must take all possible action to ensure that Personal Protection Equipment for hearing is effectively used.

	<p><b>CAUTION:</b> <i>With sound pressures higher than 100 dBA, operatives may approach the fan only if it is not operating, even if wearing Personal Protection Equipment.</i></p>
---	---

### 3.7.7 General information on noise emission data

#### Level of Sound power – LwA

This is the average value of Sound power expressed in dBA (value weighted according to scale A) emitted into the environment by a fan with ducting on both the inlet and outlet sides.

The value refers to channelled air with a density of 1.2 kg/m<sup>3</sup>, at the maximum permitted rotation speed of the impeller and with operation at the optimum point on the curve.

It is assumed that the fan is positioned in a free space, or in an area of dimensions such as to not cause significant reflection, and resting on a flat and rigid surface.

The possible contribution to the overall noise level of the noise caused by the motor, the transmission system and any accessories that may be present is not considered.

In addition, the value of background noise of the installation environment is not considered to be significant.

#### Level of Sound pressure – LpA

This is the average of the average temporal values of Sound pressure emitted into the environment by a fan with ducting on both the inlet and outlet sides.

Pressure values are recorded on the measurement surface surrounding the fan (parallelepiped measurement surface).

The pressure value is expressed in dBA (value weighted according to scale A).

The value refers to channelled air with a density of 1.2 kg/m<sup>3</sup>, at the maximum permitted rotation speed of the impeller and with operation at the optimum point on the performance curve.

The measured values refer to a measurement distance of one meter.

It is assumed that the fan is positioned in a free space, or in an area of dimensions such as to not cause significant reflection, and resting on a flat and rigid surface.



The possible contribution to the overall noise level of the noise caused by the motor, the transmission system and any accessories that may be present is not considered.

In addition, the value of background noise of the installation environment is not considered to be significant.

The point at which maximum Sound pressure is found normally corresponds to the outlet duct (external to the ducting), and its value is 3–4% higher than the average value.

## 4 TRANSPORT, MOVEMENT AND STORAGE

Lifting and movement operations with the fan may create hazardous situations for exposed persons. It is therefore advisable to follow the instructions provided by **KRUGER** and to use suitable equipment.

### 4.1 Lifting and movement

It is advisable to carry out all lifting and movement operations on the fan and its components with extreme care, avoiding impacts that may affect its correct operation or damage covered parts.

Use only the points indicated to lift the fan, distributing the load in a uniform manner.



*Lifting points are identified with this symbol.*



**CAUTION:**

*The user assumes liability for the choice of the lifting equipment and ropes, straps or chains considered to be most suitable both for the purpose and for their lifting capacity. For lifting and movement, do not use zones or points other than those marked by a symbol.*

### 4.2 General warnings for lifting separate fan parts

For reasons of transport, some fan parts may be delivered disassembled.



**CAUTION:**

- *All transport operations must be carried out solely by qualified personnel.*
- *The movement of separate or disassembled parts of the machine must be carried out with suitable means of transport.*
- *For the correct movement of these parts, respect the indications on weight provided by **KRUGER**.*



*Generally, special or specific equipment is not necessary for the lifting of fan parts.*

### 4.3 Fan lifting instructions

#### 4.3.1 Lifting version 1 and 9 axial fans

Version 1 fans are supplied without motor. Version 9 fans are supplied with the motor supported by the casing. Version 12 fans have the motor fixed to the base. To lift them, the specific holes provided in the structure must be used (as shown in Fig. 4-1). These holes are located on opposite sides above the center of gravity, and are indicated by specific symbols.

In this case it is advisable to use a chain sling with two arms, the choice of which by the user must be compatible with the weight of the fan. In particular, the user must ensure that the weight load limit (WLL) of the sling is equal to or greater than the load to be lifted.

Slings with several arms (3 or 4) used with a number of arms that is less than the total number of arms composing the sling must be used with a lower WLL than the WLL marked on the sling, applying the factors indicated by standard UNI EN ISO 818-6 - A.1.3.7. It is advisable for unused arms to be gathered and hooked together, to reduce the risk of them swinging freely or being caught up during movement of the load.

Every time that a sling is used, it must be inspected beforehand for possible damage or evident signs of wear.

To connect the sling to the load, it is preferable to use the method with straight arms. In this case, the lower ends are connected directly to the attachment point. The hooks must be chosen so as to ensure that the load settles at the center of the hook, preventing the tip of the hook from being loaded. The hook tips must also be oriented outwards, unless the hooks have been specifically designed for being used otherwise.

Before operating the lifting equipment, it is advisable to check that the load is free to move, and that it is not blocked by connection components or other obstacles to movement.

It is advisable to keep the hands and other body parts away from the chains, to prevent injuries when they are put under load. When lifting operations are ready to start, any slack must be taken up before lifting itself can start. The load must be lifted slowly, checking that it is firmly secured and that it moves into the required position. Reference must also be made to standard ISO 12480-1 to plan and manage lifting operations and to ensure that a safe working system is used.

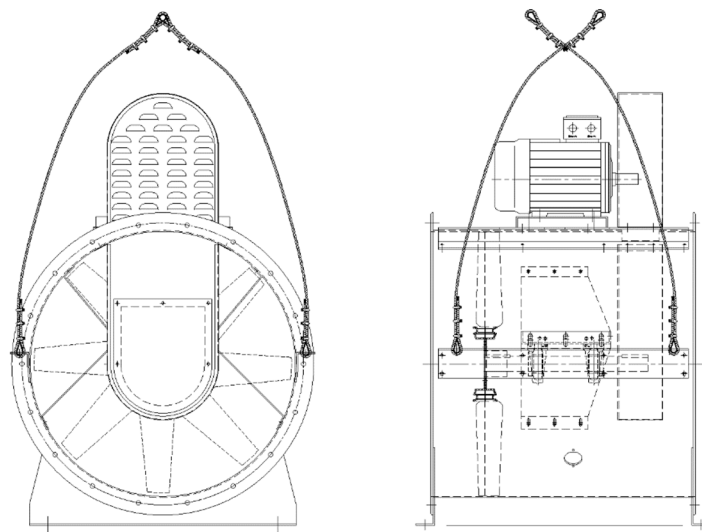

Fig. 4-1 Example of lifting version 1 and 9 axial fans

#### 4.3.2 Lifting version 4 axial fans

Version 4 fans have the impeller fitted directly on top the motor shaft, and to lift them only the holes provided in the structure must be used (as shown in Fig. 4-2). These holes are located on opposite sides above the center of gravity, and are indicated by specific symbols.

For the criteria to be applied in lifting operations the instructions provided in paragraph 4.3.1 must be followed.

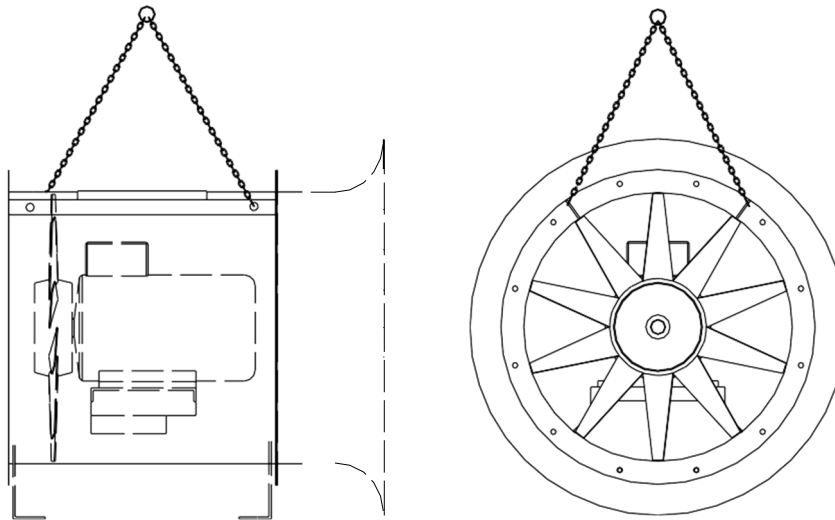

Fig. 4-2 Example of lifting version 4 axial fans



**CAUTION:**

*The lifting lugs on motors must never be used to lift the fan.*

### 4.3.3 Lifting fans packed in crate

The weight and center of gravity of the crate are indicated on the outside of the package.

The lifting points for lifting the crate with a forklift truck are identified by two black triangles with the tip pointing downwards.

**KRUGER** ensures the stability of the fan or of fan components inside the case by means of rigid connections linked directly to the packing, so as to prevent any possible sudden movements of crate contents.

Nevertheless, while moving a crate with a forklift truck, the risk of instability or of the loss of stability caused by unforeseen movements of the forklift remains. To avoid this risk caused by unforeseen movements, care must be taken to carry out movement operations on a flat surface without projections or holes that could affect the stability of the loaded forklift truck. The speed of the forklift truck must also be reduced to a minimum, with the load at the minimum possible height.

Since the stability of the load is ensured when the position of the center of gravity is located at a lower height vertically than the lifting point, whenever possible it is preferable to lift crates using lifting straps and/or chains.



**CAUTION:**

*Before lifting check:*

- *that the capacity of the lifting equipment is compatible with the load*
- *that the lifting equipment is in good condition*
- *that the load has been correctly hooked up in safety*
- *that the lifting point is vertically above the center of gravity of the load*
- *that the operator who carried out hooking up operations has moved away from the lifting areas*



**CAUTION:**

*Positioning of the lifting point at a significant distance from the vertical of the center of gravity of the load can generate dangerous oscillations of the load when lifted.*

The load must be lifted away from the support surface with a very slow initial movement, so as to be able to identify any potential oscillations of the load. If residual oscillations of a nature that could be a hazard for persons or things during transport of the load are present after lifting it away from the support surface, it is advisable to wait for these oscillations to stop before starting transport operations.

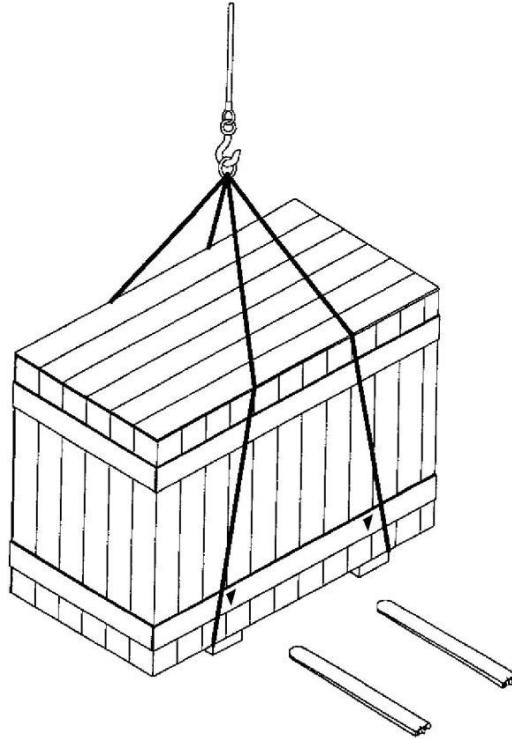

Fig. 4-3 Example of lifting fans packed in crate

#### 4.4 Storage

If the fan is to be stored, it must be protected against weather conditions and damp, dust and the effects of atmospheric and environmental agents.



**CAUTION:**

*Close inlet and outlet openings during storage.*

It is advisable to periodically check the satisfactory state of conservation of the fan, and to manually rotate the impeller about once a month to prevent deformations to bearings.

## 5 INSTALLATION

### 5.1 General information

	<p><b>CAUTION:</b> <i>All assembly operations must be carried out only by qualified personnel.</i></p>
---	--

	<p><i>Generally, special or specific equipment is not necessary for the assembly of fan parts.</i> <i>In the case of assembly of parts requiring a specific procedure, <b>KRUGER</b> will provide the additional information necessary for carrying out the operations correctly.</i></p>
---	---

Special foundations are not necessary for positioning the fan. A well-levelled concrete support surface is sufficient, suitable to withstand the weight load of the fan and the dynamic stresses generated by its normal operation.

**KRUGER** designs and constructs its fans dedicating the greatest possible attention to the elimination of vibrations at their source. During installation, the user and/or installer must take the necessary measures to reduce vibrations from the overall system (fan and ducts).

	<p><i>It is advisable to use Spring vibration isolators and flexible ducts to reduce to a minimum the transmission of vibrations during fan operation.</i></p>
--	--

The support surface must be flat and horizontal, to prevent the bending and misalignment of supports. If necessary, suitable metal spacers must be placed between the fan base and the support surface to ensure perfect adherence. Use the fixing points provided, ensuring that the tightening of nuts and bolts does not deform fan structures.

The support surface must be sufficiently rigid to withstand normal fan vibrations, and must not be subject to phenomena of structural resonance.

If the fan is mounted on a structure raised above floor level, the vibration characteristics of this structure must be verified.

The necessary and sufficient parameters for the definition of the technical characteristics of the support structure to be used for fan installation are as follows:

- static load of the fan
- dynamic load of the fan
- position of the center of gravity of the fan

	<p><b>KRUGER</b> <i>does not</i> consider fixing by means of welding the fan structure to foundation plates to be an acceptable fixing method.</p>
---	--

Ducting connected to the fan must be supported separately, and must be coaxial with respect to the inlet and outlet openings, so as to prevent deformation caused by the tightening of nuts and bolts.

	<p><b>CAUTION:</b></p> <p><i>All installation operations must be carried out solely by qualified personnel, authorized and using suitable equipment.</i></p>
---	--

	<p><b>CAUTION:</b></p> <p><i>During installation, the conservation of the minimum access spaces requested for maintenance operations must be verified.</i></p>
---	--

	<p><b>CAUTION:</b></p> <p><i>The use of flow regulation devices connected directly to the fan inlet may generate unstable operation.</i></p>
---	--

**5.1.1 Minimum installation distances**

If possible in the available space, to guarantee correct entry of the fluid into the inlet opening it is advisable on fans connected to ducting to leave a straight section of duct with a length about 2.5 times the fan size (given on the name plate). The result of this calculation divided by 1000 gives the recommended length (in meters).

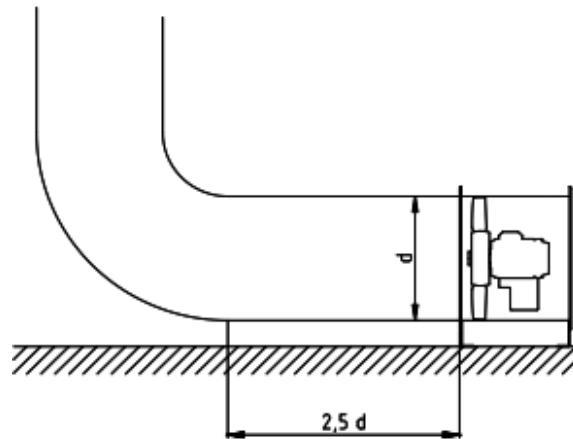

Fig. 5-1 Minimum installation distances with inlet duct

If the fan is installed with a free inlet opening, it must be positioned at a minimum distance from walls or other machinery of 1.5 times the fan size (given on the name plate). The result of this calculation divided by 1000 gives the recommended minimum distance (in meters).

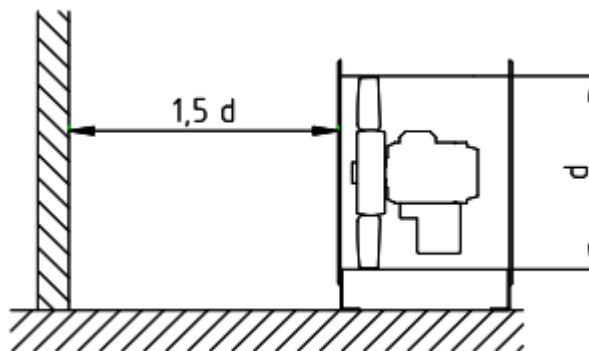

Fig. 5-2 Minimum installation distances with free inlet

## 5.2 Assembly of axial fans

The main steps of the assembly of axial fans in the various versions supplied are illustrated below.

### 5.2.1 Version 4 axial fans

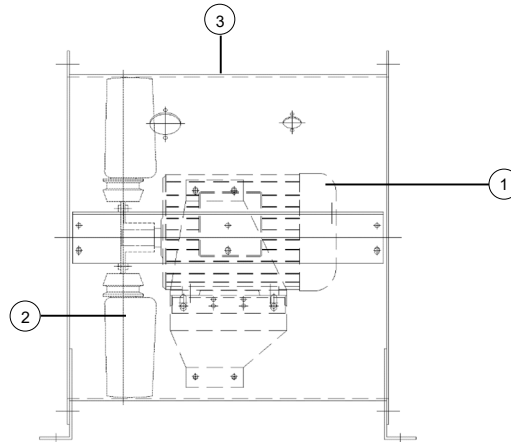

Fig. 5-3 Assembly of version 4 axial fans

Step	Operation	Description
1	Positioning of motor [1]	The motor must be positioned on its base without fully tightening its fixing fasteners.
2	Fitting of impeller [2] on motor shaft	<p> <b>IMPORTANT:</b></p> <p><i>If necessary, reduce the diameter of the motor shaft until its nominal size is reached with a tolerance of +0/+5 microns. Assembly with excessive play can cause vibrations. Forced assembly creates deformations and vibrations, also making it more difficult to remove the impeller.</i></p> <p>After the impeller has been fitted to the projection on the motor shaft and the head washer has been fully fixed, a check must be made to ensure that the clearance between the impeller and the casing <b>(3)</b> is constant around the entire circumference. If clearance is not constant, correct the position of the motor support base.</p>
3	Fixing of motor	Fully tighten the motor fixing nuts.

Table 5-1 Sequence of operations for assembly of version 4 fans  
(refer to Fig. 5-3 for the identification of components)



### 5.2.2 Version 1 axial fans

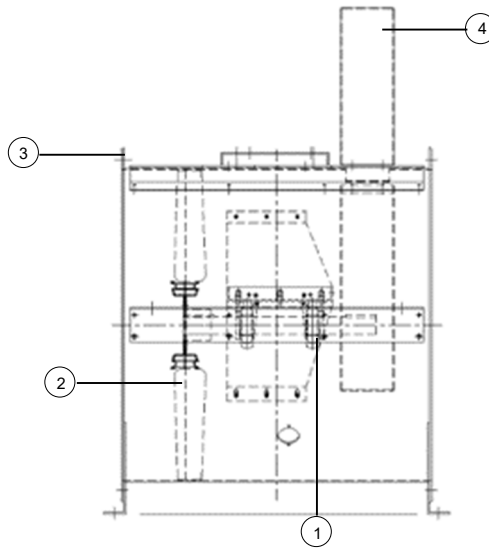

Fig. 5-4 Assembly of version 1 axial fans

Step	Operation	Description
1	Positioning of support [1]	The bearing support must be positioned on its base without fully tightening its fixing fasteners.
2	Fitting of impeller [2] on support	<p> <b>IMPORTANT:</b></p> <p><i>If necessary, reduce the diameter of the motor shaft until its nominal size is reached with a tolerance of +0/+5 microns. Assembly with excessive play can cause vibrations. Forced assembly creates deformations and vibrations, also making it more difficult to remove the impeller.</i></p> <p>After the impeller has been fitted to the projection on the support shaft and the head washer has been fully fixed, a check must be made to ensure that the clearance between the impeller and the casing <b>(3)</b> is constant around the entire circumference. If clearance is not constant, insert shim (spacer) beneath the support feet.</p>
3	Fixing of support	Fully tighten the support fixing.
4	Fitting of protection net [4]	Protect all moving parts with the envisaged protection net.

Table 5-2 Sequence of operations for assembly of version 1 fans  
(refer to Fig. 5-4 for the identification of components)

### 5.2.3 Version 9 axial fans

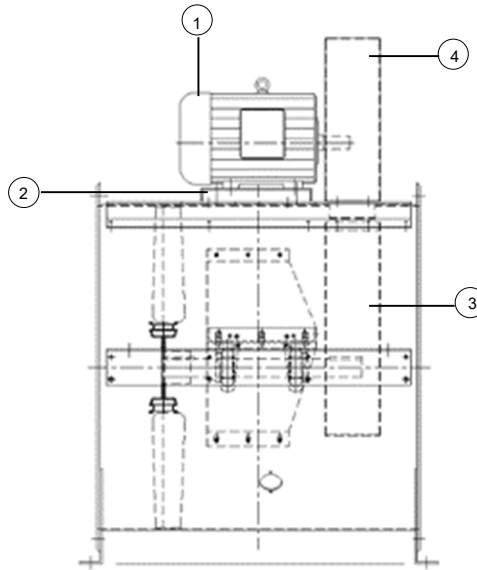

Fig. 5-5 Assembly of version 9 axial fans

After completing steps 1-2-3 indicated in paragraph 5.2.2, proceed with the installation of the transmission.

Step	Operation	Description
1	Installation of motor [1]	Position the motor on its base [2] complete with stays.
2	Fitting of pulleys with tapered bush and fitting and positioning of V-belts [3]	Pulleys must be fitted so as to ensure their correct alignment and tightening. To do this, regulate motor position (see paragraphs 5.3 and 8.2 for fitting and tightening of drive belts). After identifying the correct position, motor fixing fasteners must be fully tightened.
3	Fitting of protection net (4)	Protect all moving parts with the envisaged protection net.

Table 5-3 Sequence of operations for assembly of version 9 fans  
(refer to Fig. 5-5 for the identification of components)

### 5.3 Mounting Configuration

Horizontal mounting configurations are provided with a standard support for both ceiling and floor applications. The mounting configurations and the motor position can be changed in the field. Lifting lugs are provided to assist in the installation.

Version 4

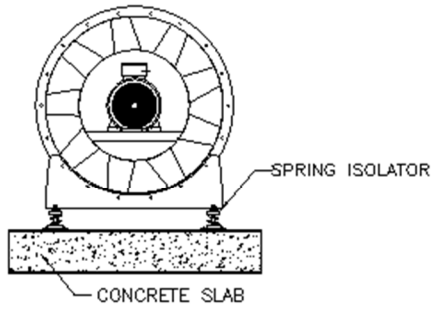

Version 9

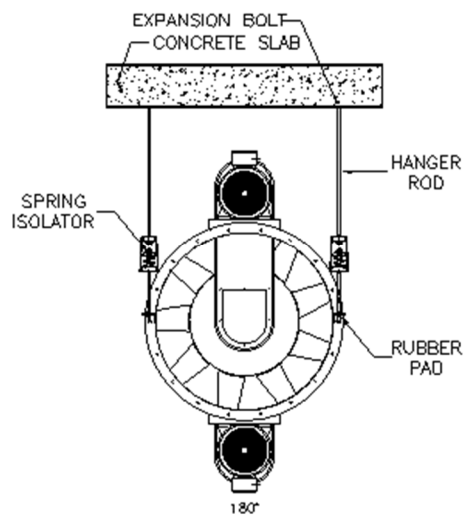
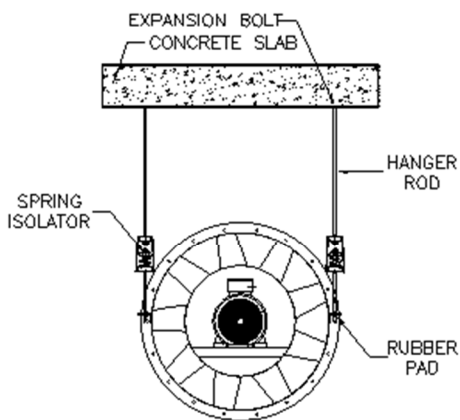
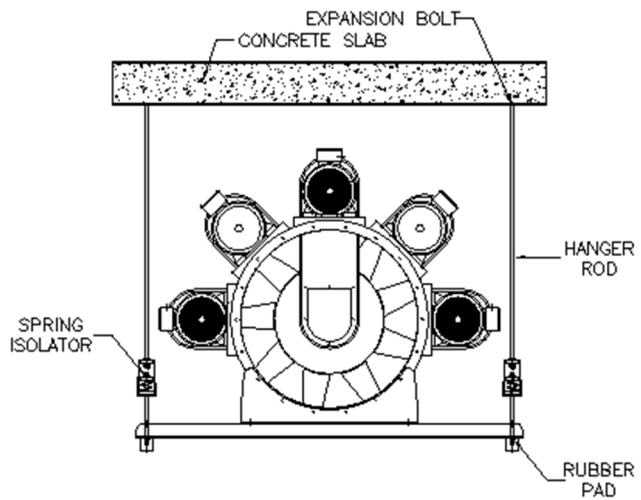
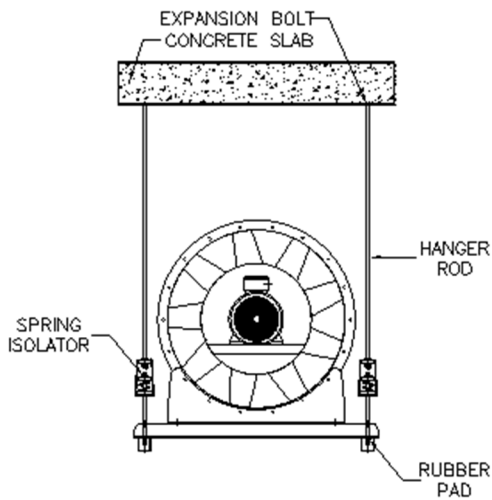
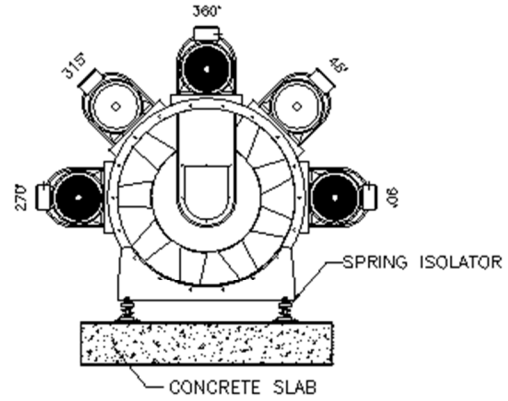

## 5.4 Installing and adjusting drive belts and final checks

If the fan is fitted with a **V-belt drive**, the transmission is assembled as follows:

- Carefully clean tapered parts and the bush hole before fitting it onto the pulley.
- Fit the bush onto the pulley, taking care to align the threaded half-holes on the pulley with the unthreaded half-holes on the bush.
- Screw in the grub screws by hand without fully tightening them.
- Fit the assembly onto the shaft, after carefully cleaning it.
- Position the pulleys and check their alignment with a straight edge.
- Lock in place, tightening screws alternately.
- Fit the belts.
- Do not force the belts with a lever, to avoid damaging the fibers of the internal reinforcement.
- Before tensioning the belts, mark a known length on the taut side (e.g. 100 mm) and, rotating the transmission, gradually tension the belts (as described in paragraph 8.2) until a relative increase in length is obtained of:

0.8% for uniform torque;

1% for irregular torque.



*Excessive belt tension may damage bearings and cause shaft breakage.*

## 5.5 Vibration Isolator Installation

- Choose proper isolator
- Adjust deflection based on the selected isolator.
- Maintain the operating / free height at the same level through step 2 (The entire assembly must be levelled).
- Check all the deflection and operating / free height is properly maintained.
- 25 mm deflection type for SBA / SHA series and 50 mm deflection type for SBB / SHB series.

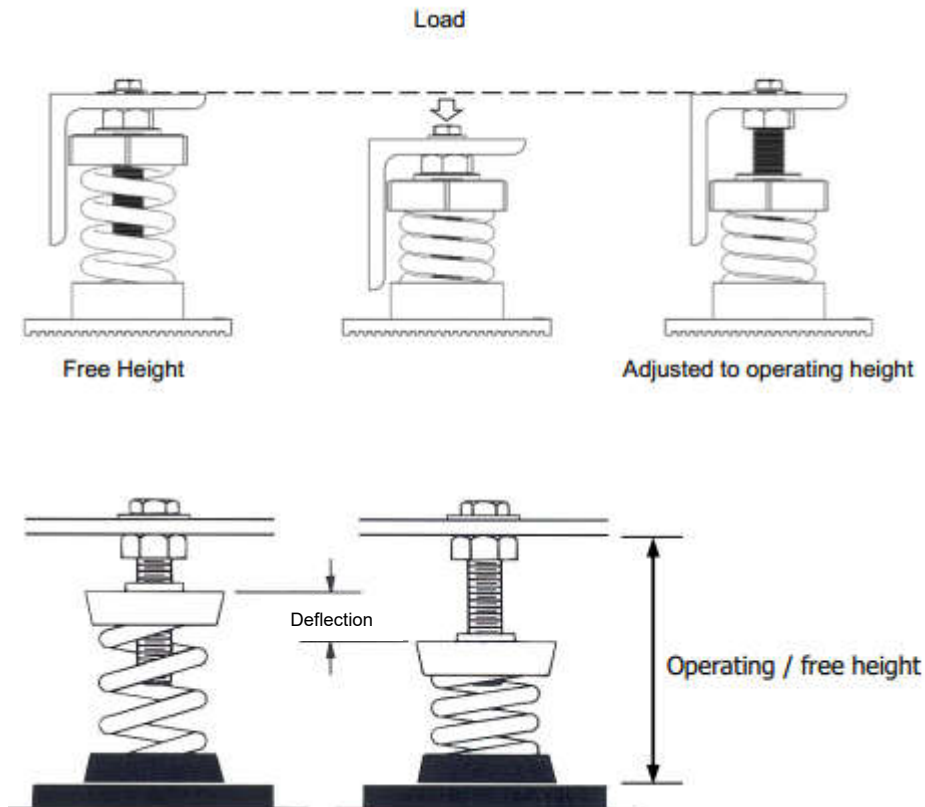



Fig. 5-6 Vibration Isolator setup

## 5.6 Blade adjustment

If the working point of the fan has to be changed and it is necessary to adjust the blade angle, please contact KRUGER Technical Office.

## 5.7 Electrical connections

	<p><b>CAUTION:</b></p> <p><i>The fan is supplied in conformity with Directive 2014/30/EC on electromagnetic compatibility. In particular, the electric motor, if supplied with the fan, is guaranteed by its manufacturer to be conformant to this directive. It is the responsibility of the installer to check that the system in which the fan is inserted is conformant to the directive. If the motor is not supplied with the fan but is fitted by the customer, it is compulsory for the customer to check that it is conformant to the directive.</i></p>
---	---

The mains power supply line to the fan must be able to deliver sufficient power.

Connections to the mains power supply must be made by qualified personnel, remembering that the customer is always responsible for the electrical power supply through to the motor connection terminals.

Customers are reminded of the need to ensure all safety conditions for the grounding of the fan.

The grounding system must be conformant with applicable legislation in the country of installation, and must be regularly checked by qualified personnel.

**Make the connection to the grounding connector before making all other connections.**

Check that the connection layout (see Fig. 5.7) is suitable for the power supply voltage.

Standard electric motors can normally operate indifferently in both rotation directions. To invert the rotation direction, it is sufficient to exchange any two of the power supply cables directly on the terminal board.

	<p><b>CAUTION:</b></p> <p><i>It is the responsibility of the installer to provide an electrical power supply system for the fan in conformity with the EN 60204-1 standard.</i></p> <p><i>In particular, an electrical cut-off switch must be provided near the fan, so that maintenance personnel have direct control over power supply to the fan (see points 9.2.6.3 Enabling Control and 10.7 Emergency Stop Devices of the EN 60204-1 standard).</i></p>
---	---

In addition, the designer of the electrical system must provide controls for starting, normal stopping and emergency stopping, in conformity with Annex I of MACHINERY DIRECTIVE 2006/42/EC.

	<p><b>CAUTION:</b></p> <p><i>It is the responsibility of the customer and/or electrical installer to choose the correct size and type of the device and of cables used for electrical connections to the fan, depending on the motor installed and the mains power supply system.</i></p>
---	---

Work may be done on electrical components only with the fan at a standstill and disconnected from the electrical power supply.

Before installation and starting, check that the data on the motor name plate are in conformity with the characteristics of the electrical power supply system.

*The layouts shown are merely indicative. Consult the connection layout provided by the motor manufacturer.*

Three-phase single-speed motors	Three-phase motors Single winding Single voltage	Three-phase motors Two separate windings Single voltage
Delta connection	Dahlander connection for high speed	Connection for high speed
Star connection	Dahlander connection for low speed	Connection for low speed

Fig. 5-7 Diagram of electrical connections for single-speed and two-speed motors

Openings for cable entries must be made in a way that prevents the cables from coming into contact with sharp edges or moving parts, and in particular the impeller. If openings for cable entries must be made in the casing, the openings must be fitted with suitable protective devices (grommets). In this case, consult the KRUGER Technical Office. These precautions are applicable in particular if an external terminal box is fitted.

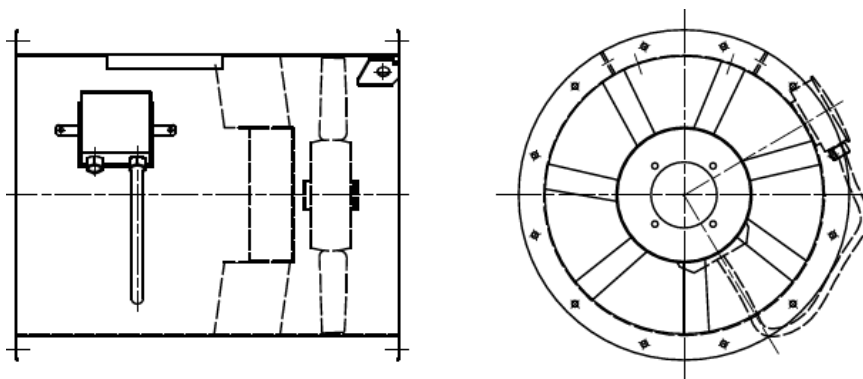

Fig. 5-8 Example of positioning of external terminal box

### 5.8 Connection to ducts

The fan must be connected to ducting with all parts correctly aligned, without obstructions to air flow from gaskets or flexible components. The weight of ducting must not be supported by the fan, and deformations of parts of the machine by ducting connections must be avoided. Any flexible joints between the fan and inlet and/or outlet ducts must be installed in a way that prevents stress on flexible components, and that avoids contacts between metallic parts of the joints (see fig. 5-9 for assembly tolerances).

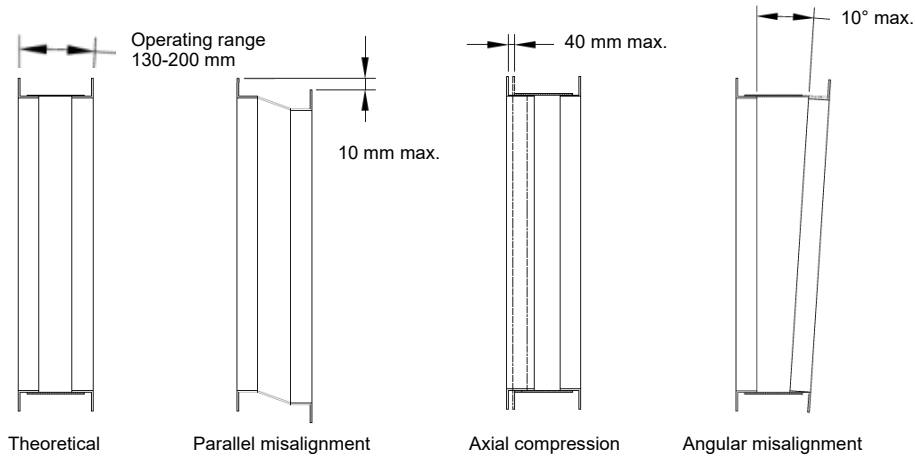

Fig. 5-9 Assembly tolerances for flexible joints

If possible in the available space, to guarantee correct entry of the fluid into the inlet opening it is advisable on fans connected to ducting to leave a straight section of duct with a length about 2.5 times the fan size (given on the name plate). The result of this calculation divided by 1000 gives the recommended length (in meters).

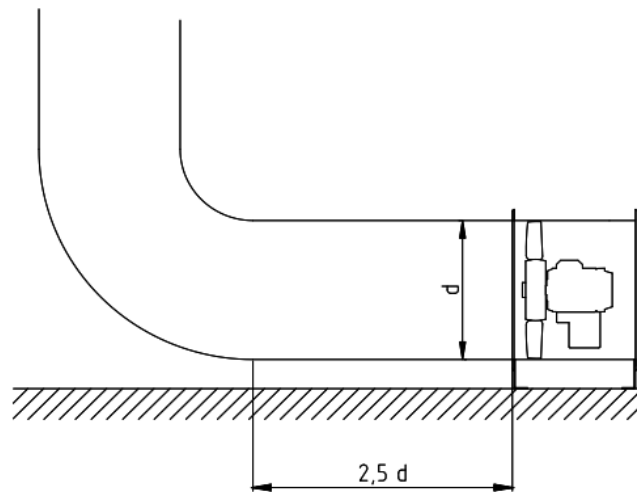



Fig. 5-10 Minimum installation distances with inlet duct



## 6 CHECKS TO BE MADE BEFORE AND AFTER STARTING

### 6.1 Preliminary checks

	<p><b>CAUTION:</b></p> <p><i>Checks before the first starting must be made only with the fan at a standstill and disconnected from the electrical power supply.</i></p>
---	---

Before the fan is started for the first time a number of preliminary checks are necessary:

- Verify the compatibility of the fan for its intended application.
- In case of completion of the transmission by the installer, verify the compatibility of the fan name plate with the transmission specifications document.
- Check that all protection nets are present.
- Check that all nuts, bolts and other fasteners envisaged by **KRUGER** are present.
- Check that all nuts, bolts and other fasteners (impeller, supports, foundation, transmission if present) are correctly tightened.
- Check the correct lubrication of the fan and motor bearings, and if necessary replace the grease (see chapter 8 MAINTENANCE).
- Check that all rotating parts can turn freely.
- Check for the absence of objects or foreign bodies inside the fan.
- Check that the rotation direction is correct. A short burst of electrical power is sufficient to check that the rotation direction is the same as that indicated on the fan casing. If necessary invert the rotation direction (see Electrical connections).

**KRUGER** recommends the use of the checklist given in paragraph 11.2 to record the necessary checks for safety conditions.

	<p><b>CAUTION:</b></p> <p><i>Operating trials must not be permitted before the checks of the checklist have been made (see paragraph 11.2).</i></p>
---	---

	<p><b>CAUTION:</b></p> <p><i>Axial fans must never operate with their openings completely closed.</i></p>
---	---

## 6.2 Checks to be made with fan fully operating

Check that power absorption does not exceed the value indicated on the motor name plate. If it does, **immediately halt the fan and contact the manufacturer.**

Fan operation must be free from excessive vibrations and abnormal noise.

With the fan at a standstill, check that the temperature of the bearings does not exceed the limits of tolerance (with an ambient temperature of 20°C, the temperature of supports must be no higher than 70°C). It must be taken into consideration that in the first hours of operation, a higher temperature than that indicated may be normal, if it then falls to a lower value. In case of abnormal overheating of bearings, consult the **KRUGER** technical service.

After 3–4 hours of operation, with the fan at a standstill and disconnected from the power supply, repeat the checks on the tightness of nuts and bolts, bearing temperatures, and for fans with transmission, the temperature and tension of drive belts.

With regard to vibrations, the criterion for the verification of conditions of safety refers to standard ANSI/AMCA 204:2005, which recommends the following limits for mechanical vibrations (vibration speed in mm/s RMS), measured in installation conditions:

- **alarm: 4.5 (rigid), 7.1 (flexible);**
- **stop: 7.1 (rigid), 11.2 (flexible);**

These limits are considered to be valid by **KRUGER** in general, with the exception of specific indications for individual applications.

Measurement point and direction: on fan supports or motor, in a direction perpendicular to the rotation axis, on the horizontal or vertical plane.

The use of the definition of rigid and flexible refers to the fact that the structure reaches its first critical speed higher or lower respectively than operating speed. **KRUGER** fans normally have a rigid structure with regard to this definition.

The type of vibration damper used affects the value of the first critical speed.

The reference limits for temperature on supports, measurable on the external bearing ring regardless of ambient temperature, are as follows:

- **alarm 100 °C;**
- **stop 120 °C;**

### 6.2.1 Visual checks on protection net

For protection net, checks must be made for the following:

- Corrosion or dullness of galvanized surfaces
- Detachment of rivets/welds
- Evidence of noises typical of loose protection net
- Impacts and permanent deformation of components
- Breakage of wires
- Corrosion of fasteners
- Slackening of fixing elements

**CAUTION:**

*All protection net must be inspected every month and replaced if necessary.*

**CAUTION:**

*In case of doubts, carry out checks more frequently or replace the protection net.*

### 6.2.2 Checking and cleaning parts in contact with fluids

The periodical cleaning of the impeller prevents vibrations that might be caused by any dust deposits that accumulate while the fan is running.

**If the fan is used for the movement of even slightly dusty fluids, the Impeller must be inspected periodically for cleanness and/or wear.**

Deposits of material or wear on impeller parts may cause abnormal fan vibrations.

### 6.2.3 Visual checks on impeller and casing

Periodical visual checks must be made for wear on impeller blades, given that deterioration of these parts can create a condition of extreme risk, due to the ejection of the blade or the failure of structural components, with consequences that may even be fatal.

**CAUTION:**

*Axial fans must not be used for fluids containing abrasive agents.*

To monitor **phenomena of accidental abrasion** on impeller blades and the casing, use a portable lamp to visually inspect components, slowly rotating the impeller to allow all blades to be seen. Blades must be totally free from damage and must show no signs of abrasion or missing sections.

With regard to the **phenomenon of corrosion** on impeller blades and the casing, corrosive and acidic environments can reduce the thickness of fan safety components.

This phenomenon must not be underestimated, also because it does not depend solely on the concentration of aggressive agents.

Condensation may form during pauses in fan operation, and this may accelerate the phenomenon of chemical corrosion, which in turn may alter the thickness of components, affecting their integrity.

#### 6.2.4 Dimensional checks

CHECKLIST – DIMENSIONAL CHECKS ON COMPONENTS			
COMPONENTS TO CHECK	TYPE OF CHECK/INSTRUMENT	CRITERIA FOR ACCEPTABILITY	RESULT
Impeller: presence of scratches or grooves on surfaces	Visual	Undamaged	OK <input type="checkbox"/>
Casing: sheeting thickness	Dimension/Caliper or equivalent	Reduction of thickness no greater than 10% in an area without wear	OK <input type="checkbox"/>
Inlet: thickness (if present)	Dimension/Caliper	Reduction of thickness no greater than 20% in an area without wear or with paint undamaged	OK <input type="checkbox"/>
Flexible ducts: thickness of anti-wear sheeting (if present)	Dimension/Caliper	Reduction of thickness no greater than 20% in an area without wear or with paint undamaged	OK <input type="checkbox"/>
Welding (entire structure)	Visual	Absence of damage and cracks	OK <input type="checkbox"/>
Date:			
Signature:			

## 7 AXIAL FAN OPERATING MALFUNCTIONS

### 7.1 Most frequent malfunctions

The following Table lists the main problems that may be encountered:

PROBLEM	CAUSE	SOLUTION
Power absorption lower than design value	Rotation speed too low	Increase rotation speed
	Impeller partially blocked	Eliminate obstruction
	Resistance pressure of system lower than design value	Check the resistance pressure value of the system
	Fluid density lower than intended value	Check the fluid density value
	Incorrect blade angle	Increase blade angle
Power absorption higher than design value	Rotation speed too high	Reduce rotation speed
	Resistance pressure of system greater than design value	Check the resistance pressure value of the system
	Openings or ducting partially blocked	Eliminate obstruction Check the position of adjustment organs
	Pre-rotation of air in opposite direction to fan rotation	Check minimum installation distances (paragraph 5.1.1)
	Fluid density higher than intended value	Check the fluid density value
	Power supply to motor with voltage lower than shown on name plate	Check for correct voltage of power supply to motor
	Defects in motor windings	Check for correct motor operation
	Incorrect blade angle	Reduce blade angle
Insufficient pressure	Rotation speed too low	Increase rotation speed
	Fluid density lower than intended value	Check the fluid density value
	Air flow greater than intended value	Check the resistance pressure value of the system
Pulsating operation	Instability of air flow	Check operating field envisaged by operating curve
	Fluctuations in flow due to other fans operating in parallel	Check for correct installation on system
	Inlet air turbulence created by system near inlet opening	Check minimum installation distances (paragraph 5.1.1)
Vibrations	Pulsating operation	See previous point "Pulsating operation"
	Structural resonance at specific rotation speeds	Use the inverter to avoid operation at these speeds or modify frequencies of the overall system
	Wear on impeller parts	Inspect the impeller
	Deposit of material on impeller	Inspect the impeller
	Friction between moving parts	Check for correct coupling between moving parts

PROBLEM	CAUSE	SOLUTION
	Intrinsic bearing defects	Check condition of bearings
	Bearing malfunctions due to unbalanced impeller or excessive belt tension	Check condition of bearings Check belt tension (see paragraph 8.2)
Excessive noise	Friction between moving parts	Check for correct coupling between moving parts
	Vibrations	See previous point "Vibrations"
	Pulsating operation	See point "Pulsating operation"
	Electromagnetic motor malfunctions	Check for correct conditions of power supply to motor (inverter)
	Presence of holes or sharp projections	Check for presence of rounded projections in points with high air speed

## 8 MAINTENANCE



*Read this section carefully before carrying out maintenance operations on the fan. This will ensure greater conditions of safety for maintenance personnel and greater reliability of the work done.*

The safety rules to be respected during maintenance operations on the fan are as follows:

- Maintenance and/or lubrication operations must be carried out only by qualified and expert personnel, authorized by the technical management of the factory, in conformity with applicable safety directives and standards, using tools, equipment and products suitable for the purpose.
- During maintenance operations, suitable clothing must be worn, such as closely-fitting overalls and safety footwear, absolutely avoiding garments that are bulky or with loose parts.
- During maintenance operations on the fan, it is advisable to fence it off and to identify it with signs with the wording: "FAN UNDERGOING MAINTENANCE".



**CAUTION:**

*The fan must be disconnected and isolated from the electrical power supply during maintenance operations. Always check that the impeller and motor are at a standstill before accessing the fan and its components or opening the inspection hatch.*

*In the case of fans that move hot fluids, wait for the fan to cool down before carrying out maintenance operations, so as to prevent contact with surfaces at high temperatures.*

In the case of maintenance operations on rotating parts or parts inside ducts, it is also necessary:

- where present, to disconnect the flexible motor coupling;
- where present, to remove drive belts from pulleys.



**CAUTION:**

*In the case of use of a multi-stage fan, disconnect the electrical power supply **from the entire multi-stage fan** and check that the impeller is at a total standstill before carrying out any maintenance operation.*

The person responsible for maintenance must use a team of persons so as to guarantee absolute coordination between the persons and the maximum safety for persons exposed to risk. All persons preparing to carry out maintenance operations must be in full visual contact to warn of possible hazards.



**CAUTION:**

*Any necessary movement of parts to be removed or disassembled from the machine must be made with suitable transport and lifting equipment.*



*Generally, special or specific equipment is not necessary for the fan maintenance operations.*



*Full systematic maintenance of the fan is necessary for its normal correct operation, and is also a factor of safety for operatives.*

To facilitate the planning of programmed maintenance, **KRUGER** has compiled a Table (see paragraph 11.3) with general indications of the points to be monitored and the frequency of checks.



*Periodic cleaning and maintenance, together with lubrication, are essential to ensure correct fan operation and a longer operative lifespan of the fan.*

## 8.1 Bearing lubrication

Maintenance should always be performed by experienced and trained personnel.

For enclosed motor, keep motor vent-pipe (inlet/outlet) from blocking for optimum cooling effect. Grease motor bearing as recommended by motor supplier. The following is general reference for motor greasing:

Frame	Bearing DE	Bearing NDE	Grease Weight Full (g) 100%	Grease Weight Standard (g) 80%
56	6201ZZC3	6201ZZC3	2.5	2.0
63	6201ZZC3	6201ZZC3	2.5	2.0
71	6202ZZC3	6202ZZC3	5.0	4.0
80	6204ZZC3	6204ZZC3	6.3	5.0
90	6205ZZC3	6205ZZC3	8.8	7.0
100	6206ZZC3	6206ZZC3	11.3	9.0
112	6306ZZC3	6306ZZC3	21.3	17.0
132	6308ZZC3	6308ZZC3	26.3	21.0
160	6309C3	6309C3	65.0	52.0
180	6311C3	6311C3	106.3	85.0
200	6312C3	6312C3	128.8	103.0
225	6313C3	6313C3	150.0	120.0
280 2P	6314C3	6314C3	196.3	157.0
280 4P-8P	6316C3	6316C3		
315 2P (Horizontal)	6316C3	6316C3		
315 2P (Vertical)	6316C3	7316		
315 4P-8P (Horizontal)	NU319C3	6319C3	317.5	254.0
315 4P-8P (Vertical)	NU319C3	7319	317.5	254.0
355 2P (Horizontal)	6319C3	6319C3	317.5	254.0
355 2p (Vertical)	6319C3	7319	317.5	254.0
355 4P-8P (Horizontal)	NU322C3	6322C3	515.0	412.0
355 4P-8P (Vertical)	NU322C3	7322	515.0	412.0

Table 8-1 Bearing Grease Weight Standard of TACBECON SGHT 200S (Class F)/ 600 (Class H)



Bearing number		600 RPM	720 RPM	750 RPM	900 RPM	1000 RPM	1200 RPM	1500 RPM	1800 RPM
62XX	6210								
63XX	12								
72XX	13								
73XX	14								
	15								
	16								
	17							2000Hrs	
	18				3000Hrs				
	20								
	22								
	24							1500Hrs	
	26								
	28					2000Hrs		1000Hrs	
	30								
	32							500Hrs	
	34					1500Hrs			
	36								
	38			2000Hrs		1000Hrs			

Bearing number		600 RPM	720 RPM	750 RPM	900 RPM	1000 RPM	1200 RPM	1500 RPM	1800 RPM
NU2XX	NU214								
NU3XX	15							2000Hrs	
	16								
	17								
	18				3000Hrs			1500Hrs	
	20								
	22							1000Hrs	
	24					2000Hrs			
	26								
	28							500Hrs	
	30								
	32				2000Hrs				
	34					1000Hrs			
	36								
	38	2000Hrs							
	40				1000Hrs				
	44								
	48	1000Hrs							

Table 8-2 Relubrication intervals and quantity of grease according to fan rotation speed

Check and lubricate bearings at the intervals recommended by the motor manufacturer. It is always advisable to periodically substitute bearings with replacements as indicated on the motor name plate.

	<i>Use the type of grease recommended by the motor manufacturer to lubricate motor bearings.</i>
---	--

## 8.2 Adjusting drive belt tension and cleaning belts

A simplified method for setting the correct tension of V-belts is as follows: Table 8-2 can be used to obtain the value P of the load for each belt for the profile type and the diameter of the smaller pulley. The value L can also be obtained from the same Table.

Use this formula:

$$L_e = \frac{LxI}{100}$$

to calculate the value  $L_e$ , where:

$L_e$ = deflection [in mm] of the section at the center point of distance I between pulley centers  
 $L$ = deflection for distance between centers of 100 mm

$I$  = distance between centers [in mm]

Applying load P perpendicularly to the section (Fig. 8-1) the transmission must be tightened until the calculated deflection  $L_e$  is reached.

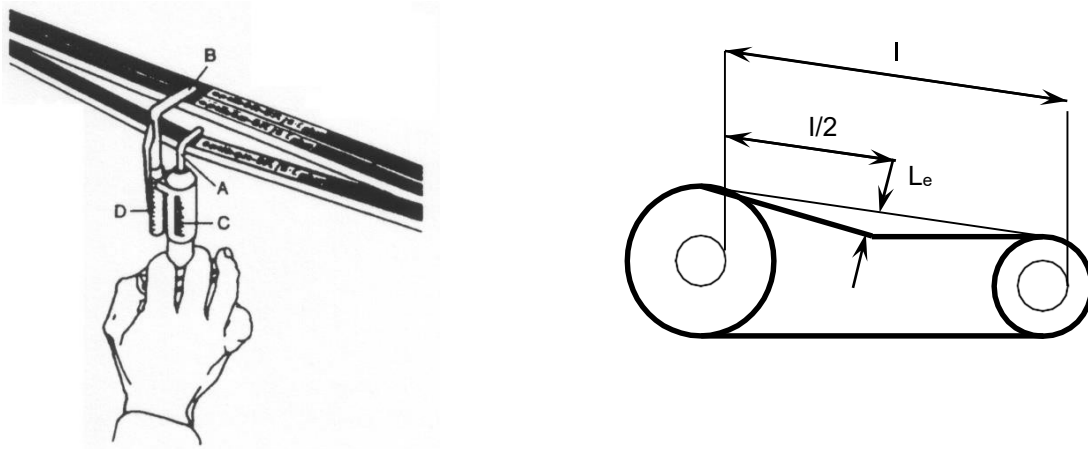

Fig. 8-1 Checking drive belt tension

Profile	Load on belt P [N]	Diameter of smaller pulley d [mm]	Deflection for distance between centers of 100 mm L
SPZ	25	from 63 to 71	2.45
		from 75 to 90	2.20
		from 95 to 125	2.05
		over 125	1.90
SPA	50	from 100 to 140	2.75
		from 150 to 200	2.55
		over 200	2.45
SPB	75	from 160 to 224	2.55
		from 236 to 355	2.22
		over 355	2.10
SPC	125	from 224 to 250	2.55
		from 265 to 355	2.20
		from 400 to 560	2.00
		over 560	1.90

Table 8-3 Setting drive belt tension: test load and deflection

Check drive belt tension at least after about the first 8 hours of operation, and then follow the indications given for programmed maintenance (see paragraph 11.3).

Completely replace belts when worn to a degree that affects satisfactory operation of the transmission due to an insufficient value of pre-tension or if slipping is more than 4-5%. Belt wear depends on various factors, including environmental factors, the number of operation hours, and the number and type of start-ups.



*The manufacturers of standard V-belts recommend that an ambient temperature of 80°C should not be exceeded. For higher temperatures, special belts are necessary.*

Dirty belts must not be cleaned with solvents like petrol, benzene, turpentine, etc., or with abrasive or sharp instruments.

It is advisable to use a solution of alcohol and glycerine in a proportion of 1:10. The transmissions installed on **KRUGER** fans have two or more drive belts.



*In the case of breakage of one or more belts, it is advisable to replace the entire set.*

### 8.3 Checking and cleaning parts in contact with fluids

Periodic impeller cleaning makes it possible to avoid vibrations caused by any dust deposits that accumulate during fan operation.



*If the fan is to be used to move fluids that are even slightly dusty, the impeller must be checked periodically for cleanness and/or wear.*

Deposits of material or wear on some impeller parts can produce abnormal fan vibrations.

If there are parts that are excessively worn, it is essential to replace the impeller (for this operation contact the **KRUGER** Technical Service).



*For all information and for any modifications to be made on our products, please contact the **KRUGER** technical office in advance, specifying the machine type and serial number given on the fan name plate.*

## 9 DISMANTLING AND REASSEMBLING ESSENTIAL COMPONENTS

	<p><b>CAUTION:</b></p> <p><i>All dismantling and reassembly operations described below must be carried out solely by qualified and authorized personnel.</i></p>
---	--

	<p><b>CAUTION:</b></p> <p><i>All dismantling and reassembly operations described below must be carried out:</i></p> <ul style="list-style-type: none"> <li>• <i>With the absolute certainty that the fan is at a complete standstill (impeller stationary); disconnect the power supply to the main control panel with the power switch and apply a lock with key to be consigned to the person responsible for maintenance.</i></li> <li>• <i>After having created a work environment with all necessary equipment and free from all other activities that could dangerously interfere with dismantling and reassembly operations.</i></li> <li>• <i>After carefully cleaning, degreasing or lubricating, according to use, all components dismantled and reassembled.</i></li> </ul>
---	--

### 9.1 Fan impellers with hub

If the working point of the fan has to be changed and it is necessary to adjust the blade angle, please contact KRUGER Technical Office.

	<p><b>CAUTION:</b></p> <p><i>The impeller must be moved with care, avoiding impacts that could alter its base or deform it.</i></p>
---	---

### 9.2 Replacing drive belts

#### 9.2.1 Assembling and dismantling pulleys

<p>1. Check that the motor shaft and the transmission shaft are parallel.</p>	
<p>2. Before fitting the bush (Photo 1) into the pulley, carefully clean tapered parts and the bush hole.</p>	
	<p>Photo 1</p>

3. Fit the bush into the hole in the pulley, taking care to align the threaded half-holes on the pulley with the unthreaded half-holes on the bush (Photo 1). There may be 2 or 3 of these holes (Fig. 9.1), as can also be seen in Table 9.1, depending on pulley size.

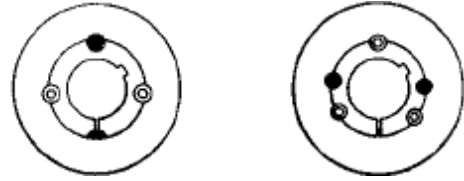

Fig. 9.1 Pulley holes

4. Screw in the grub screws by hand without fully tightening them (Photo 2).



Photo 2

5. Check that the shaft surface is totally clean, and insert the fixing spline into its slot (Photo 3).

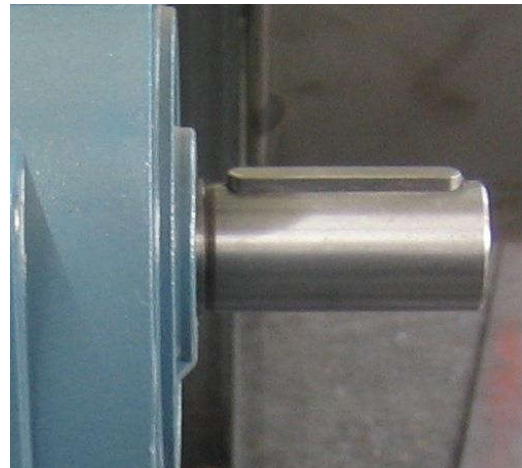

Photo 3

6. Fit the assembled bush, grub screws and pulley onto the motor shaft with the spline inserted in the corresponding slot in the bush hole. If necessary, widen the bush hole by inserting a suitable tool into the bush slit (Photos 4 and 5).



Photo 4

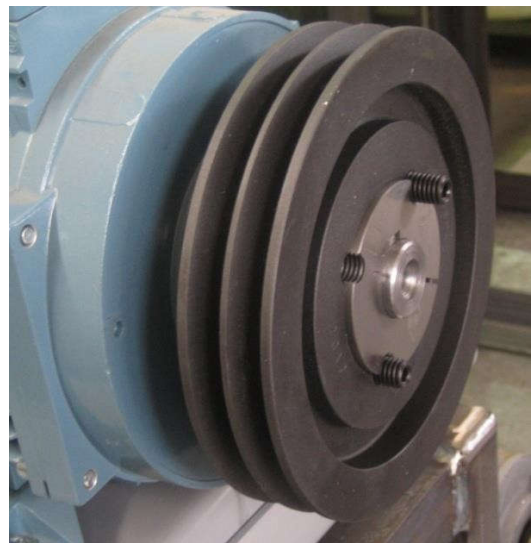

Photo 5

7. Always check that there is a minimum of clearance between the spline and the corresponding slot (Photo 6).

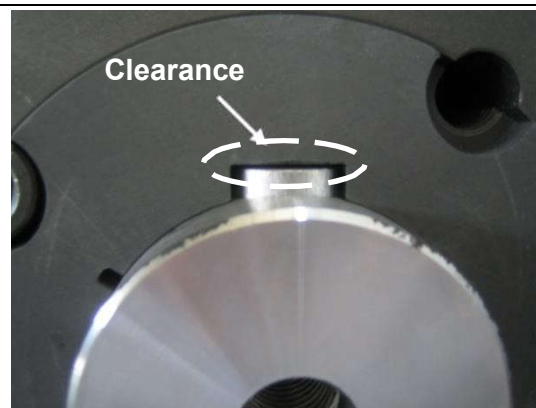

Photo 6

8. Repeat operations 2 to 7 to fit the pulley onto the transmission shaft.

9. Use a straight edge of a suitable length to check correct alignment of the pulleys (Photo 7). Use a rubber hammer to move pulleys axially until the parallel misalignment has been corrected (Photo 8).



Photo 7

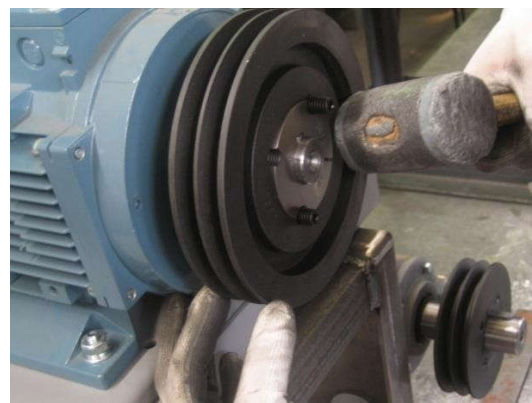

Photo 8

10. Adjust motor position to correct misalignment (Fig. 9.2 and 9.3).

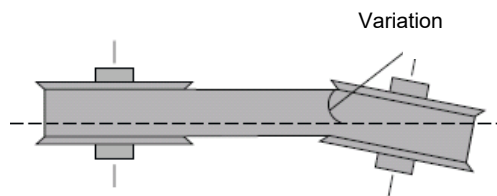

Fig. 9.2 Angular misalignment

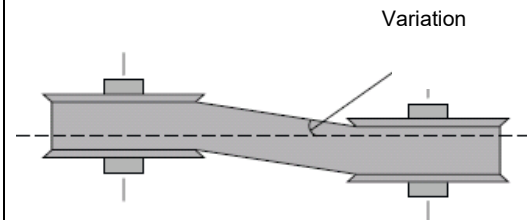

Fig. 9.3 Parallel misalignment

11. Tighten the pulley grub screws alternately (Photo 9) until the tightening torque indicated in Table 9.1 is reached.



Photo 9

12. Check correct pulley alignment again.



**CAUTION:**

*Incorrect alignment causes excessive wear and greater friction on drive belts, higher power absorption by the transmission, noise and vibrations that reduce the effective lifespan of the transmission.*

Generally, the tolerance in pulley alignment in V-belt drive transmissions may not be greater than 0.5 degrees or 5 mm for each 500 mm of distance between centers (Figs. 9.2 and 9.3).



**CAUTION:**

*To remove pulleys, unscrew the grub screws used to fix them and insert one or two of them in the free holes, screwing them in until the bush is detached.*

Type (Max. bore diameter [mm])	Bush		Grub screws				
	Length [mm]	Max. diameter [mm]	N°	Whitworth	Length [mm]	Socket size	Tightening torques [Nm.]
<b>1008</b> (25)	22	35	2	1/4	13	3	5.7
<b>1108</b> (28)	22	38	2	1/4	13	3	5.7
<b>1210</b> (32)	25	47	2	3/8	16	5	20
<b>1215</b> (32)	38	47	2	3/8	16	5	20
<b>1310</b> (35)	25	52	2	3/8	16	5	20
<b>1610</b> (42)	25	57	2	3/8	16	5	20
<b>1615</b> (42)	38	57	2	3/8	16	5	20
<b>2012</b> (50)	32	70	2	7/16	22	5	31
<b>2517</b> (65)	45	85	2	1/2	25	6	49
<b>3020</b> (75)	51	108	2	5/8	32	8	92
<b>3030</b> (75)	76	108	2	5/8	32	8	92
<b>3535</b> (90)	89	127	3	1/2	38	10	115
<b>4040</b> (100)	102	146	3	5/8	44	14	172
<b>4545</b> (110)	114	162	3	3/4	51	14	195
<b>5050</b> (125)	127	178	3	7/8	57	17	275

Table 9-1 Tightening torques



**9.2.2 Assembling and dismantling drive belts**

1. After checking correct pulley alignment, fit the belts. Tools should not be used to force the belts into place on the pulleys (Photos 10, 11 and 12). If necessary, reduce the distance between pulley centers by moving the motor closer.

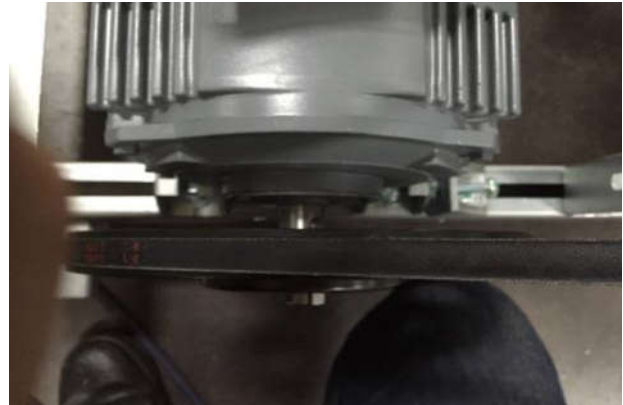

Photo 10

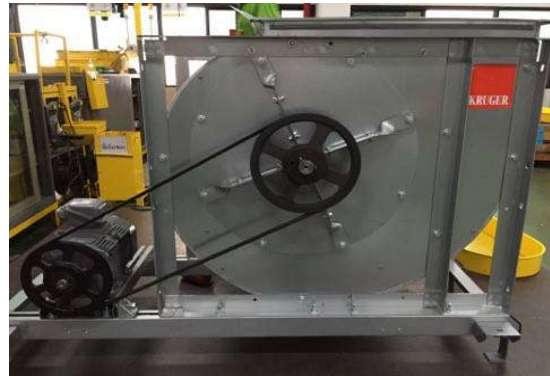



Photo 11



Photo 12

2. Check belt tension. For this operation, see paragraph 8.4 of this manual.

3. If the tension of belts is insufficient, the motor must be moved to tension them correctly.

4. Check correct pulley alignment again.	
5. Fit the complete system of transmission protection devices.	
	<b>CAUTION:</b> <i>After the first 8 hours of operation, stop the fan and check that pulley assembly screws are still fully tightened.</i>
6. To remove the drive belts, repeat the previous operations in the reverse order.	

## 10 FINAL DISMANTLING AND DISPOSAL OF FANS

At the end of the life cycle of the fan, the machine and its accessories must be dismantled as indicated below, so as to allow the various components to be disposed of differently according to the type of material from which they are made. Before demolishing the machine, the user must drain the grease present in bearing supports and generally clean the various components.



**CAUTION:**

*Particular attention must be dedicated to the possible presence of residues of toxic and/or corrosive substances left by the fluid moved.*

Most of the components (casing, motor pedestal, inlet, bearings, protection net, pulleys, bushes) are made of metallic materials (steel and cast iron), and can therefore be disposed of together.

Impellers are made from the aluminium materials.

The electric motor must instead be separated and disposed of at a facility specializing in the elimination of electrical wastes, together with any electric servomotors.

Drive belts are made for rubber, and vibration dampers are also made mainly from the same material.

Most of the accessories are also made from metals, except for flexible ducts, constituted by two metallic flanges bolted together and separated by a textile joint in PVC or aluminumized glass fiber.

Fan dismantling operations can be carried out either in the place of installation, if the need for safe working conditions allows this, or in some other location, after removing and transporting the fan as indicated in Chapter 4 of this manual.



**CAUTION:**

*All dismantling operations described below must be carried out solely by qualified and authorized personnel.*



**CAUTION:**

*All dismantling operations must be carried out*

- *With the absolute certainty that the fan is at a complete standstill (impeller stationary), after the motor has been disconnected from the electrical power supply by qualified and authorized persons.*
- *After having created a work environment with all necessary equipment and free from all other activities that could dangerously interfere with dismantling operations.*



*Special or specific equipment is not necessary for the dismantling of fan parts.*

Dismantling operations can be carried out following the detailed assembly instructions given in Chapter 10 in the reverse order.



**CAUTION:**

Regardless of the installation type, all connection connected to the fan flange must be disconnected and removed before proceeding.

## 10.1 Version 4 axial fans

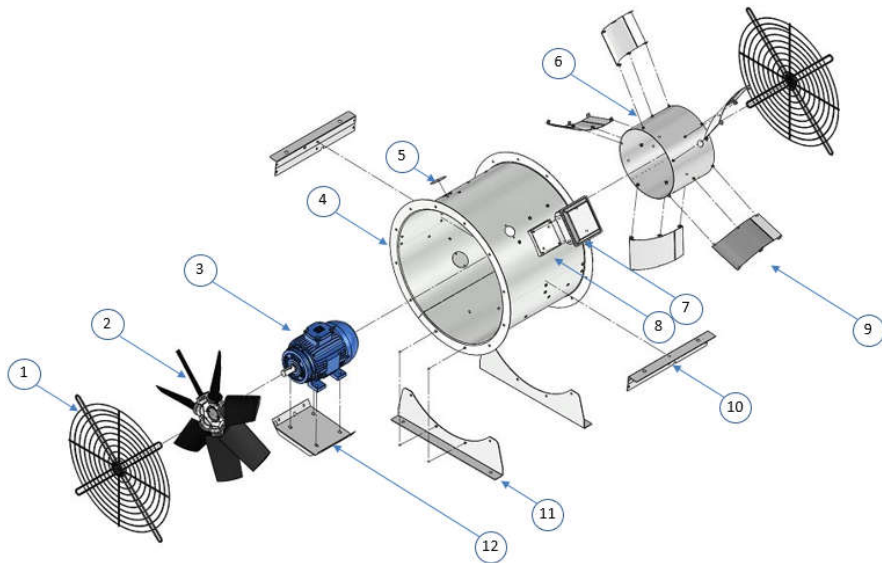

Fig. 10-1 Exploded view of version 4 fan

With reference to Fig. 10-1, the correct dismantling sequence for version 4 fans is as follows:

- Protection Net (1);
- Impeller (2);
- Motor (3);
- Tube Casing (4);
- View Port (5);
- Motor cover (6);
- Terminal Box (7);
- Terminal Support (8);
- Outlet Vane (9);
- Hanger (10);
- Mounting Feet (11);
- Motor Base (12)

## 10.2 Version 1 and 9 axial fans

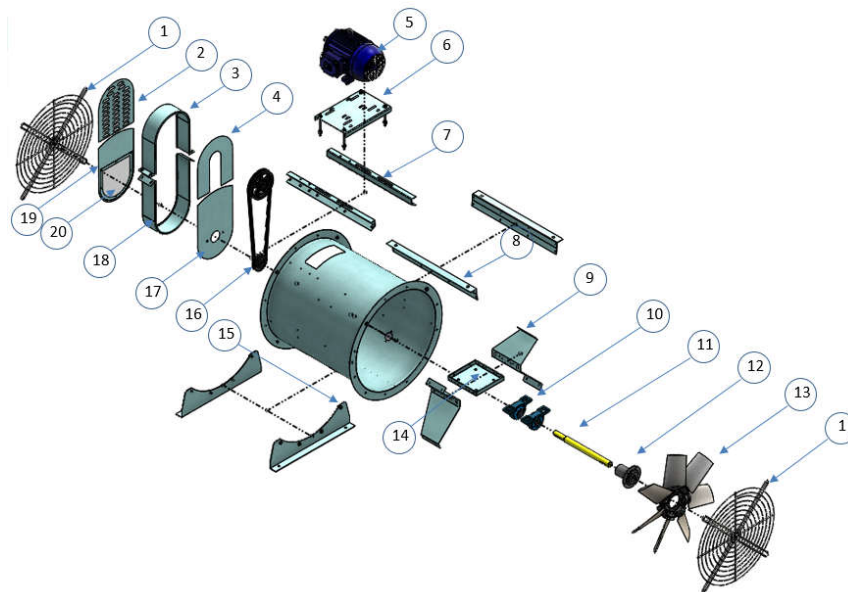

Fig. 10-2 Exploded view of version 1 and 9 fan

With reference to Fig. 10-2, the correct ducts sequence for version 1-9 fans is as follows:

- Protection Net (1);
- Upper Belt Back Cover (2);
- Upper Belt Casing (3);
- Upper Belt Front Cover (4);
- Motor (5);
- Motor Base (6);
- Lip Channel (7);
- Hanger Bar (8);
- Bearing Support (9);
- Bearing (10);
- Shaft (11);
- Hub (12);
- Impeller (13);
- Bearing Base (14);
- Mounting Feet (15);
- Drive Set (16);
- Lower Belt Back Cover (17);
- Lower Belt Casing (18);
- Lower Belt Front Cover (19);
- Access Door (20)

## 11 TECHNICAL APPENDICES

### 11.1 Tightening torques for nuts and bolts

Tightening torques M of the Table 11-1 are valid under the following conditions:

- Type UNI 5737 bolts with hexagonal heads, type UNI 5931 and UNI 6107 screws with cylindrical head, in normal conditions of supply.
- Tightening torques are assumed to be applied slowly with a torque wrench.

While maintaining the same pre-stressing values, tightening torques must be varied as follows in these cases:

- increased by 5% for UNI 5712 bolts with extra-wide heads
- reduced by 10% for oiled galvanized bolts
- reduced by 20% for oiled phosphate-treated bolts
- reduced by 10% if bolts are tightened with an impact wrench.

D x pitch			Sr mm <sup>2</sup>	8.8	10.9	12.9
mm				M Nm	M Nm	M Nm
6	x	1	20.1	10.4	15.3	17.9
7	x	1	28.9	17.2	25	30
8	x	1.25	36.6	25	37	44
10	x	1.5	58	50	73	86
12	x	1.75	84.3	86	127	148
14	x	2	115	137	201	235
16	x	2	157	214	314	368
18	x	2.5	192	306	435	509
20	x	2.5	245	432	615	719
22	x	2.5	303	592	843	987
24	x	3	353	744	1060	1240
27	x	3	459	1100	1570	1840
30	x	3.5	561	1500	2130	2500

Table 11-1 Tightening torques M for bolts with ISO metric threads

<b>Tightening torques valid for fixing bolts with 12.9 resistance class for aluminium blade on fans with steel hub</b>		
<b>Bolt</b>	<b>Torque (Nm)</b>	Torque must be checked with a torque wrench. Do not use galvanized nuts or bolts.
M8	30	
M10	60	
M12	80	
M16	110	

Table 11-2 Tightening torques for blade fixing bolts on fans with steel hub

## 11.2 Checklist before starting fans

The checks listed below are necessary, but could be insufficient in environments with particular types of risk.

CHECKLIST BEFORE STARTING FANS		
CODE	SERIAL NUMBER	YEAR
Identify installation type in accordance with paragraph 3.1.		A <input type="checkbox"/> B <input type="checkbox"/> C <input type="checkbox"/> D <input type="checkbox"/>
Check compatibility of fan with type of application.		OK <input type="checkbox"/>
Check that the fan and motor name plate data are compatible with the data on the product traveller and finished goods card (if present).		OK <input type="checkbox"/>
Check the compatibility of the electrical data of the motor name plate with the electrical power supply (frequency, voltage, connections); for further checks consult the motor instruction manual.		OK <input type="checkbox"/>
Check the efficiency of any power switch installed for the electrical power supply to the motor and any auxiliary circuits (e.g. heaters).		OK <input type="checkbox"/>
Check for absence of foreign bodies inside fan.		OK <input type="checkbox"/>
Check for presence of all nuts, bolts and other fasteners envisaged.		OK <input type="checkbox"/>
Check tightness of nuts and bolts in accordance with Table 11-1 (impeller, supports, foundations, transmission if present).		OK <input type="checkbox"/>
Check for the efficiency of interblock on access door to room or on safety barriers (if necessary).		OK <input type="checkbox"/>
Check lubrication conditions of bearings (including motor bearings if these can be lubricated)		OK <input type="checkbox"/>
Check that all rotating parts can turn freely.		OK <input type="checkbox"/>
Check directions of fan rotation and fluid flow.		OK <input type="checkbox"/>
Check availability of safety procedure for access to fan.		OK <input type="checkbox"/>
Check that personnel have been instructed and trained.		OK <input type="checkbox"/>
Date:		
Signature:		



### 11.3 Programmed maintenance intervals

The intervals of time suggested constitute a working basis for the customer, who must according to circumstances make any modifications necessary for the specific operating conditions.

Programmed maintenance intervals according to intensity of use				
		Intensity of use		
		High	Medium	Low
<b>For all fans</b>				
1	Check perfect condition of all protection net and warning symbols. See paragraph 1.3 and 6.2.1	1 month	1 month	1 month
2	Check correct tightness of all nuts and bolts in accordance with Table 11-1, above all in presence of cyclical thermal gradients	1 month	3 months	6 months
3	Check that the impeller is free from defects due to wear and corrosion. See paragraphs 6.2.2 and 6.2.3	1 month	3 months	6 months
4	Check that impeller is clean	1 month	6 months	12 months
5	Check for absence of dangerous vibrations. See also paragraph 3.7.4	1 month	6 months	12 months
6	Check for absence of abnormal noise	1 month	6 months	12 months
7	Check for correct lubrication of motor bearings. See paragraph 8.1	1 month	6 months	12 months
8	Check electrical operating parameters of motor and servomotors installed	1 month	6 months	12 months
9	Check perfect condition of all accessories installed	1 month	6 months	12 months
<b>Additional maintenance for fans with belt-drive transmission</b>				
10	Check tension and wear of drive belts. See paragraph 8.2	1 month	3 months	6 months
11	Check condition of lubrication of bearings in accordance with paragraph 8.1	See also transmission information card		
12	Check temperature of bearings. After an initial increase due to running in, temperature values should remain constant over time.	1 month	3 months	6 months

## 12 INDEX

- abrasion; 47
- accessories; 19; 22; 29; 30
- Sound; 8; 27; 28; 29
- air; 8; 17; 19; 22; 23; 24; 28; 44; 49; 50
- clean; 23; 24; 40; 56; 57; 69
- alignment; 38; 40; 59; 60; 61; 62
- angle; 41; 49; 56
- blade; 8; 26; 41; 47; 49; 56; 67
- assembly; 20; 21; 34; 36; 37; 38; 40; 41; 43; 56; 62; 63
- ATEX; 17; 22
- balance; 50
- base; 11; 12; 13; 14; 15; 16; 22; 30; 34; 36; 37; 38; 41; 56; 64; 65
- bearings; 18; 24; 27; 33; 40; 45; 46; 50; 53; 63; 68; 69
- belts; 18; 26; 38; 40; 46; 51; 54; 55; 56; 60; 61; 62; 63; 69
- tension; 40; 46; 50; 54; 55; 61; 69
- blades; 8; 26; 47
- bushes; 63
- casing; 11; 12; 13; 14; 15; 16; 17; 23; 24; 30; 36; 37; 43; 45; 47; 48; 63; 64; 65; 66
- chains; 30; 31; 32
- characteristics; 8; 17; 22; 24; 26; 27; 34; 42
- checks; 24; 40; 45; 46; 47; 48; 52; 68
- classification; 24
- cleaning; 24; 40; 47; 52; 54; 55; 56
- components; 11; 12; 13; 14; 15; 16; 18; 22; 23; 24; 25; 27; 30; 31; 32; 36; 37; 38; 42; 44; 46; 47; 48; 51; 56; 63
- connection; 19; 20; 21; 23; 26; 31; 32; 42; 43; 44; 45; 63; 68
- connector; 42
- grounding; 23; 42
- control; 22; 25; 42; 56
- corrosion; 46; 47; 69
- coupling; 49; 50; 51
- couplings; 8; 26
- flexible; 8; 21; 34; 44; 46; 48; 51; 63
- cycle; 24; 25
- diameter; 36; 37; 54; 60
- directives; 51
- dismantling; 56; 61; 63; 64
- ducts; 17; 19; 20; 21; 24; 34; 44; 48; 51; 55; 63; 65
- duration; 18
- dust; 17; 21; 24; 33; 47; 55
- efficiency; 8; 20; 22; 68
- energy; 8; 17
- emissions; 27; 28
- environment; 19; 22; 23; 24; 27; 28; 29; 33; 47; 55; 56; 63; 68
- equipment; 22; 28; 30; 31; 32; 34; 35; 51; 56; 63
- outlet; 12; 14; 16; 19; 20; 21; 23; 28; 29; 33; 34; 44; 52; 64
- explosion; 17; 22
- fixing; 20; 22; 23; 25; 34; 36; 37; 38; 46; 57; 67
- flange; 63
- flow; 8; 9; 17; 19; 35; 44; 49; 68
- hot; 7; 23; 51
- friction; 49; 50; 60
- gaskets; 44
- grease; 45; 52; 53; 63
- protection net; 7; 11; 12; 13; 15; 16; 18; 19; 20; 21; 22; 23; 24; 37; 38; 45; 46; 47; 63; 64; 65; 69
- holes; 30; 31; 32; 40; 50; 57; 60
- hub; 13; 14; 15; 26; 56; 65; 67
- name plate; 8; 10; 17; 22; 35; 42; 44; 45; 46; 49; 53; 55; 68
- inspection; 7; 24; 51
- installation; 6; 17; 19; 20; 21; 22; 23; 24; 25; 27; 28; 29; 34; 35; 38; 39; 41; 42; 44; 46; 49; 63; 68
- inlet; 16; 17; 19; 20; 21; 23; 28; 33; 34; 35; 44; 48; 49; 52; 63
- inverter; 25; 26; 49; 50
- lifting lugs; 32; 39
- load; 20; 21; 30; 31; 32; 33; 34; 54
- lubrication; 24; 45; 51; 52; 53; 68; 69
- interval; 18; 20; 53; 69
- maintenance; 18; 20; 24; 35; 42; 45; 51; 52; 56; 69
- materials; 17; 63
- life cycle; 18; 63

misalignment; 21; 34; 59  
 motor pedestal; 63  
 electric; 8; 17; 42; 63  
 movement; 17; 19; 21; 30; 31; 32; 33; 47; 51  
 multi-stage; 51  
 noise/noisiness; 8; 25; 27; 28; 29; 46; 50; 60; 69  
 nuts and bolts; 20; 25; 34; 46; 66; 68; 69  
 nuts; 22; 23; 36; 45; 68  
 oil; 23; 66  
 operation; 8; 17; 18; 20; 22; 23; 24; 25; 26; 27; 28; 30;  
 31; 32; 33; 34; 35; 36; 37; 38; 46; 47; 49; 50; 51; 52;  
 55; 56; 58; 61; 62; 63  
 paint/painting; 17; 48  
 parts; 7; 19; 20; 22; 23; 24; 25; 26; 30; 31; 34; 37; 38;  
 40; 43; 44; 45; 47; 49; 50; 51; 55; 56; 63; 68  
 lifting equipment; 30; 31; 32; 51  
 personal protective equipment (PPE); 22  
 play; 36; 37  
 positions; 9; 20; 22; 23; 26; 27; 28; 31; 32; 34; 35; 36;  
 37; 38; 39; 40; 43; 49; 59  
 power supply; 24; 42; 45; 46; 49; 50; 51; 56; 63; 68  
 voltage; 24; 42; 43; 49; 68  
 power; 8; 24; 26; 28; 42; 45; 46; 49; 56; 60; 68  
 absorbed; 8  
 installed; 8; 19; 21; 22; 23; 27; 35; 42; 44; 55; 68; 69  
 pressure; 8; 17; 21; 28; 29; 49  
 atmospheric; 17; 33  
 dynamic; 8; 17; 21; 34  
 resistance; 8; 49; 67  
 static; 8; 23; 27; 34  
 pre-tension; 55  
 pulleys; 26; 38; 40; 51; 56; 59; 60; 61; 63  
 qualified personnel; 30; 34; 35; 42  
 range; 17; 26  
 reassembly; 56  
 reliability; 18; 51  
 removal; 17; 20; 22; 23  
 risks; 6; 17; 19; 20; 22; 23; 24; 25; 27; 28  
 rotation direction; 26; 42; 45  
 rotation; 8; 17; 18; 24; 25; 26; 27; 28; 42; 45; 49; 53;  
 68  
 direction; 8; 17; 26; 46; 49; 68  
 safety; 6; 7; 18; 19; 20; 22; 24; 25; 32; 42; 45; 46; 47;  
 51; 68  
 screws; 40; 57; 58; 59; 60; 66  
 serial number; 21; 55; 68  
 series; 11; 12; 13; 14; 15; 16; 19; 41  
 shaft; 15; 16; 23; 25; 27; 31; 36; 37; 40; 56; 57; 58; 65  
 slipping; 55  
 spline; 57; 58  
 standards; 24; 27; 51  
 steel; 8; 17; 63; 67  
 stainless steel; 26; 27  
 supports; 34; 45; 46; 63; 68  
 surfaces; 7; 8; 23; 46; 48; 51  
 symbols; 6; 7; 22; 30; 31; 69  
 system; 8; 17; 19; 21; 23; 24; 25; 26; 27; 28; 29; 31; 34; 42;  
 49; 62  
 temperature; 11; 20; 21; 23; 24; 25; 27; 46; 51; 55; 69  
 high; 18; 20; 21; 23; 24; 26; 43; 49; 50; 51; 69  
 thickness; 47; 48  
 tightening torques; 60; 66; 67  
 tightening; 25; 34; 36; 37; 38; 40; 57  
 tools; 51; 61  
 transport; 17; 30; 33; 51; 63  
 intended; 6; 19; 22; 23; 45; 49  
 washer; 34; 37  
 spring; 34  
 wear; 18; 20; 24; 31; 47; 48; 49; 51; 55; 60; 69  
 welds; 46