

Wall Mount Type

Kitchen Fan

New Features for Filter Series



1 Perforated Aluminum Filter - Durable

The filter adopts aluminum material to assure excellent durability, and it is easy detachable for cleaning and maintenance.

2 Oil Collecting - Environmental Friendly

The perforated filter is competent in collecting oil. It allows the air exhausted to outdoor is less polluted that improves the air quality of surrounding.

3 Easy Clean Coating - Convenient

The perforated aluminum filter is processed with an easy-clean coating name "Hydrophobic Coating". It is basically a paint composed of fluorine compound particles that have small affinity with water or oil. This material has low surface tension allowing oil droplets falling on without adhering to the material.

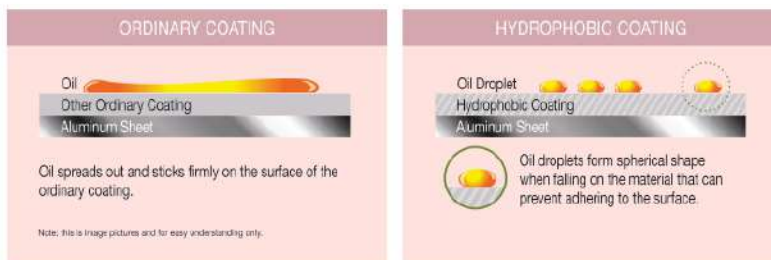

FV-25FUT1 Filter Series

- Recommend to use in kitchen
- Automatic Shutter
- Perforated aluminum filter
- Large capacity oil cup
- Oil Indicator on oil cup
- High exhaust air volume under actual usage condition (20Pa)

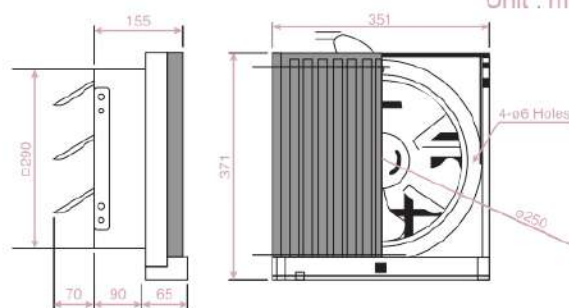

Dimension Unit : mm

Specification

Model	Air Volume		Input (W)	Speed (rpm)	Noise (dB(A))	Weight (Kg.)	Grill Size W x L (mm.)	Installation Space W x L (mm.)
	CMH	CFM						
FV-25FUT1	835	491	34	1,100	42	2.8	351 x 371	300 x 300

Note: The value in Specification tables are representative characteristic value at 220V, 50Hz. R.P.M. data is for reference only, values may vary subject to different conditions. The noise level is measured at 1 meter from fan.