



KRUGER

ASA

SINGLE INLET
CENTRIFUGAL FAN
with Airfoil Wheels

The logo consists of the word "KRUGER" in white, uppercase, sans-serif font, centered within a solid red square.

ASA Series

SINGLE INLET CENTRIFUGAL FAN with Airfoil Wheels



Kruger Ventilation Industries Asia Co.,Ltd certifies that the **ASA series** shown herein is licensed to bear the AMCA Seal. The ratings shown are based on tests and procedures performed in accordance with AMCA publication 211 and comply with the requirements of the AMCA Certified Ratings Program.



ASA Series Single Inlet Centrifugal Fans – Airfoil wheels

The ASA series is SISW centrifugal fans with high efficiency non-overloading airfoil impellers. The fans are suitable for supply or exhaust applications in commercial, process and industrial HVAC systems. Sizes of this series are in accordance with AMCA standard 99-0098-76 R20.

Type / Operating Limit

Each fan type has its maximum operating speed and power due to its mechanical design.

The operating limit of different fan types of ASA series is set according to the requirement of class I, II and III limit as defined in AMCA standard 99-2408-69.

	Model 315 to 630	Model 710 to 1400
Type C-U	I	I
Type T-U	II	II
Type X-U	III	II
Type Z-U		III

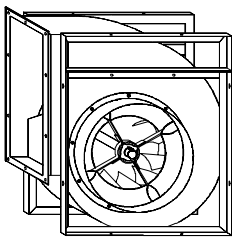

Type C

This type has a frame fitted on both sides of the fan which gives better strength and rigidity. It allows mounting in four different orientations.

Fan Size : 315 to 630
Volume : 1500 to 20000 m³/h
Total Pressure : up to 1800 Pa

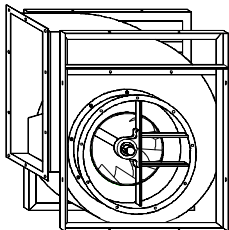

Type T

This type has a welded frame, giving increased stiffness and rigidity required for higher operating performance.

Fan Size : 315 to 1400
Volume : 1500 to 100000 m³/h
Total Pressure : up to 3000 Pa

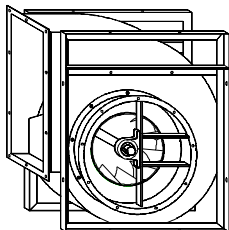

This structure is similar to Type T but utilizes enhanced bearings to support higher dynamic load necessary for the increased performance.

Fan Size : 315 to 1400
Volume : 1500 to 100000 m³/h
Total Pressure: up to 5000 Pa

Type Z is non-standard, for more information, please consult your nearest Kruger office for

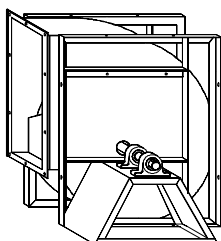

Type U

This type is manufactured with a special frame with two bearings fixed externally to the airflow eliminating any obstruction to the inlet and allow operation with air temperature up to max. of 180°C

Fan Size : 315 to 1400
Volume : 1500 to 100000 m³/h
Total Pressure : up to 5000 Pa

TECHNICAL SPECIFICATION

Wheel

The wheel of ASA is made of cold rolled sheet steel airfoil profile blades with polyester powder coating finish.

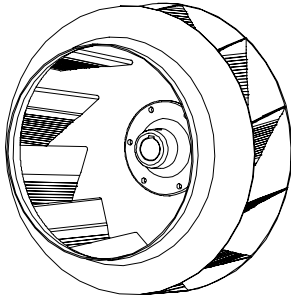

Housing

For all sizes except 1250 and above, the housing is manufactured in galvanized sheet steel with the housing fixed to the side plates in "pittsburg lock" form system.

Housing for 1250 and 1400 are manufactured in mild steel finished with polyester powder coating.

Fully welded steel plate housings with painted finish are available for all sizes upon request.

Frame

The frame is manufactured with galvanized angular bars for type "C". For type "T", "X" and "U", they are manufactured with sections of steel and finished with polyester powder coating.

Shaft

Shafts are manufactured from C45 carbon steel using an automatic process for positioning and cutting of the keyways. All dimensional tolerances of the shaft are fully checked to ensure a precision fit. All shaft are then coated with anti-corrosion varnish after assembly.

Bearings

Bearings used are either deep groove ball bearing type with an adapter sleeve, or spherical roller bearings type sealed at both sides for different duty application and are classified as below:

	Mounted in a rubber housing	Mounted on cast iron supports with grease point		
Fan Type	C 	T 	X 	U
Bearing Duty	CM Medium Duty 	TM Medium Duty 	XM Medium Duty 	UM Medium Duty
	eg. Model: ASA 450 C M 	TX Extra Heavy Duty 	XX Extra Heavy Duty 	UX Extra Heavy Duty

Except TX, XX, UX extra heavy duty, all bearings are lubricated for life and maintenance-free. If re-lubrication is necessary, it is recommended to use a lithium base grease suitable for all temperatures within the operational limits.

Balancing Quality

All wheels are statically and dynamically balanced to ISO1940 and AMCA 204 – G2.5 standards.

All fans after assembly are trim-balanced to ISO1940 and AMCA 204 - G2.5 standard.

Clean room application fans with balancing grade of G1.0 are available upon request.

ACCESSORIES

Casing Drain

This option is available when using fans exposed to the atmosphere or operating in high humidity conditions.

Outlet Flanges

Outlet flanges are available upon request.

Inlet Flanges

This option is set against the fan to facilitate installation. It is available in 2 types-“L” flange or “U” flange.

Inspection Doors

The inspection door can be supplied upon request. It can be supplied in one of the three positions (P3, P4 & P5).

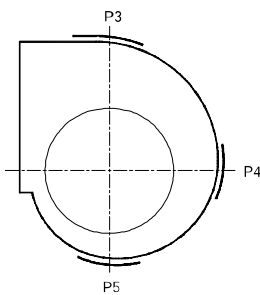

Guards

Inlet guard, discharge guards and non-drive end shaft guards are available on request.

Fan Rotation and Discharge

The rotation and discharge of the fan is in accordance with AMCA standard 99-2406-83.

The direction of rotation is determined from the drive side of the fan :-

CW - clockwise rotation

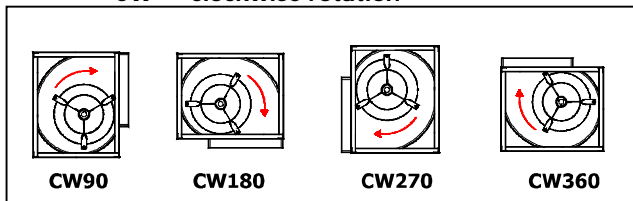

CCW - counter-clockwise rotation

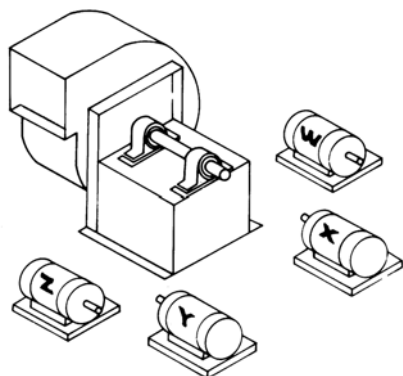
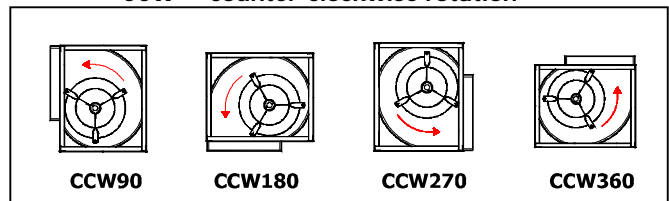

Motor Position

The position of the motor for belt drive centrifugal fan is in accordance with AMCA standard 99-2407-66.

Location of motor is determined by facing the drive side of fan and designating the positions by letters W, X, Y, or Z.

Reprinted from AMCA Standard 99-2407-03, Motor Positions for Belt Chain Drive Centrifugal Fans, with the express written permission from the Air Movement and Control Association International, Inc., 30 West University Drive, Arlington Heights, IL 60004-1983.

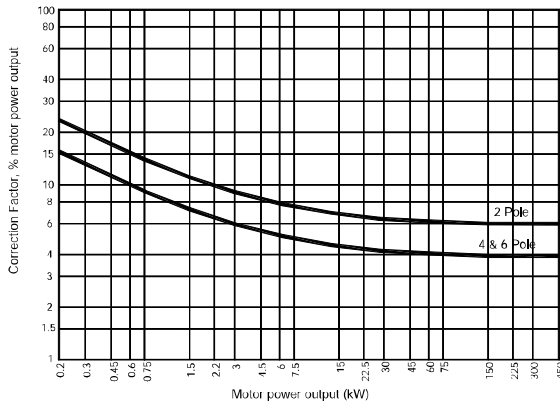

Motor Selection

The power curve shown on each performance graph represents the absorbed power at the shaft of the fan measured in kW.

To determine the power of the motor to be installed, a correction factors should be applied to compensate for transmission losses.

For conversion to horsepower (HP), use multiplying factor 1.34.

Dynamic Pressure

Both dynamic pressure and outlet air velocity shown on each graph are calculated base on the full air discharge area, i.e. ducted outlet conditions.

With free outlet conditions the velocity pressure is higher. To determine this new value, multiply the velocity pressure of the ducted outlet obtained from the fan curve by the following correction factor "K".

$$K = 1.67$$

Fan performances calculated with this correction factors are not licensed by AMCA.

Performance

The performance data shown on each graph is derived from tests conducted in accordance to AMCA Standard 210 – Fig 12 – installation type B (free inlet and ducted outlet condition).

Ratings refer to the standard air density with the total pressure as a function of the air volume, using logarithmic scales.

It is essential that the same installation type and test standards are used at all times when comparing fan performances.

Noise

The noise levels shown on each graph refer to the "A-weighted" sound power values and the data on the inlet side has been measured in accordance with AMCA Standard 300 diag. 2 - configuration "B". The noise levels of the fans are determined as follows:

- Sound power level - ("A" scale): Lw (A) as catalogue
- Octave band spectrum: Lw = Lw(A) + Lw rel. dB [refer to Kruger for more details]
- Sound pressure level:

a) free field

$$Lp(A) = Lw(A) - (20\log_{10}d) - 11$$

b) room conditions

$$Lp(A) = Lw(A) - (20\log_{10}d) - 8$$

where d = distance from fan (m)

Performance

The performance data shown on each diagram is derived from tests conducted in accordance to AMCA Standard 210- Fig 12- Installation type B (free inlet and duct outlet condition).

Ratings refer to standard air density with the total pressure as a function of the air volume, using logarithmic scale.

It is essential that the same installation type and test standards are used at all time when comparing fan performance.

According to AMCA 205, ASA series can be classify as FEG 80–85 based on fan peak efficiency. The following is the explanation of FEG classification:

1. Fan size is the impeller diameter in mm.
2. The fan peak efficiency shall be calculated from the fan (total) pressure.
3. If this method is used for a direct driven fan, the fan efficiency is the impeller efficiency.
4. The FEG label for a given fan size is assigned when the fan peak efficiency is equal to or lower than the efficiency at the grade upper limit, and higher than the efficiency at the grade upper limit of the next lower grade for the fan size.
5. For any fan sizes larger than 1016 mm, the values of the grade upper limits are the same as for a size of 1016 mm.
6. No labels are considered for the fans with the fan peak total efficiency below FEG 50.
7. The values of efficiencies are calculated for fan sizes in the preferred R40 Series.
8. Not all available fan sizes are shown.

Fan Efficiency Grades (FEG) for Fans without Drives (SI) – AMCA 205

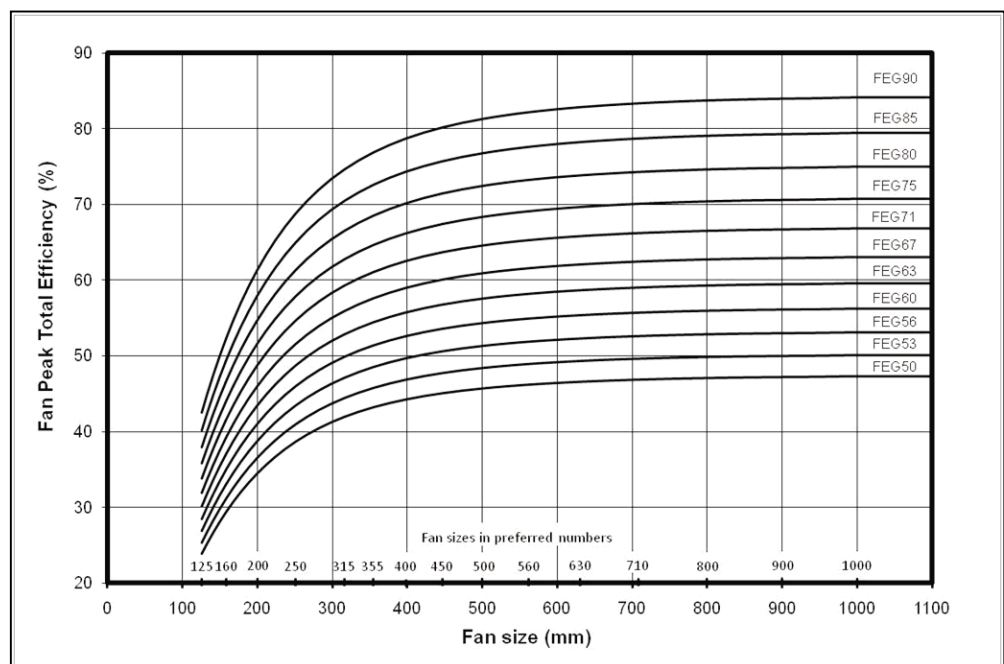



ASA 315

FEG 80

Op Limit	Cl. I	Cl. II	Cl. III
Type	C-U	T-U	X-U
M.kW	2	5	10
M.RPM	3350	4300	5400

$\gamma = 1.22 \text{ kg/m}^3$

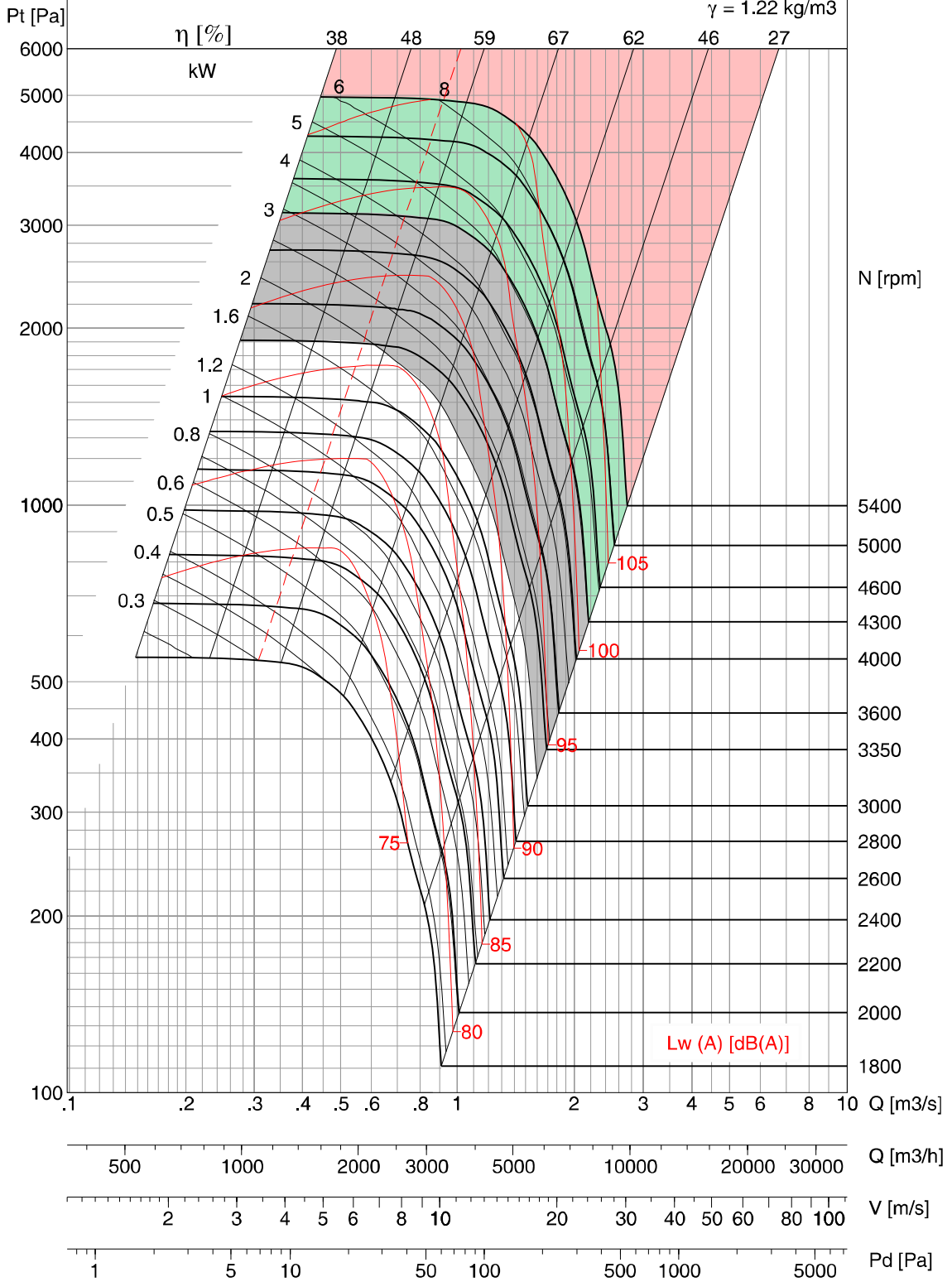

- Performance shown is for Installation type B - free inlet, ducted outlet. Performance ratings do not include the effects of appurtenances (accessories). Power rating kW does not include transmission losses.
 - Test A-weighted sound ratings shown have been calculated per AMCA standard 301. Values shown are for inlet Lw(A) sound power levels for installation type B - free inlet, ducted outlet. Rating do not include the effect of duct end corrections.
 - The AMCA Certified Ratings Seal applies to air performance rating only.



ASA 355

FEG 80

Op Limit	Cl. I	Cl. II	Cl. III
Type	C-U	T-U	X-U
M.kW	3	6	12
M.RPM	2800	3600	4550

$\gamma = 1.22 \text{ kg/m}^3$

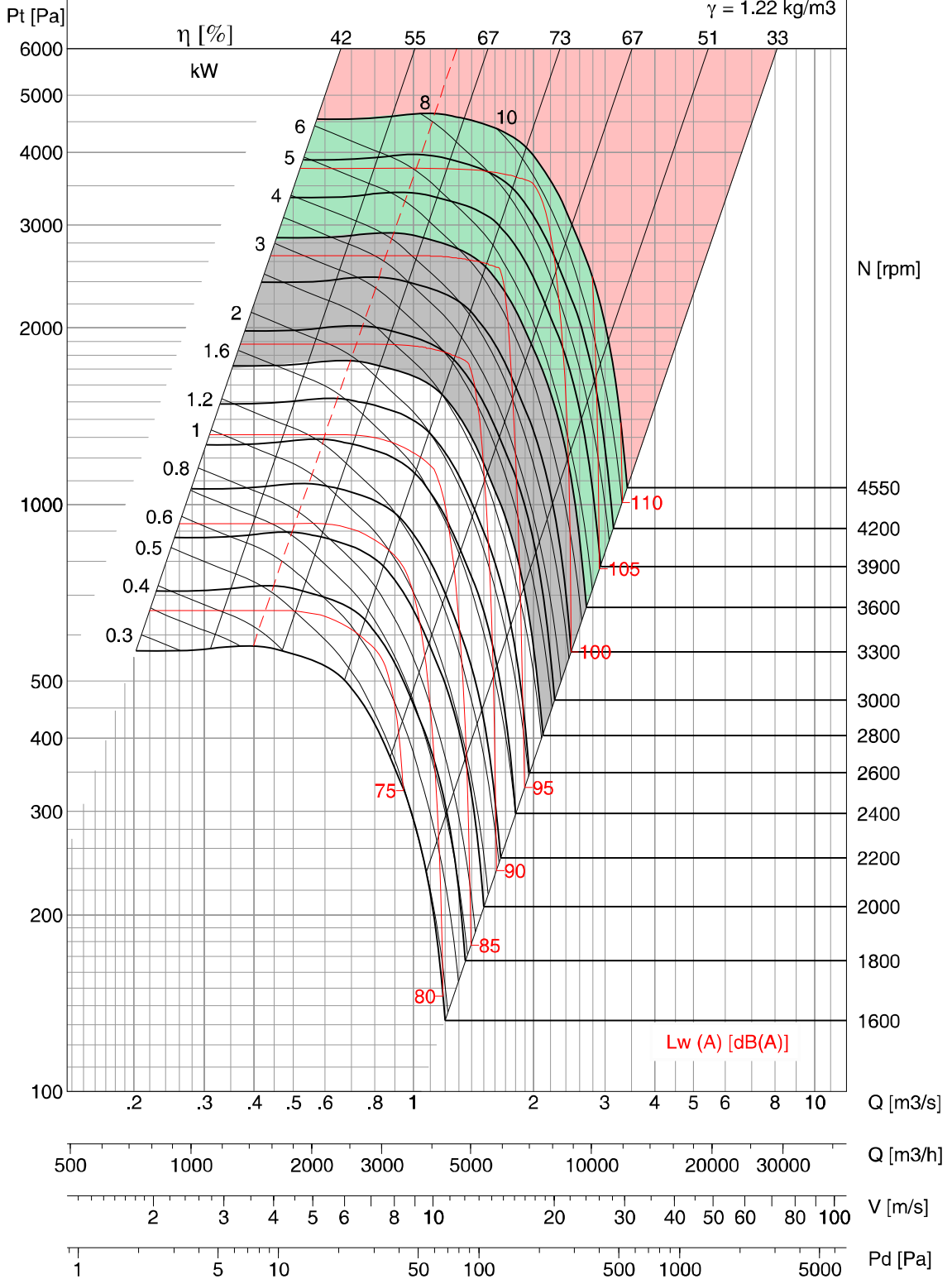

- Performance shown is for Installation type B - free inlet, ducted outlet. Performance ratings do not include the effects of appurtenances(accessories). Power rating kW does not include transmission losses.
 - Test A-weighted sound ratings shown have been calculated per AMCA standard 301. Values shown are for inlet Lwi(A) sound power levels for installation type B - free inlet, ducted outlet. Rating do not include the effect of duct end corrections.
 - The AMCA Certified Ratings Seal applies to air performance rating only.



ASA 400

FEG 85

Op Limit	Cl. I	Cl. II	Cl. III
Type	C-U	T-U	X-U
M.kW	3	7	14
M.RPM	2500	3250	4100

$\gamma = 1.22 \text{ kg/m}^3$

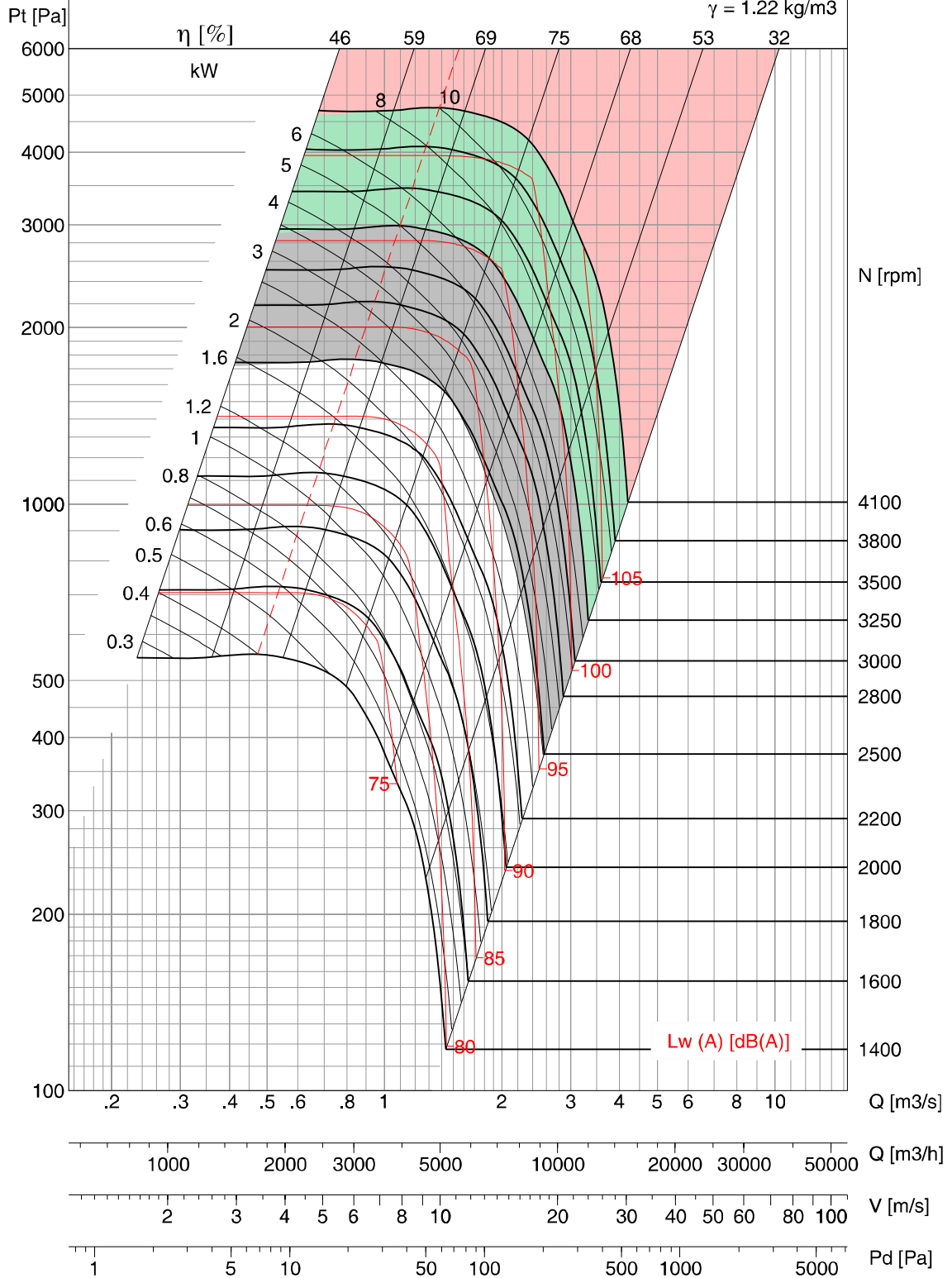

- Performance shown is for Installation type B - free inlet, ducted outlet. Performance ratings do not include the effects of appurtenances (accessories). Power rating kW does not include transmission losses.
 - Test A-weighted sound ratings shown have been calculated per AMCA standard 301. Values shown are for inlet Lw(A) sound power levels for installation type B - free inlet, ducted outlet. Rating do not include the effect of duct end corrections.
 - The AMCA Certified Ratings Seal applies to air performance rating only.



ASA 450

FEG 85

Op Limit	Cl. I	Cl. II	Cl. III
Type	C-U	T-U	X-U
M.kW	4	9	17
M.RPM	2200	2850	3600

$\gamma = 1.22 \text{ kg/m}^3$

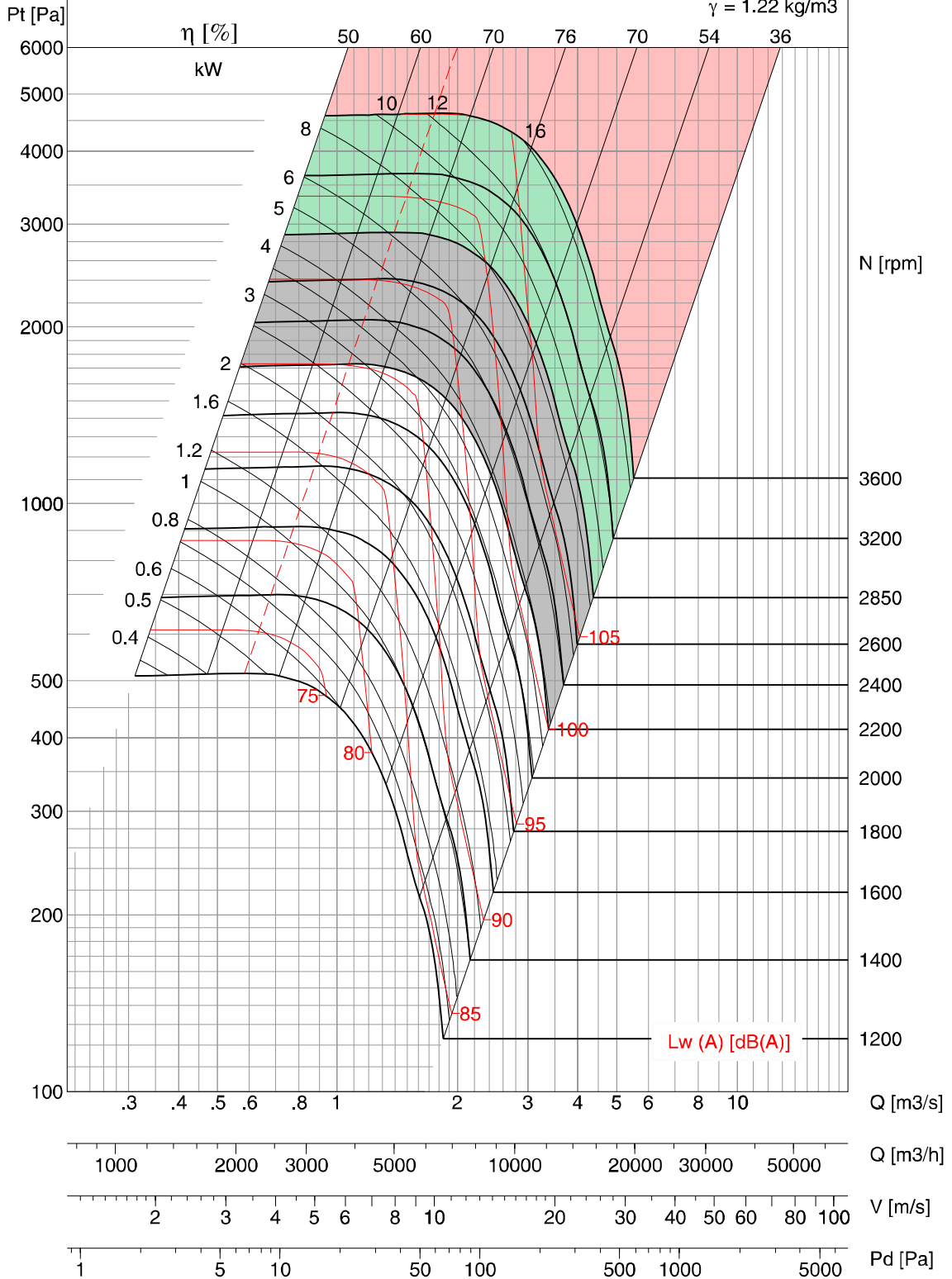

- Performance shown is for Installation type B - free inlet, ducted outlet. Performance ratings do not include the effects of appurtenances (accessories). Power rating kW does not include transmission losses.
 - Test A-weighted sound ratings shown have been calculated per AMCA standard 301. Values shown are for inlet Lw(A) sound power levels for installation type B - free inlet, ducted outlet. Rating do not include the effect of duct end corrections.
 - The AMCA Certified Ratings Seal applies to air performance rating only.



ASA 500

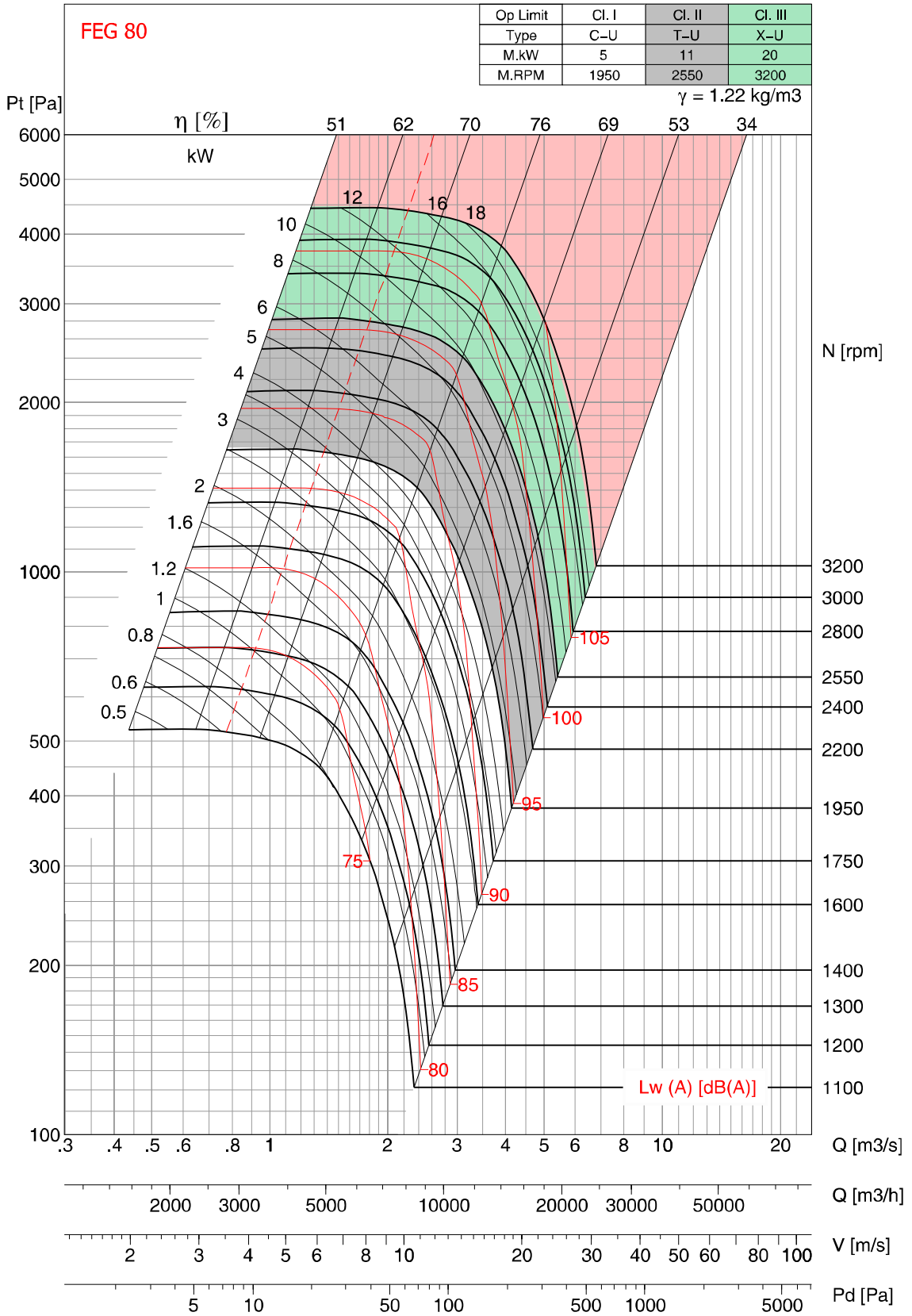

- Performance shown is for Installation type B - free inlet, ducted outlet. Performance ratings do not include the effects of appurtenances (accessories). Power rating kW does not include transmission losses.
- Test A-weighted sound ratings shown have been calculated per AMCA standard 301. Values shown are for inlet Lw(A) sound power levels for installation type B - free inlet, ducted outlet. Rating do not include the effect of duct end corrections.
- The AMCA Certified Ratings Seal applies to air performance rating only.



ASA 560

FEG 80

Op Limit	Cl. I	Cl. II	Cl. III
Type	C-U	T-U	X-U
M.kW	6	13	26
M.RPM	1700	2250	2800

$\gamma = 1.22 \text{ kg/m}^3$

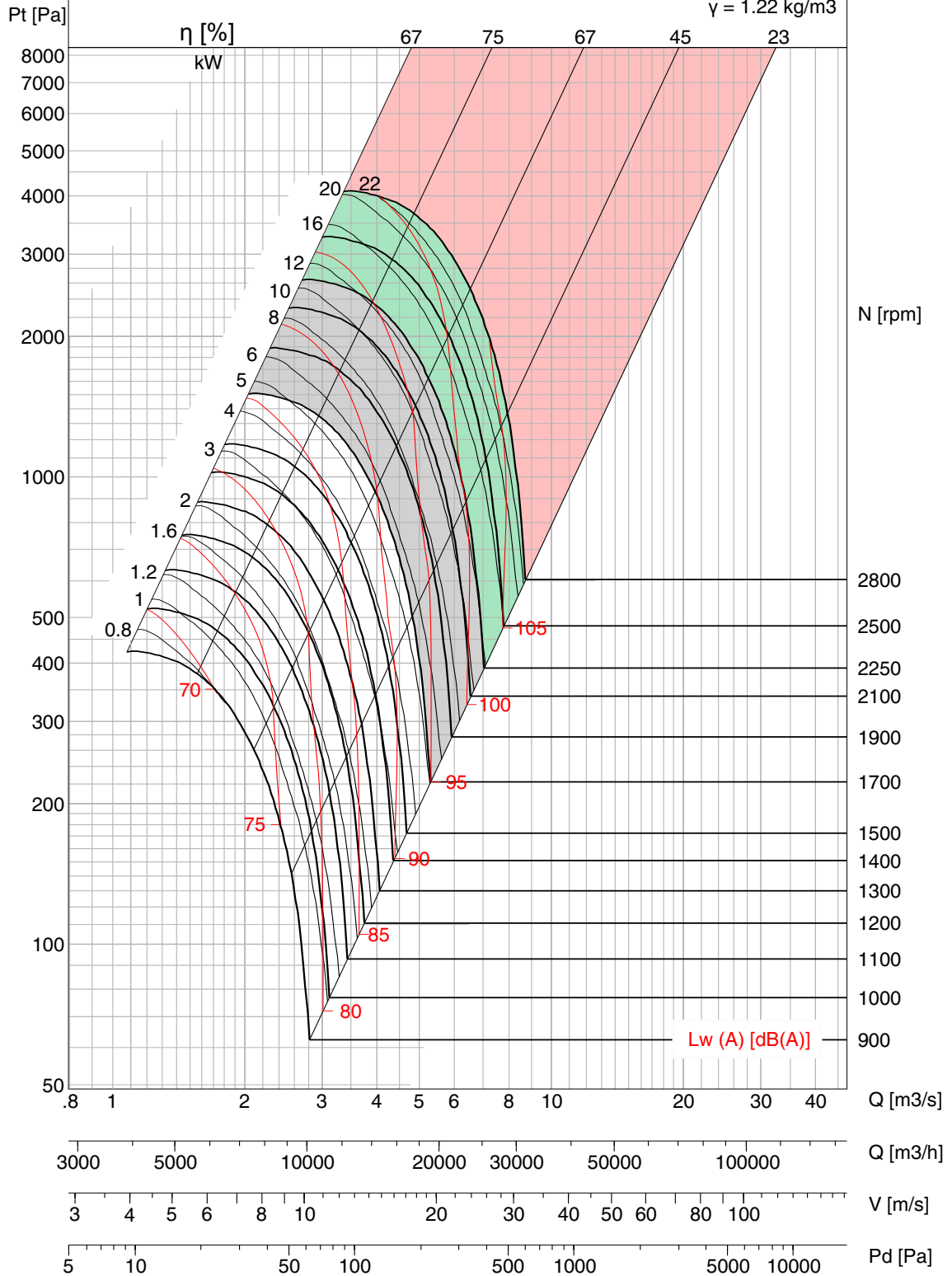

- Performance shown is for Installation type B - free inlet, ducted outlet. Performance ratings do not include the effects of appurtenances (accessories). Power rating kW does not include transmission losses.
- Test A-weighted sound ratings shown have been calculated per AMCA standard 301. Values shown are for inlet Lw(A) sound power levels for installation type B - free inlet, ducted outlet. Rating do not include the effect of duct end corrections.
- The AMCA Certified Ratings Seal applies to air performance rating only.



ASA 630

FEG 80

Op Limit	Cl. I	Cl. II	Cl. III
Type	C-U	T-U	X-U
M.kW	8	16	32
M.RPM	1550	2000	2500

$\gamma = 1.22 \text{ kg/m}^3$

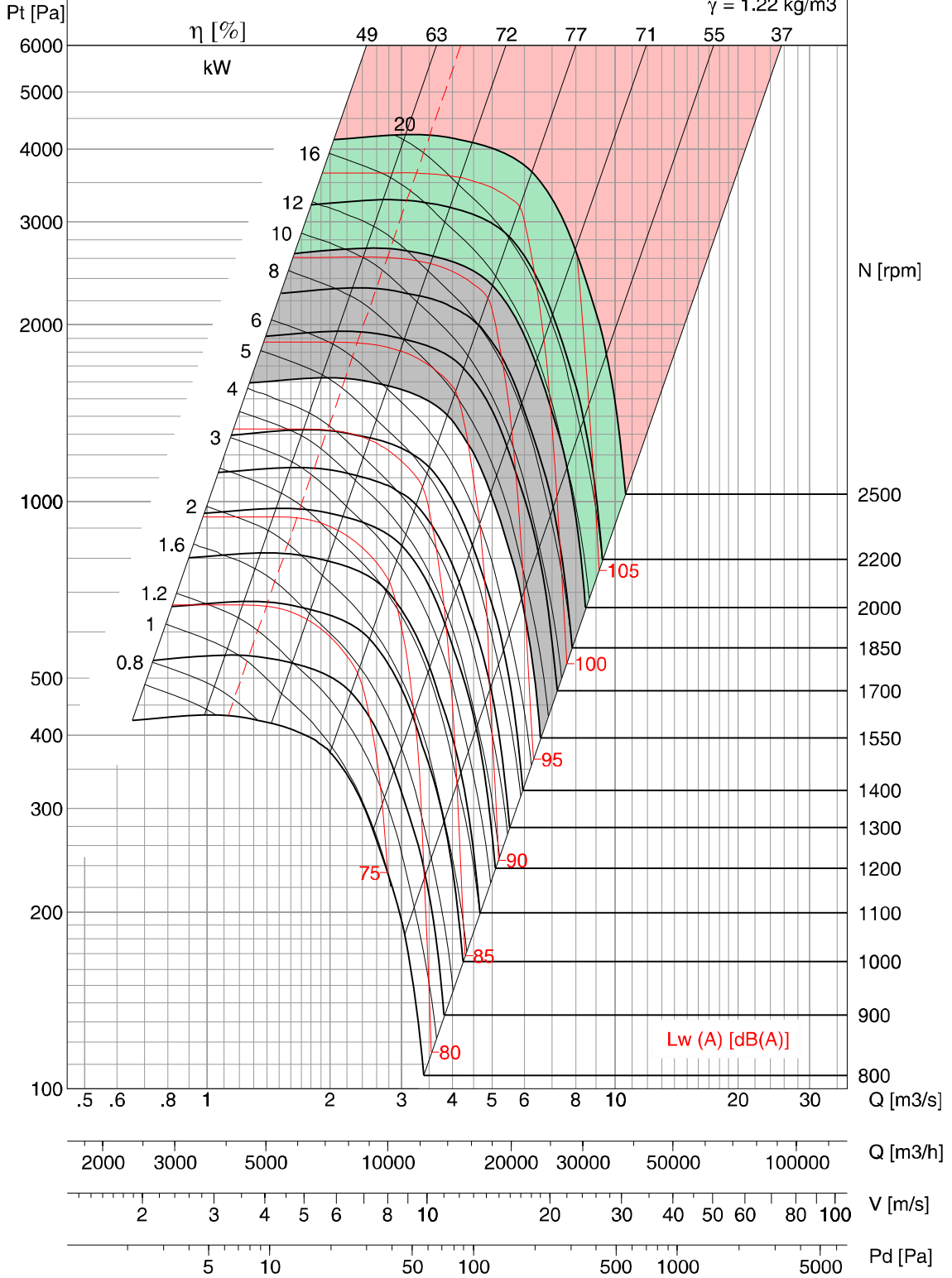

- Performance shown is for Installation type B - free inlet, ducted outlet. Performance ratings do not include the effects of appurtenances(accessories). Power rating kW does not include transmission losses.
- Test A-weighted sound ratings shown have been calculated per AMCA standard 301. Values shown are for inlet Lw(A) sound power levels for installation type B - free inlet, ducted outlet. Rating do not include the effect of duct end corrections.
- The AMCA Certified Ratings Seal applies to air performance rating only.



ASA 710

FEG 80

Op Limit	Cl. I	Cl. II	Cl. III
Type	T-U	X-U	Z-U
M.kW	10	20	40
M.RPM	1350	1750	2250

$\gamma = 1.22 \text{ kg/m}^3$

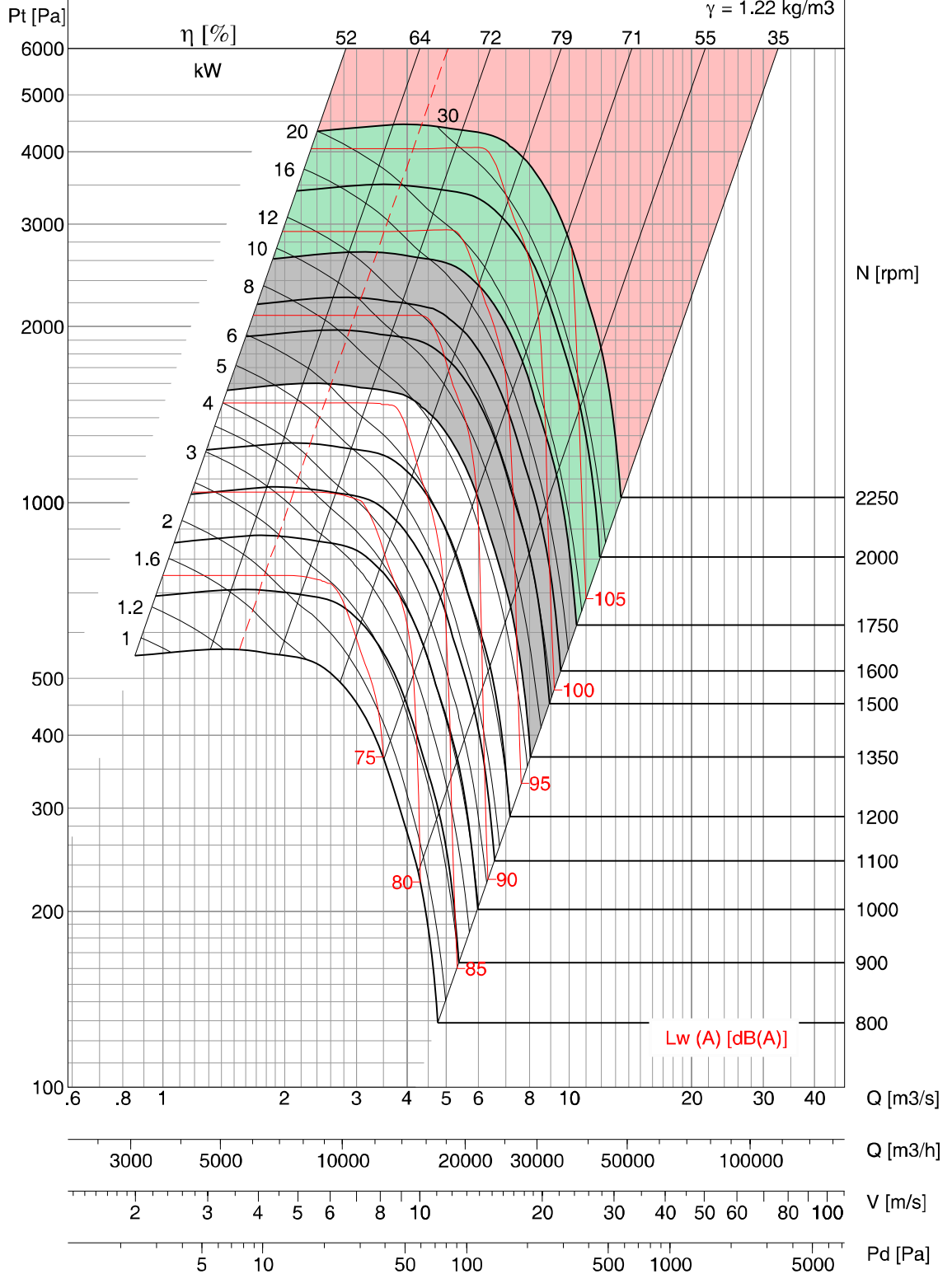

- Performance shown is for Installation type B - free inlet, ducted outlet. Performance ratings do not include the effects of appurtenances(accessories). Power rating kW does not include transmission losses.
- Test A-weighted sound ratings shown have been calculated per AMCA standard 301. Values shown are for inlet Lwi(A) sound power levels for installation type B - free inlet, ducted outlet. Rating do not include the effect of duct end corrections.
- The AMCA Certified Ratings Seal applies to air performance rating only.



ASA 800

FEG 80

Op Limit	Cl. I	Cl. II	Cl. III
Type	T-U	X-U	Z-U
M.kW	12	25	50
M.RPM	1200	1550	2000

$\gamma = 1.22 \text{ kg/m}^3$

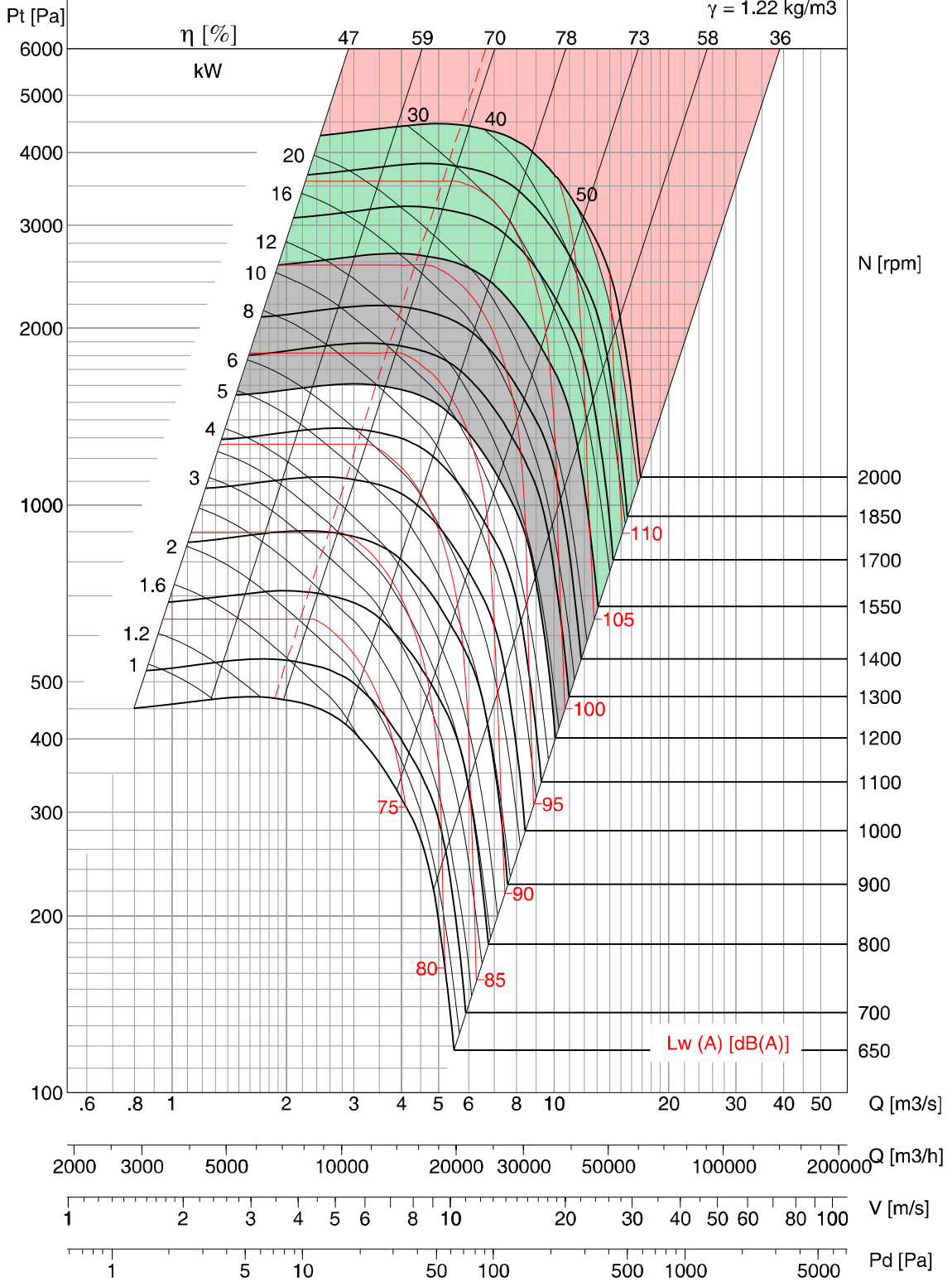

- Performance shown is for Installation type B - free inlet, ducted outlet. Performance ratings do not include the effects of appurtenances (accessories). Power rating kW does not include transmission losses.
 - Test A-weighted sound ratings shown have been calculated per AMCA standard 301. Values shown are for inlet Lw(A) sound power levels for installation type B - free inlet, ducted outlet. Rating do not include the effect of duct end corrections.
 - The AMCA Certified Ratings Seal applies to air performance rating only.



ASA 900

FEG 80

Op Limit	Cl. I	Cl. II	Cl. III
Type	T-U	X-U	Z-U
M.kW	15	32	65
M.RPM	1050	1400	1750

$\gamma = 1.22 \text{ kg/m}^3$

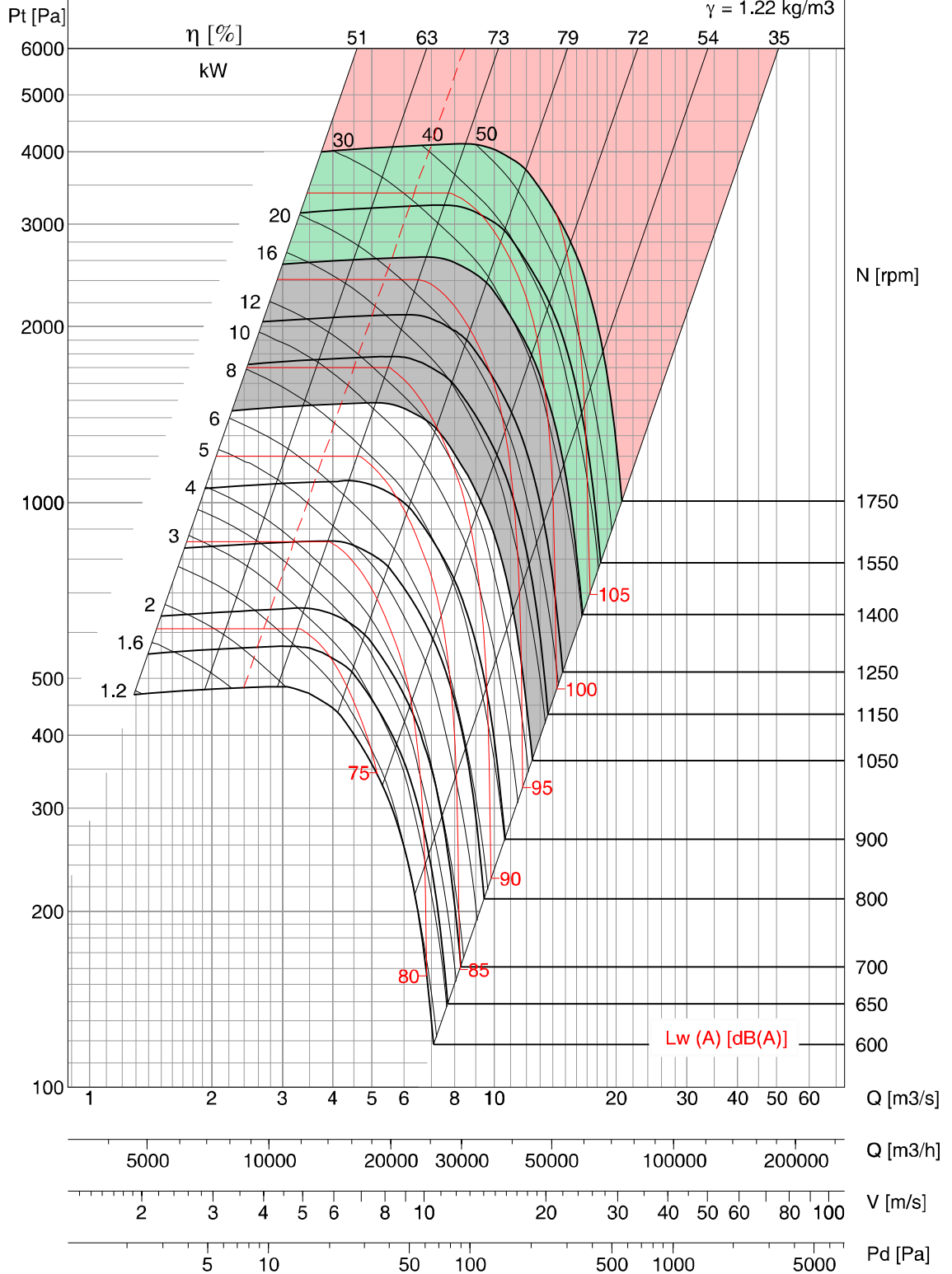

- Performance shown is for Installation type B - free inlet, ducted outlet. Performance ratings do not include the effects of appurtenances(accessories). Power rating kW does not include transmission losses.
- Test A-weighted sound ratings shown have been calculated per AMCA standard 301. Values shown are for inlet Lwi(A) sound power levels for installation type B - free inlet, ducted outlet. Rating do not include the effect of duct end corrections.
- The AMCA Certified Ratings Seal applies to air performance rating only.



ASA 1000

FEG 80

Op Limit	Cl. I	Cl. II	Cl. III
Type	T-U	X-U	Z-U
M.kW	18	40	80
M.RPM	950	1250	1600

$\gamma = 1.22 \text{ kg/m}^3$

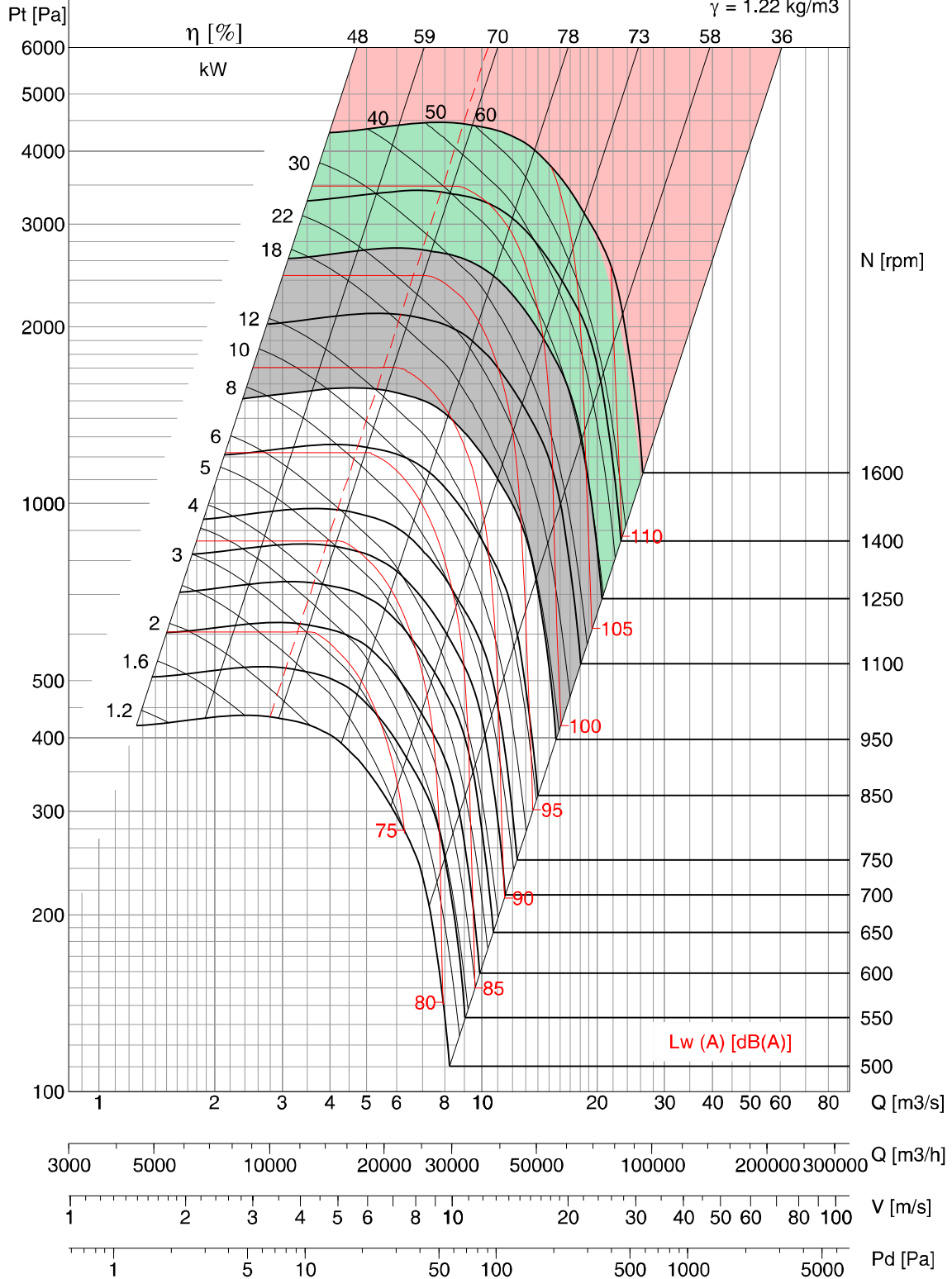

- Performance shown is for Installation type B - free inlet, ducted outlet. Performance ratings do not include the effects of appurtenances(accessories). Power rating kW does not include transmission losses.
- Test A-weighted sound ratings shown have been calculated per AMCA standard 301. Values shown are for inlet Lw(A) sound power levels for installation type B - free inlet, ducted outlet. Rating do not include the effect of duct end corrections.
- The AMCA Certified Ratings Seal applies to air performance rating only.



ASA 1120

FEG 80

Op Limit	Cl. I	Cl. II	Cl. III
Type	T-U	X-U	Z-U
M.kW	25	50	100
M.RPM	850	1100	1400

$\gamma = 1.22 \text{ kg/m}^3$

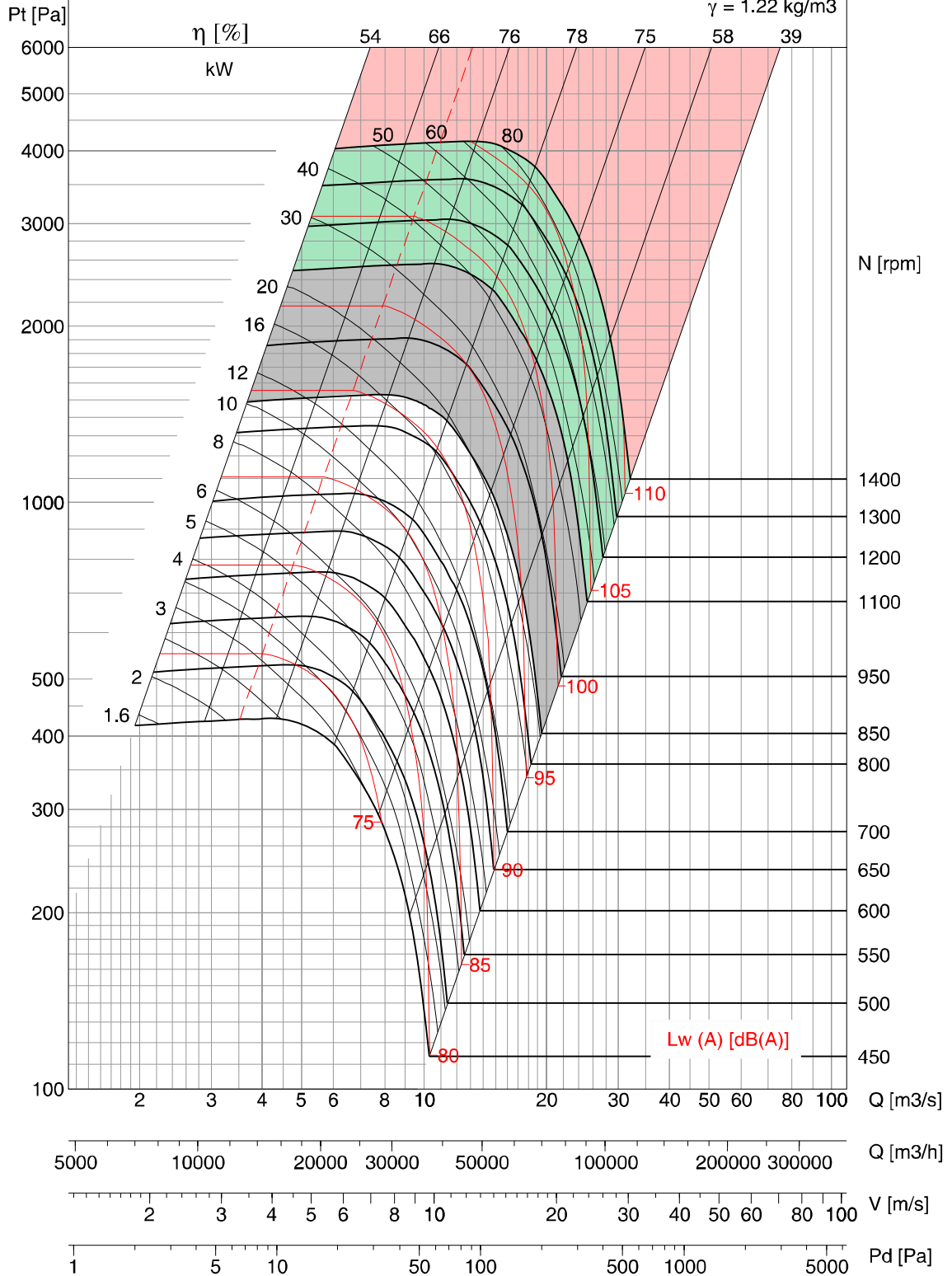

- Performance shown is for Installation type B - free inlet, ducted outlet. Performance ratings do not include the effects of appurtenances(accessories). Power rating kW does not include transmission losses.
- Test A-weighted sound ratings shown have been calculated per AMCA standard 301. Values shown are for inlet Lw(A) sound power levels for installation type B - free inlet, ducted outlet. Rating do not include the effect of duct end corrections.
- The AMCA Certified Ratings Seal applies to air performance rating only.



ASA 1250

FEG 80

Op Limit	Cl. I	Cl. II	Cl. III
Type	T-U	X-U	Z-U
M.kW	26	55	110
M.RPM	750	1000	1250

$\gamma = 1.22 \text{ kg/m}^3$

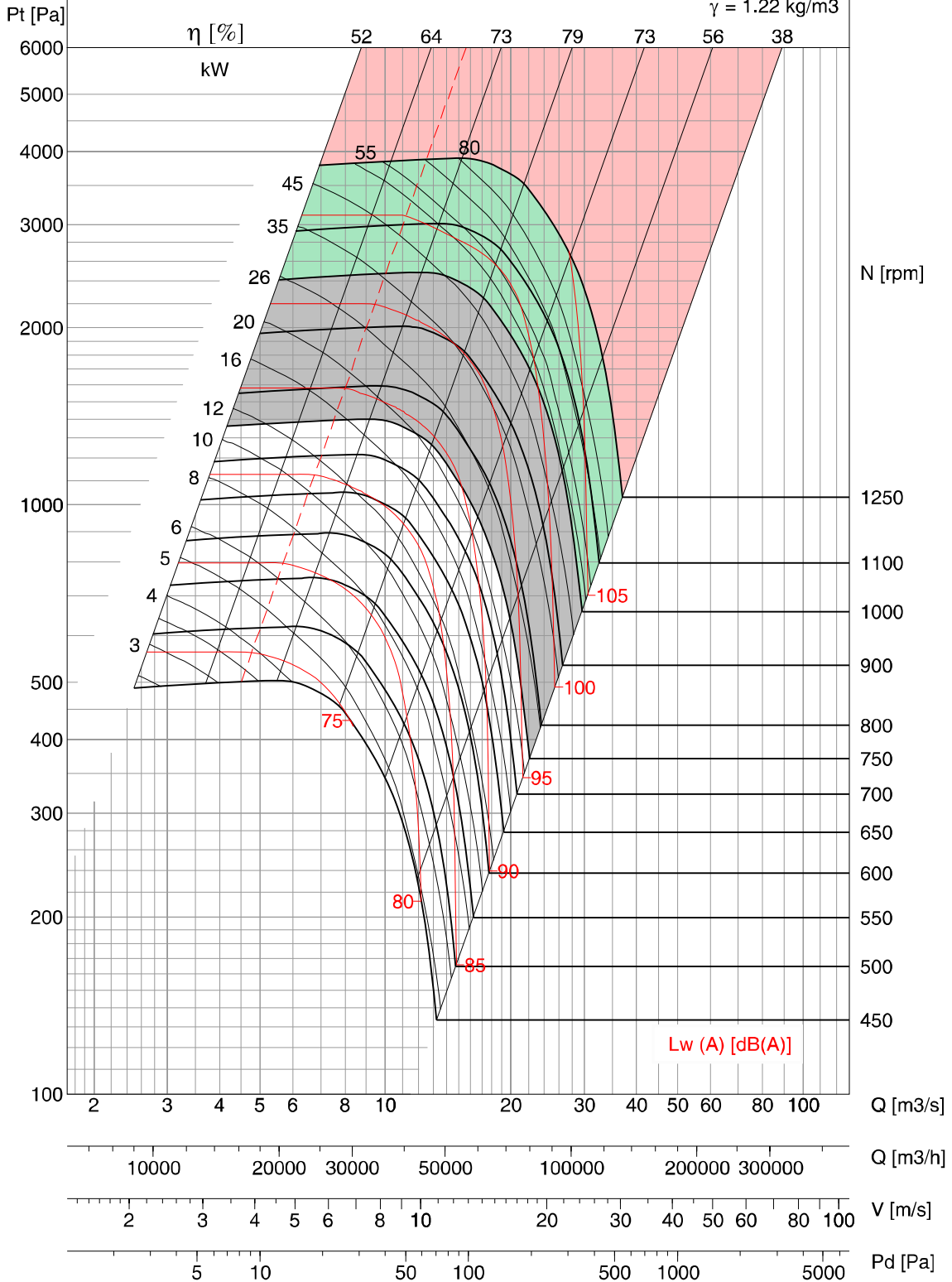

- Performance shown is for Installation type B - free inlet, ducted outlet. Performance ratings do not include the effects of appurtenances(accessories). Power rating kW does not include transmission losses.
- Test A-weighted sound ratings shown have been calculated per AMCA standard 301. Values shown are for inlet Lw(A) sound power levels for installation type B - free inlet, ducted outlet. Rating do not include the effect of duct end corrections.
- The AMCA Certified Ratings Seal applies to air performance rating only.



ASA 1400

FEG 80

Op Limit	Cl. I	Cl. II	Cl. III
Type	T-U	X-U	Z-U
M.kW	35	80	150
M.RPM	650	850	1100

$\gamma = 1.22 \text{ kg/m}^3$

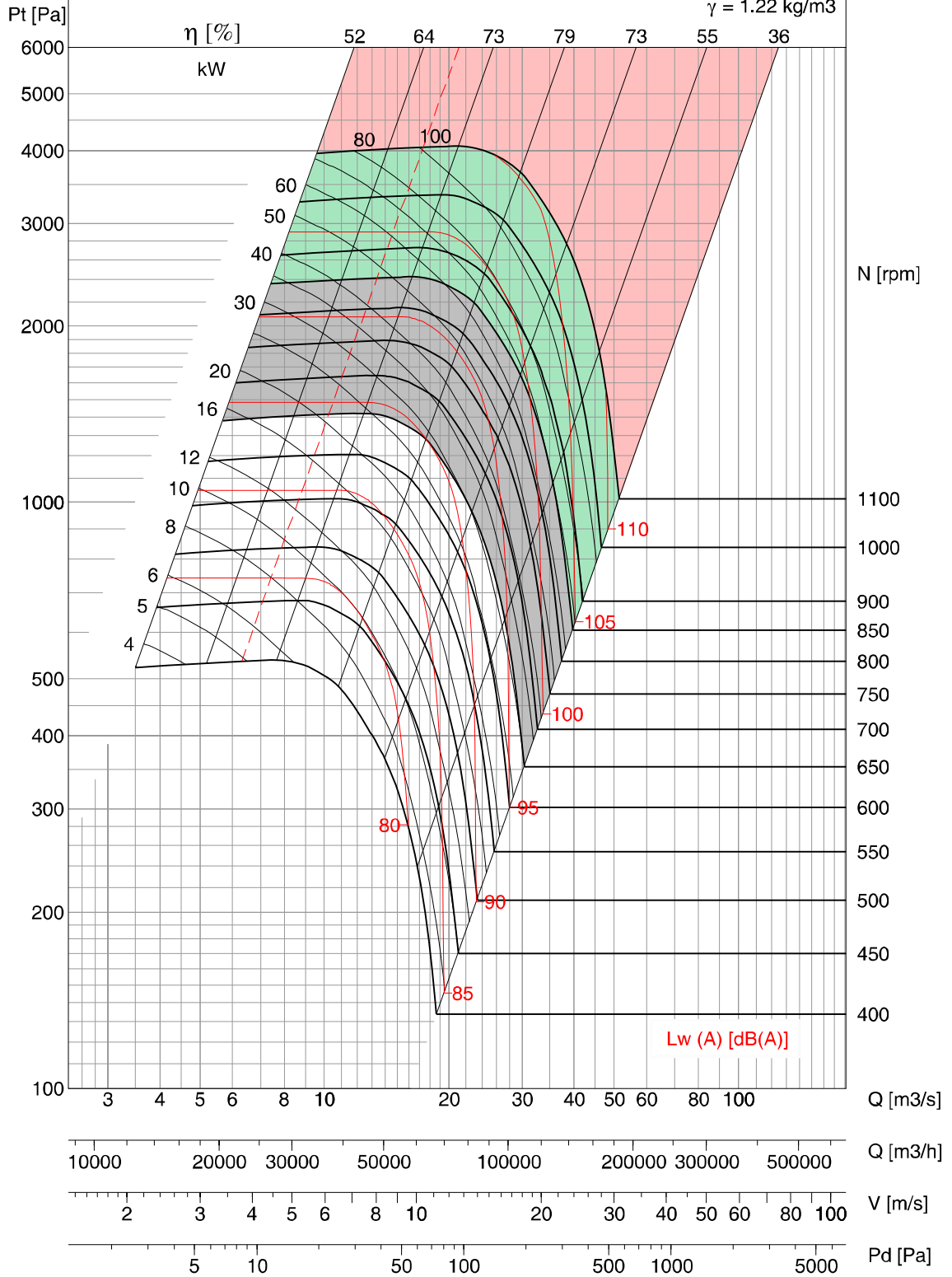

- Performance shown is for Installation type B - free inlet, ducted outlet. Performance ratings do not include the effects of appurtenances(accessories). Power rating kW does not include transmission losses.
- Test A-weighted sound ratings shown have been calculated per AMCA standard 301. Values shown are for inlet Lw(A) sound power levels for installation type B - free inlet, ducted outlet. Rating do not include the effect of duct end corrections.
- The AMCA Certified Ratings Seal applies to air performance rating only.

ASA 315-400 'C'

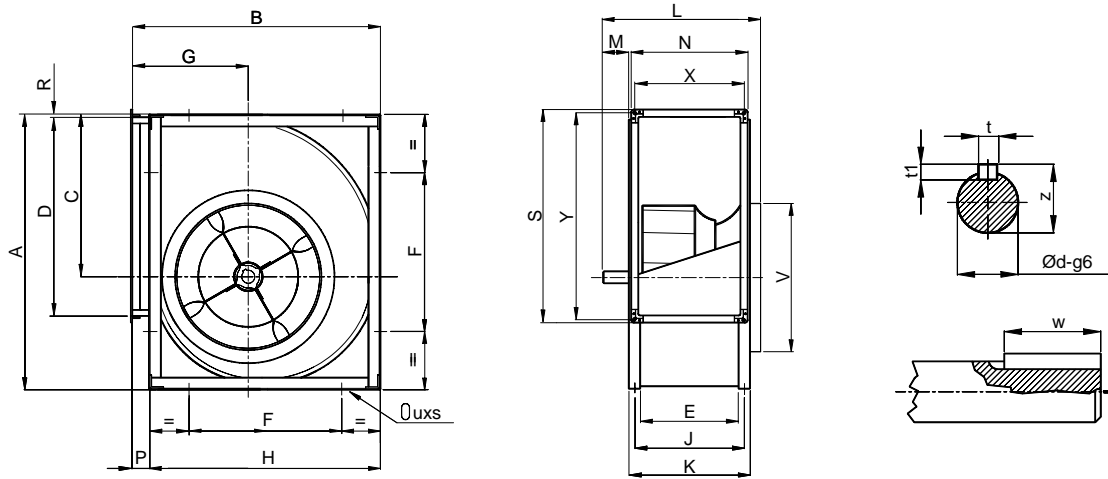

Model	A	B	C	D	E	F	G	H	J	K	L	M	N	P	R	S	V	X	Y	t	t1	w	z	Ød	UxS
315	578	518	340	404	223	330	236	480	253	283	451	78	279	38	3	460	319	251	432	8	7	40	28	25	13x18
355	654	578	383	452	247	368	260	548	287	327	479	72	303	30	6	508	359	275	480	8	7	40	33	30	13x18
400	736	650	432	506	274	402	290	612	314	354	506	72	330	38	5	562	404	302	534	8	7	40	33	30	13x18

All Dimensions in mm.

ASA 450-630 'C'

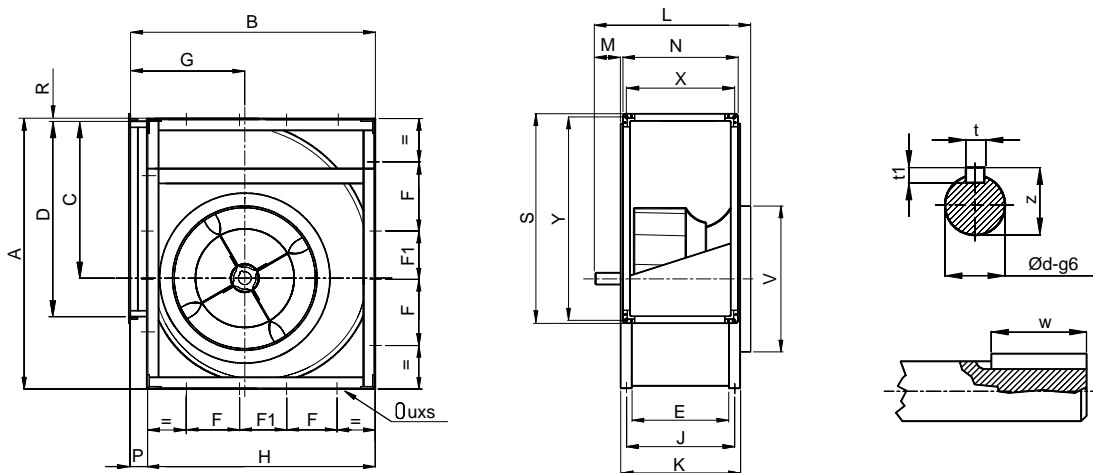

Model	A	B	C	D	E	F	F1	G	H	J	K	L	M	N	P	R	S	V	X	Y	t	t1	w	z	Ød	UxS
450	827	726	486	568	308	200	111	322	681	348	388	556	88	364	45	5	624	454	336	596	10	8	50	38	35	13x18
500	918	800	538	638	345	245	120	352	750	385	425	593	88	401	50	5	694	504	373	666	10	8	50	38	35	13x18
560	1030	892	603	714	383	280	125	390	844	433	483	653	100	439	48	7	770	564	411	742	12	8	70	43	40	13x18
630	1157	998	679	800	433	328	110	434	945	483	533	703	100	489	53	6	856	634	461	828	12	8	70	43	40	13x18

All Dimensions in mm.

ASA 315-400 'T'

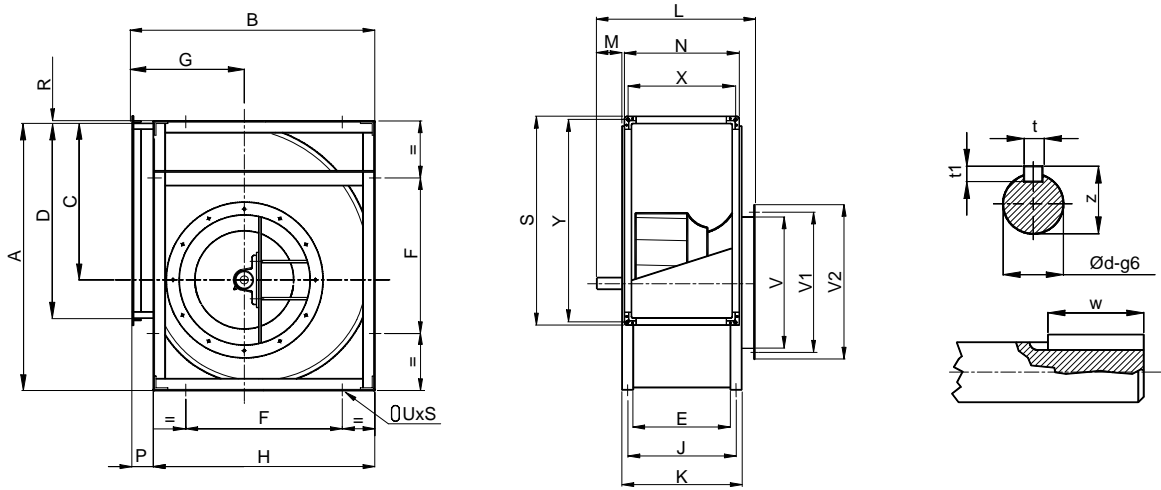

Model	A	B	C	D	E	F	G	H	J	K	L	M	N	P	R	S	V	V1	V2	X	Y	t	t1	w	z	Ød	UxS
315	578	518	340	404	223	330	236	480	253	283	451	78	279	38	3	460	315	356	395	251	432	8	7	40	28	25	13x18
355	654	578	383	452	247	368	260	548	287	327	481	74	303	30	6	508	355	395	435	275	480	8	7	40	33	30	13x18
400	736	650	432	506	274	402	290	612	314	354	508	74	330	38	5	562	400	438	480	302	534	8	7	40	33	30	13x18

All Dimensions in mm.

ASA 450-1000 'T'

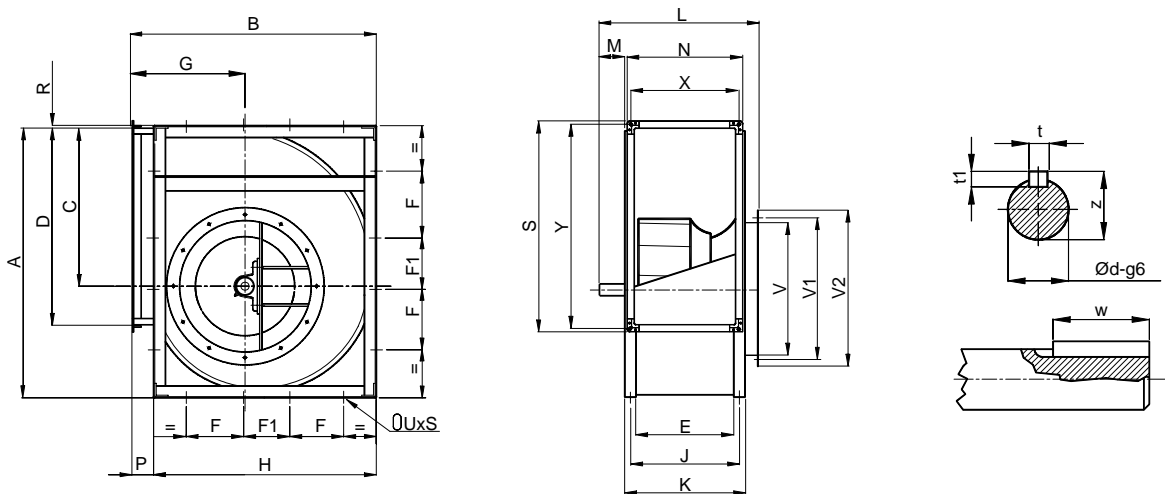

Model	A	B	C	D	E	F	F1	G	H	J	K	L	M	N	P	R	S	V	V1	V2	X	Y	t	t1	w	z	Ød	UxS
450	827	726	486	568	308	200	111	322	681	348	388	564	96	364	45	5	624	450	487	530	336	596	10	8	50	38	35	13x18
500	918	800	538	638	345	245	120	352	750	385	425	601	96	401	50	5	694	500	541	580	373	666	10	8	50	38	35	13x18
560	1030	892	603	714	383	280	125	390	844	433	483	661	108	439	48	7	770	560	605	646	411	742	12	8	70	43	40	13x18
630	1157	998	679	800	433	328	110	434	945	483	533	711	108	489	53	6	856	630	674	716	461	828	12	8	70	43	40	13x18
710	1302	1120	765	898	479	360	150	484	1057	529	579	763	114	535	63	7	954	710	751	796	507	926	14	9	70	48.5	45	17x22
800	1468	1254	862	1006	533	405	171	540	1180	583	633	817	114	589	74	7	1062	800	837	886	561	1034	14	9	70	48.5	45	17x22
900	1648	1408	971	1130	595	455	189	604	1319	645	695	906	141	651	89	7	1186	900	934	986	623	1158	16	10	90	53.5	55	17x22
1000	1810	1540	1066	1266	663	500	200	656	1450	713	763	974	141	719	90	9	1322	1000	1043	1086	691	1294	16	10	90	53.5	55	17x22

All Dimensions in mm.

ASA 1120-1400 'T'

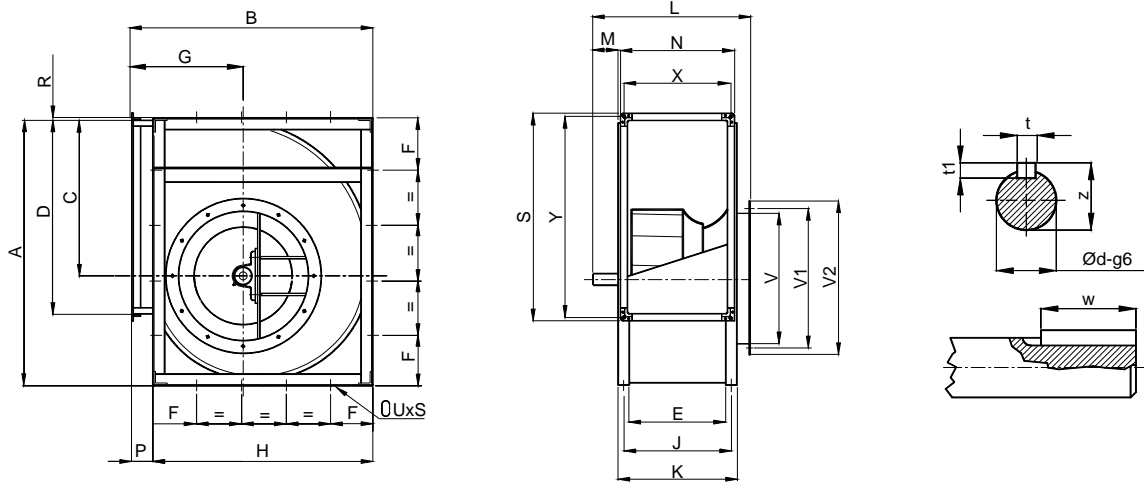

Model	A	B	C	D	E	F	G	H	J	K	L	M	N	P	R	S	V	V1	V2	X	Y	t	t1	w	z	Ød	UxS
1120	2033	1725	1200	1422	744	290	748	1630	804	870	1146	133	800	95	9	1478	1120	1180	1226	772	1450	18	11	90	64	60	17x22
1250	2285	1930	1353	1524	807	300	830	1831	882	957	1232	148	859	99	9	1580	1250	1303	1356	831	1552	18	11	110	69	65	17x22
1400	2568	2170	1515	1794	938	310	963	2057	1013	1088	1381	166	990	113	13	1850	1400	1480	1506	962	1822	20	12	110	74.5	70	17x22

All Dimensions in mm.

ASA 315-400 'X'

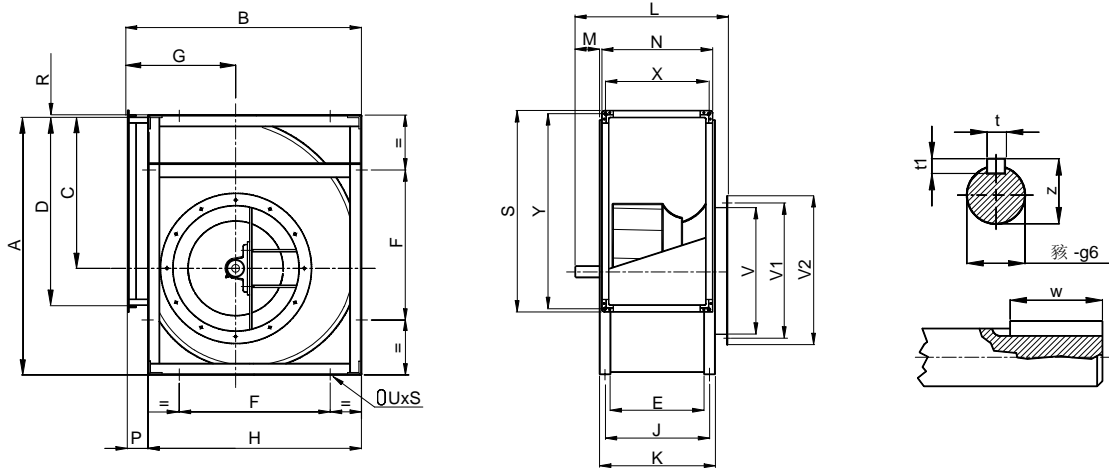

Model	A	B	C	D	E	F	G	H	J	K	L	M	N	P	R	S	V	V1	V2	X	Y	t	t1	w	z	Ød	UxS
315	578	518	340	404	223	330	236	480	253	283	457	84	279	38	3	460	315	356	395	251	432	8	7	40	33	30	13x18
355	654	578	383	452	247	368	260	548	287	327	503	96	303	30	6	508	355	395	435	275	480	10	8	50	38	35	13x18
400	736	650	432	506	274	402	290	612	314	354	530	96	330	38	5	562	400	438	480	302	534	10	8	50	38	35	13x18

All Dimensions in mm.

ASA 450-1000 'X'

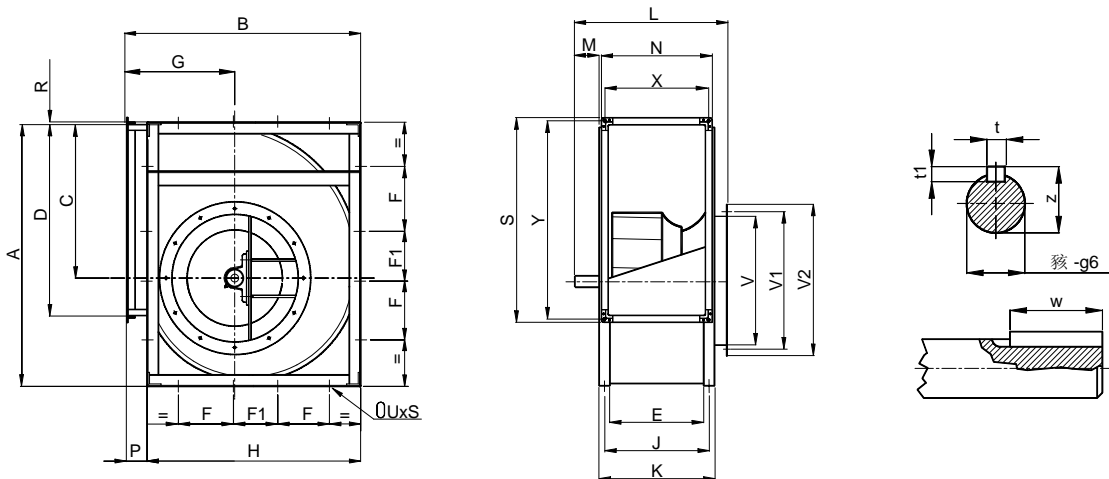

Model	A	B	C	D	E	F	F1	G	H	J	K	L	M	N	P	R	S	V	V1	V2	X	Y	t	t1	w	z	Ød	UxS
450	827	726	486	568	308	200	111	322	681	348	388	586	118	364	45	5	624	450	487	530	336	596	12	8	70	43	40	13x18
500	918	800	538	638	345	245	120	352	750	385	425	623	118	401	50	5	694	500	541	580	373	666	12	8	70	43	40	13x18
560	1030	892	603	714	383	280	125	390	844	433	483	667	114	439	48	7	770	560	605	646	411	742	14	9	70	48.5	45	13x18
630	1157	998	679	800	433	328	110	434	945	483	533	717	114	489	53	6	856	630	674	716	461	828	14	9	70	48.5	45	13x18
710	1302	1120	765	898	479	360	150	484	1057	529	579	787	138	535	63	7	954	710	751	796	507	926	14	9	90	53.5	50	17x22
800	1468	1254	862	1006	533	405	171	540	1180	583	633	841	138	589	74	7	1062	800	837	886	561	1034	14	9	90	53.5	50	17x22
900	1648	1408	971	1130	595	455	189	604	1319	645	695	911	146	651	89	7	1186	900	934	986	623	1158	18	11	90	64	60	17x22
1000	1810	1540	1066	1266	663	500	200	656	1450	713	763	979	146	719	90	9	1322	1000	1043	1086	691	1294	18	11	90	64	60	17x22

All Dimensions in mm.

ASA 1120-1400 'X'

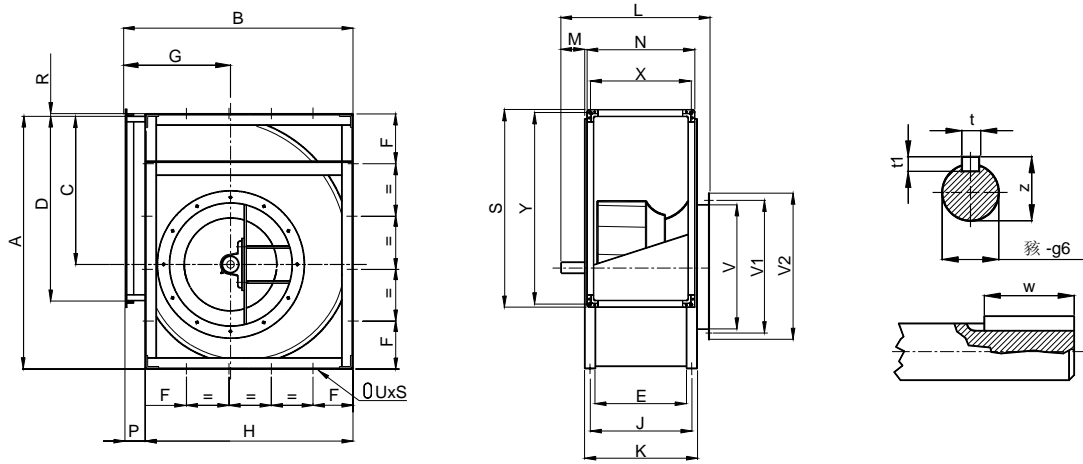

Model	A	B	C	D	E	F	G	H	J	K	L	M	N	P	R	S	V	V1	V2	X	Y	t	t1	w	z	Ød	UxS
1120	2033	1725	1200	1422	744	290	748	1630	804	870	1173	160	800	95	9	1478	1120	1180	1226	772	1450	18	11	110	69	65	17x22
1250	2285	1930	1353	1524	807	300	830	1831	882	957	1250	166	859	99	9	1580	1250	1303	1356	831	1552	20	12	110	74.5	70	17x22
1400	2568	2170	1515	1794	938	310	963	2057	1013	1088	1396	181	990	113	13	1850	1400	1480	1506	962	1822	22	14	110	85	80	17x22

All Dimensions in mm.

ASA 315-400 'UI'

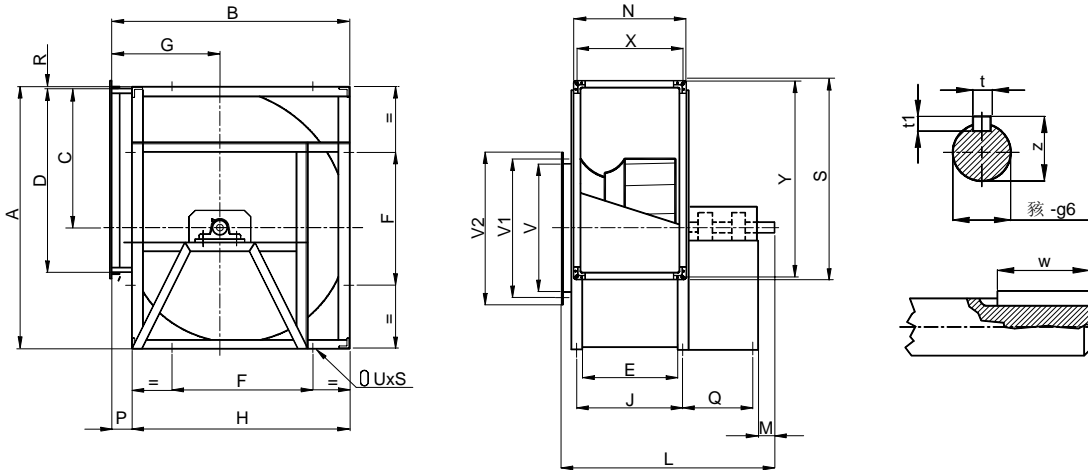

Model	A	B	C	D	E	F	G	H	J	L	M	N	P	Q	R	S	V	V1	V2	X	Y	t	t1	w	z	Ød	UxS
315	578	518	340	404	223	330	236	480	253	705	60	279	38	274	3	460	315	356	395	251	432	8	7	40	28	25	13x18
355	654	578	383	452	247	368	260	548	287	765	60	303	30	300	6	508	355	395	435	275	480	8	7	40	33	30	13x18
400	736	650	432	506	274	402	290	612	314	812	60	330	38	320	5	562	400	438	480	302	534	8	7	40	33	30	13x18

All Dimensions in mm.

ASA 450-1000 'UI'

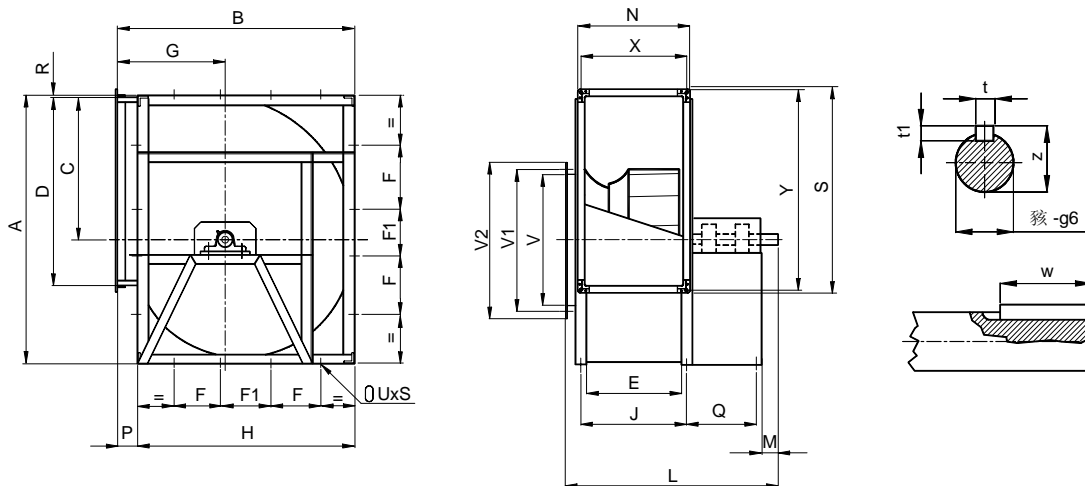

Model	A	B	C	D	E	F	F1	G	H	J	L	M	N	P	Q	R	S	V	V1	V2	X	Y	t	t1	w	z	Ød	UxS
450	827	726	486	568	308	200	111	322	681	348	876	80	364	45	340	5	624	450	487	530	336	596	10	8	50	38	35	13x18
500	918	800	538	638	345	245	120	352	750	385	933	80	401	50	360	5	694	500	541	580	373	666	10	8	50	38	35	13x18
560	1030	892	603	714	383	280	125	390	844	433	1018	90	439	48	378	7	770	560	605	646	411	742	12	8	70	43	40	13x18
630	1157	998	679	800	433	328	110	434	945	483	1090	90	489	53	400	6	856	630	674	716	461	828	12	8	70	43	40	13x18
710	1302	1120	765	898	479	360	150	484	1057	529	1156	90	535	63	420	7	954	710	751	796	507	926	14	9	70	48.5	45	17x22
800	1468	1254	862	1006	533	405	171	540	1180	583	1228	90	589	74	440	7	1062	800	837	886	561	1034	14	9	70	48.5	45	17x22
900	1648	1408	971	1130	595	455	189	604	1319	645	1360	110	651	89	490	7	1186	900	934	986	623	1158	16	10	90	53.5	55	17x22
1000	1810	1540	1066	1266	663	500	200	656	1450	713	1448	110	719	90	510	9	1322	1000	1043	1086	691	1294	16	10	90	53.5	55	17x22

All Dimensions in mm.

ASA 1120-1400 'UI'

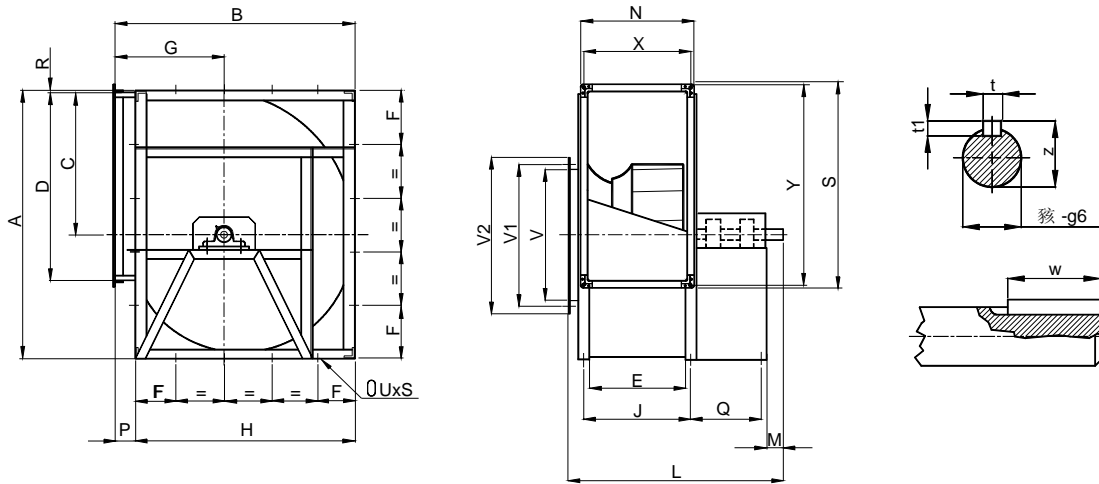

Model	A	B	C	D	E	F	G	H	J	L	M	N	P	Q	R	S	V	V1	V2	X	Y	t	t1	w	z	Ød	UxS
1120	2033	1725	1200	1422	744	290	748	1630	804	1680	110	800	95	572	9	1478	1120	1180	1226	772	1450	18	11	90	64	60	17x22
1250	2285	1930	1353	1524	807	300	830	1831	882	1844	140	859	99	632	9	1580	1250	1303	1356	831	1552	18	11	110	69	65	17x22
1400	2568	2170	1515	1794	938	310	963	2057	1013	2060	140	990	113	717	13	1850	1400	1480	1506	962	1822	20	12	110	74.5	70	17x22

All Dimensions in mm.

ASA 315-400 'UII'

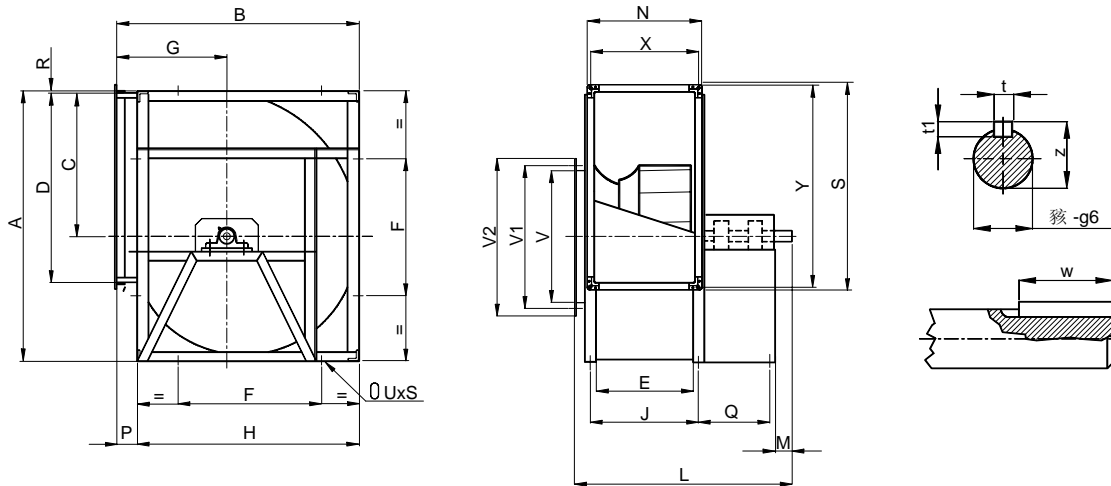

Model	A	B	C	D	E	F	G	H	J	L	M	N	P	Q	R	S	V	V1	V2	X	Y	t	t1	w	z	Ød	UxS
315	578	518	340	404	223	330	236	480	253	705	60	279	38	274	3	460	315	356	395	251	432	8	7	40	28	25	13x18
355	654	578	383	452	247	368	260	548	287	765	60	303	30	300	6	508	355	395	435	275	480	8	7	40	33	30	13x18
400	736	650	432	506	274	402	290	612	314	812	60	330	38	320	5	562	400	438	480	302	534	8	7	40	33	30	13x18

All Dimensions in mm.

ASA 450-1000 'UII'

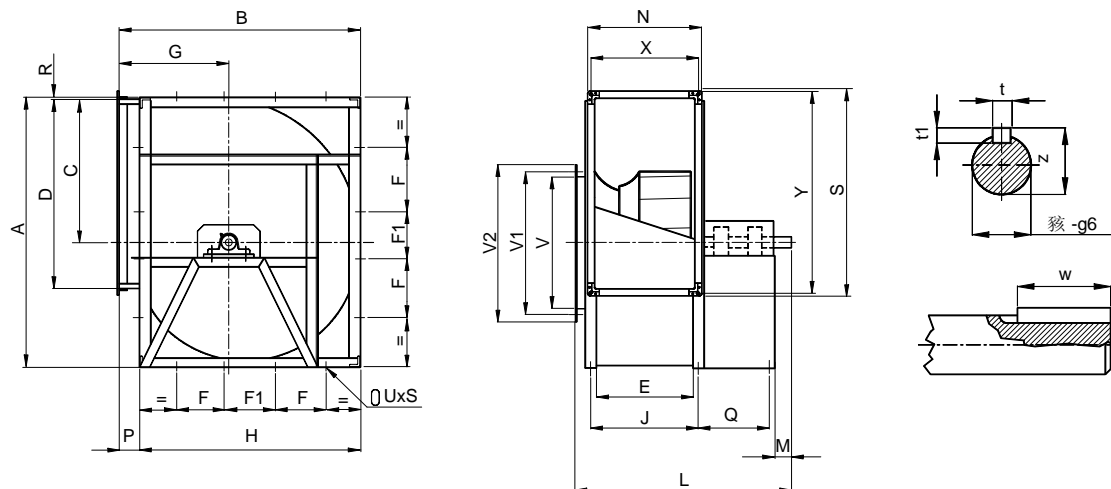

Model	A	B	C	D	E	F	F1	G	H	J	L	M	N	P	Q	R	S	V	V1	V2	X	Y	t	t1	w	z	Ød	UxS
450	827	726	486	568	308	200	111	322	681	348	876	70	364	45	340	5	624	450	487	530	336	596	10	8	50	38	35	13x18
500	918	800	538	638	345	245	120	352	750	385	933	70	401	50	360	5	694	500	541	580	373	666	10	8	50	38	35	13x18
560	1030	892	603	714	383	280	125	390	844	433	1018	90	439	48	378	7	770	560	605	646	411	742	12	8	70	43	40	13x18
630	1157	998	679	800	433	328	110	434	945	483	1090	90	489	53	400	6	856	630	674	716	461	828	12	8	70	43	40	13x18
710	1302	1120	765	898	479	360	150	484	1057	529	1176	110	535	63	420	7	954	710	751	796	507	926	14	9	90	53.5	50	17x22
800	1468	1254	862	1006	533	405	171	540	1180	583	1248	110	589	74	440	7	1062	800	837	886	561	1034	14	9	90	53.5	50	17x22
900	1648	1408	971	1130	595	455	189	604	1319	645	1360	110	651	89	490	7	1186	900	934	986	623	1158	18	11	90	64	60	17x22
1000	1810	1540	1066	1266	663	500	200	656	1450	713	1448	110	719	90	510	9	1322	1000	1043	1086	691	1294	18	11	90	64	60	17x22

All Dimensions in mm.

ASA 1120-1400 'UII'

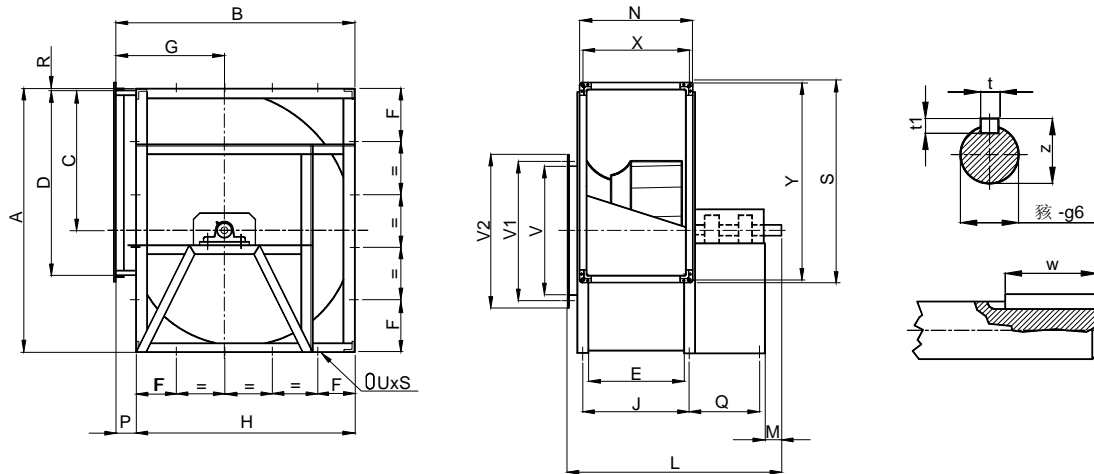

Model	A	B	C	D	E	F	G	H	J	L	M	N	P	Q	R	S	V	V1	V2	X	Y	t	t1	w	z	Ød	UxS
1120	2033	1725	1200	1422	744	290	748	1630	804	1710	140	800	95	572	9	1478	1120	1180	1226	772	1450	18	11	110	69	65	17x22
1250	2285	1930	1353	1524	807	300	830	1831	882	1844	140	859	99	632	9	1580	1250	1303	1356	831	1552	20	12	110	74.5	70	17x22
1400	2568	2170	1515	1794	938	310	963	2057	1013	2060	140	990	113	717	13	1850	1400	1480	1506	962	1822	22	14	110	85	80	17x22

All Dimensions in mm.

OVERALL DIMENSION – ASA “C” SERIES

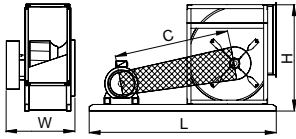
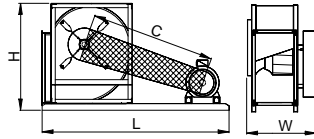
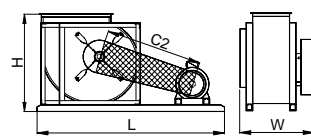
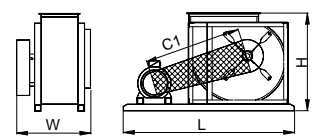
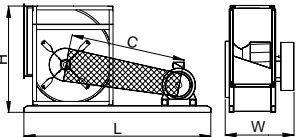
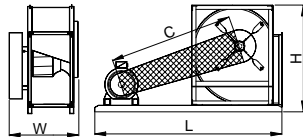
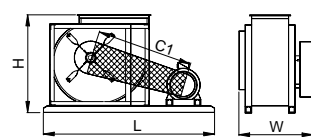
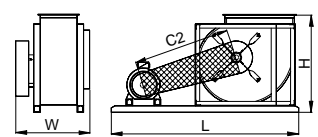
CW 90° (Pos Z)

CW 270° (Pos W)

CW 360° (Pos W)

CW 360° (Pos Z)

CCW 90° (Pos W)

CCW 270° (Pos Z)

CCW 360° (Pos W)

CCW 360° (Pos Z)

Model	Motor Frame Size	90°/ 270°						360°					
		C (90°)	C (270°)	L	W	H	* Wt (kg)	C1	C2	L	W	H	* Wt (kg)
315	63	432	476	740	481	618	24	507	407	840	481	558	25
	71	460	500	780	481	618	24	534	433	880	481	558	25
	80	488	524	820	481	618	25	561	459	920	481	558	25
	90	515	547	860	481	618	25	587	484	960	481	558	25
	100	542	571	900	481	618	25	614	509	1000	481	558	25
	112	568	594	940	481	618	25	638	533	1040	481	558	26
355	71	496	547	840	509	694	30	593	479	960	509	618	31
	80	523	570	880	509	694	30	601	485	980	509	618	31
	90	549	592	920	509	694	30	626	509	1020	509	618	31
	100	576	615	960	509	694	31	652	534	1060	509	618	31
	112	620	654	1020	509	694	31	695	575	1120	509	618	31
400	71	561	621	920	536	776	38	651	527	1040	536	690	39
	80	569	626	940	536	776	39	677	550	1080	536	690	39
	90	595	647	980	536	776	39	702	573	1120	536	690	39
	100	621	669	1020	536	776	39	727	597	1160	536	690	40
	112	664	708	1080	536	776	39	750	619	1200	536	690	40
	132	719	756	1160	536	776	40	823	689	1300	536	690	40
450	71	607	680	980	586	867	48	708	571	1120	586	766	49
	80	633	701	1020	586	867	48	733	593	1160	586	766	49
	90	658	722	1060	586	867	48	757	615	1200	586	766	49
	100	684	743	1100	586	867	49	791	647	1250	586	766	49
	112	707	763	1140	586	867	49	824	678	1300	586	766	50
	132	741	790	1200	586	867	49	846	699	1350	586	766	50
500	71	654	736	1060	623	968	65	791	642	1250	623	850	66
	80	661	740	1080	623	968	65	779	629	1250	623	850	66
	90	686	760	1120	623	968	65	812	659	1300	623	850	67
	100	711	780	1160	623	968	66	845	691	1350	623	850	67
	112	734	799	1200	623	968	66	877	720	1400	623	850	67
	132	805	861	1300	623	968	67	899	740	1450	623	850	68
560	80	734	827	1180	683	1080	89	897	728	1400	683	942	91
	90	739	830	1200	683	1080	89	884	714	1400	683	942	91
	100	773	858	1250	683	1080	90	916	744	1450	683	942	91
	112	804	884	1300	683	1080	90	947	773	1500	683	942	92
	132	875	945	1400	683	1080	91	968	792	1550	683	942	92
	160	938	998	1500	683	1080	92	1028	848	1650	683	942	93
630	80	829	937	1300	733	1207	115	967	782	1500	733	1048	117
	90	862	964	1350	733	1207	116	998	811	1550	733	1048	117
	100	848	950	1350	733	1207	116	1031	840	1600	733	1048	118
	112	879	975	1400	733	1207	116	1061	868	1650	733	1048	118
	132	948	1034	1500	733	1207	117	1082	886	1700	733	1048	119
	160	1010	1085	1600	733	1207	118	1140	940	1800	733	1048	119

* The above weight does not include motor and drive unit as these will vary with supplier.

All Dimensions in mm.

OVERALL DIMENSION - ASA "T" SERIES

CW 90° (Pos Z)

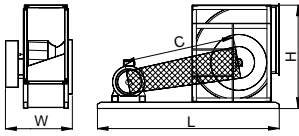

CW 270° (Pos W)

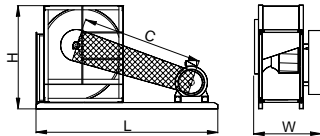

CW 360° (Pos W)

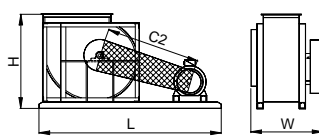

CW 360° (Pos Z)

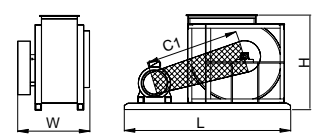

CCW 90° (Pos W)

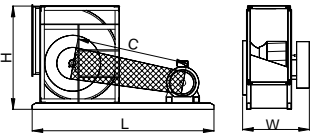

CCW 270° (Pos Z)

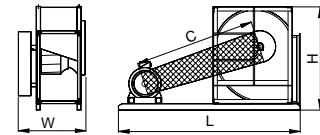

CCW 360° (Pos W)

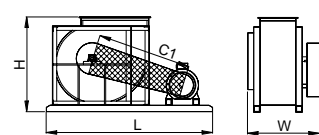

CCW 360° (Pos Z)

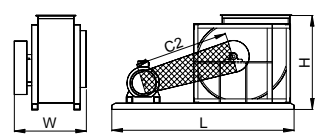

Model	Motor Frame Size	90°/ 270°						360°					
		C (90°)	C (270°)	L	W	H	* Wt (kg)	C1	C2	L	W	H	* Wt (kg)
315	80	488	524	820	481	618	39	561	459	920	481	558	39
	90	515	547	860	481	618	39	587	484	960	481	558	39
	100	542	571	900	481	618	39	614	509	1000	481	558	39
	112	568	594	940	481	618	39	638	533	1040	481	558	40
	132	625	645	1020	481	618	40	694	587	1120	481	558	40
355	80	523	570	880	511	694	54	601	485	980	511	618	55
	90	549	592	920	511	694	54	626	509	1020	511	618	55
	100	576	615	960	511	694	55	652	534	1060	511	618	55
	112	620	654	1020	511	694	55	695	575	1120	511	618	55
	132	676	704	1100	511	694	55	749	628	1200	511	618	56
400	90	595	647	980	538	776	65	702	573	1120	538	690	65
	100	621	669	1020	538	776	65	727	597	1160	538	690	66
	112	664	708	1080	538	776	65	750	619	1200	538	690	66
	132	719	756	1160	538	776	66	823	689	1300	538	690	66
	160	776	806	1250	538	776	66	888	752	1400	538	690	67
450	90	658	722	1060	594	867	77	757	615	1200	594	766	78
	100	684	743	1100	594	867	78	791	647	1250	594	766	78
	112	707	763	1140	594	867	78	824	678	1300	594	766	79
	132	741	790	1200	594	867	78	846	699	1350	594	766	79
	160	807	847	1300	594	867	79	909	759	1450	594	766	79
500	90	686	760	1120	631	968	99	812	659	1300	631	850	101
	100	711	780	1160	631	968	100	845	691	1350	631	850	101
	112	734	799	1200	631	968	100	877	720	1400	631	850	101
	132	805	861	1300	631	968	101	899	740	1450	631	850	102
	160	870	917	1400	631	968	101	961	799	1550	631	850	103
560	100	773	858	1250	691	1080	137	916	744	1450	691	942	138
	112	804	884	1300	691	1080	137	947	773	1500	691	942	139
	132	875	945	1400	691	1080	138	968	792	1550	691	942	139
	160	938	998	1500	691	1080	139	1028	848	1650	691	942	140
	180	1012	1064	1600	691	1080	139	1100	917	1750	691	942	141
630	100	848	950	1350	741	1207	167	985	797	1550	741	1048	168
	112	879	975	1400	741	1207	167	1015	824	1600	741	1048	169
	132	948	1034	1500	741	1207	168	1082	886	1700	741	1048	170
	160	1010	1085	1600	741	1207	169	1140	940	1800	741	1048	170
	180	1034	1103	1650	741	1207	169	1211	1008	1900	741	1048	171
	200	1107	1169	1750	741	1207	170	1235	1030	1950	741	1048	172
710	90	907	1028	1450	793	1382	214	1080	868	1700	793	1200	217
	100	941	1055	1500	793	1382	215	1112	897	1750	793	1200	218
	112	972	1080	1550	793	1382	215	1142	924	1800	793	1200	218
	132	993	1095	1600	793	1382	216	1162	941	1850	793	1200	219
	160	1054	1144	1700	793	1382	217	1220	994	1950	793	1200	220
	180	1126	1207	1800	793	1382	218	1290	1061	2050	793	1200	221
800	100	1018	1156	1600	847	1548	255	1218	983	1900	847	1334	259
	112	1048	1180	1650	847	1548	256	1247	1009	1950	847	1334	260
	132	1115	1235	1750	847	1548	257	1267	1024	2000	847	1334	260
	160	1174	1283	1850	847	1548	258	1370	1120	2150	847	1334	262
	180	1197	1300	1900	847	1548	259	1391	1139	2200	847	1334	263
	200	1269	1362	2000	847	1548	260	1461	1206	2300	847	1334	264

* The above weight does not include motor and drive unit as these will vary with supplier.

All Dimensions in mm.

OVERALL DIMENSION - ASA "X" SERIES

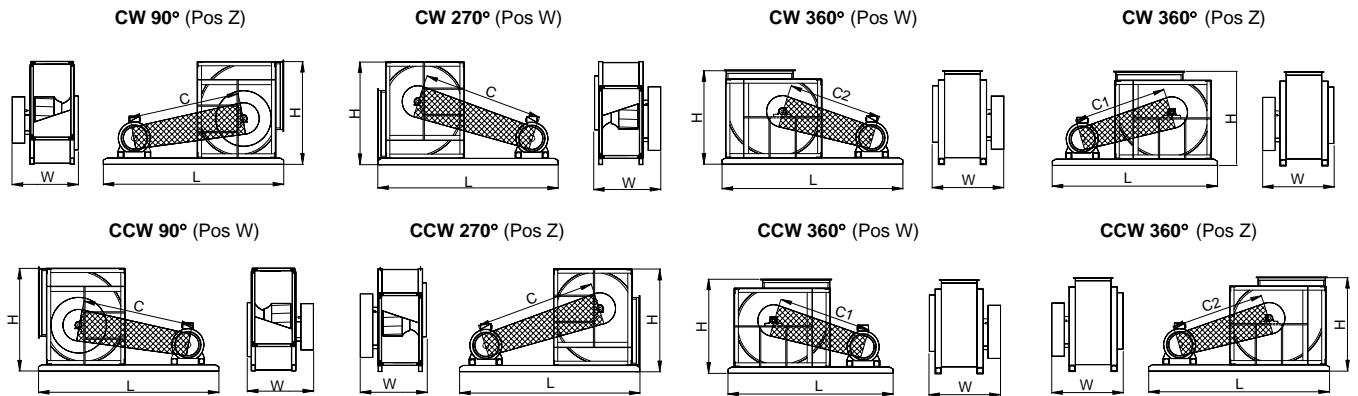

Model	Motor Frame Size	90°/ 270°						360°					
		C (90°)	C (270°)	L	W	H	* Wt (kg)	C1	C2	L	W	H	* Wt (kg)
315	112	568	594	940	487	618	41	638	533	1040	487	558	42
	132	625	645	1020	487	618	42	694	587	1120	487	558	42
	160	715	728	1140	487	618	42	791	684	1250	487	558	43
355	132	676	704	1100	533	694	57	749	628	1200	533	618	58
	160	745	766	1200	533	694	58	816	693	1300	533	618	58
	180	823	839	1300	533	694	58	892	769	1400	533	618	59
400	132	719	756	1160	560	776	67	823	689	1300	560	690	67
	160	776	806	1250	560	776	67	888	752	1400	560	690	68
	180	854	877	1350	560	776	68	914	778	1450	560	690	68
450	160	807	847	1300	616	867	81	909	759	1450	616	766	81
	180	883	916	1400	616	867	81	983	832	1550	616	766	82
	200	960	987	1500	616	867	82	1059	906	1650	616	766	82
500	160	870	917	1400	653	968	103	961	799	1550	653	850	105
	180	945	985	1500	653	968	104	1034	871	1650	653	850	105
	200	972	1008	1550	653	968	105	1109	944	1750	653	850	106
560	160	938	998	1500	697	1080	142	1076	895	1700	697	942	143
	180	1012	1064	1600	697	1080	142	1100	917	1750	697	942	144
	200	1038	1085	1650	697	1080	143	1173	989	1850	697	942	144
	225	1109	1149	1750	697	1080	144	1242	1056	1950	697	942	145
630	180	1034	1103	1650	747	1207	171	1211	1008	1900	747	1048	173
	200	1107	1169	1750	747	1207	172	1235	1030	1950	747	1048	174
	225	1177	1230	1850	747	1207	173	1301	1095	2050	747	1048	174
	250	1247	1294	1950	747	1207	174	1370	1161	2150	747	1048	175
710	160	1054	1144	1700	817	1382	220	1220	994	1950	817	1200	223
	180	1126	1207	1800	817	1382	221	1290	1061	2050	817	1200	224
	200	1150	1226	1850	817	1382	222	1313	1082	2100	817	1200	225
	225	1219	1286	1950	817	1382	223	1379	1146	2200	817	1200	226
800	180	1197	1300	1900	871	1548	263	1391	1139	2200	871	1334	267
	200	1269	1362	2000	871	1548	264	1461	1206	2300	871	1334	268
	225	1336	1420	2100	871	1548	266	1526	1268	2400	871	1334	269
	250	1404	1480	2200	871	1548	267	1592	1332	2500	871	1334	270
900	180	1315	1441	2050	941	1728	324	1543	1260	2400	941	1488	328
	200	1385	1501	2150	941	1728	325	1564	1278	2450	941	1488	329
	225	1451	1557	2250	941	1728	326	1627	1338	2550	941	1488	330
	250	1518	1615	2350	941	1728	327	1692	1399	2650	941	1488	331
1000	200	1451	1591	2250	1009	1890	375	1719	1405	2650	1009	1620	380
	225	1515	1644	2350	1009	1890	376	1781	1463	2750	1009	1620	381
	250	1581	1700	2450	1009	1890	377	1844	1523	2850	1009	1620	382
	280	1690	1796	2600	1009	1890	379	1903	1579	2950	1009	1620	384
1120	200	1616	1773	2450	1203	2158	675	1836	1482	2800	1203	1850	684
	225	1680	1827	2550	1203	2158	678	1945	1585	2950	1203	1850	688
	250	1746	1882	2650	1203	2158	680	2008	1645	3050	1203	1850	691
	280	1806	1932	2750	1203	2158	683	2067	1700	3150	1203	1850	694
1250	200	1717	1914	2600	1275	2410	950	2068	1669	3100	1275	2055	974
	225	1779	1965	2700	1275	2410	955	2129	1725	3200	1275	2055	979
	250	1842	2017	2800	1275	2410	960	2190	1782	3300	1275	2055	984
	280	1901	2064	2900	1275	2410	965	2247	1835	3400	1275	2055	989
1400	225	1942	2164	2950	1422	2693	1262	2291	1848	3450	1422	2295	1286
	250	2004	2214	3050	1422	2693	1267	2352	1903	3550	1422	2295	1291
	280	2060	2259	3150	1422	2693	1272	2408	1954	3650	1422	2295	1296
	315	2160	2343	3300	1422	2693	1279	2505	2046	3800	1422	2295	1303

* The above weight does not include motor and drive unit as these will vary with supplier.

All Dimensions in mm.

OVERALL DIMENSION – ASA “UI” SERIES

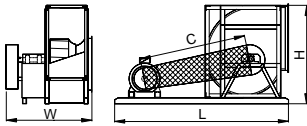
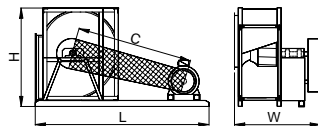
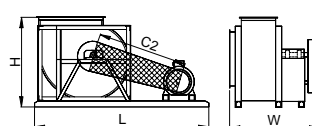
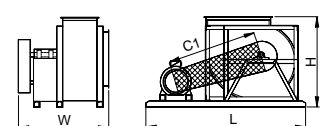
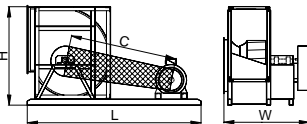
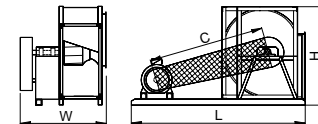
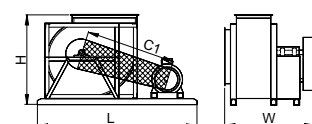
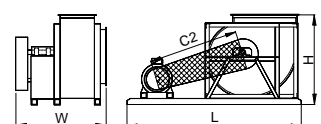
CW 90° (Pos Z)

CW 270° (Pos W)

CW 360° (Pos W)

CW 360° (Pos Z)

CCW 90° (Pos W)

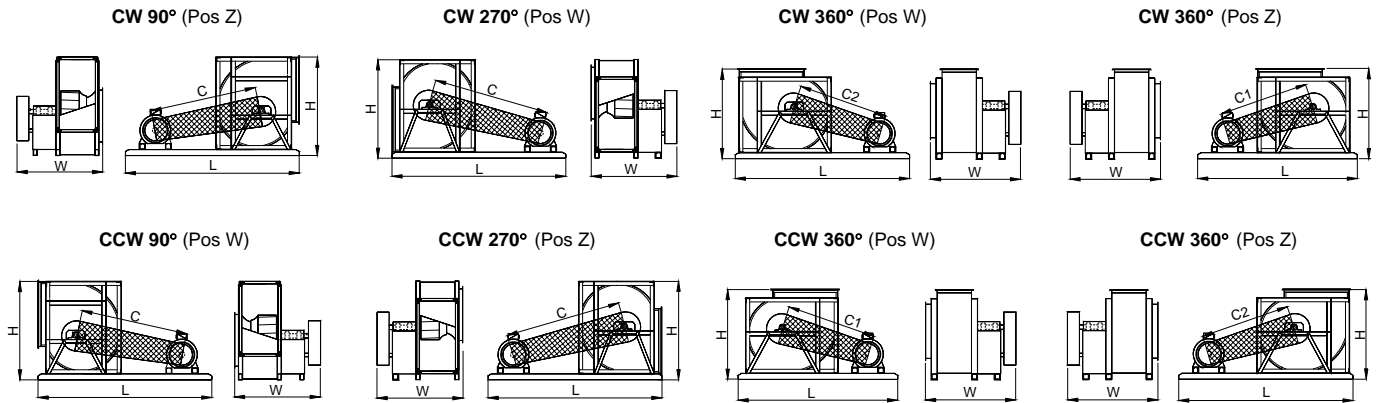
CCW 270° (Pos Z)

CCW 360° (Pos W)

CCW 360° (Pos Z)

Model	Motor Frame Size	90°/ 270°							360°					
		C (90°)	C (270°)	L	W	H	* Wt (kg) 90°	* Wt (kg) 270°	C1	C2	L	W	H	* Wt (kg)
315	63	432	476	740	735	618	40	41	507	407	840	735	558	41
	71	460	500	780	735	618	40	41	534	433	880	735	558	41
	80	488	524	820	735	618	41	41	561	459	920	735	558	41
	90	515	547	860	735	618	41	41	587	484	960	735	558	42
	100	542	571	900	735	618	41	42	614	509	1000	735	558	42
	112	568	594	940	735	618	42	42	638	533	1040	735	558	42
355	71	496	547	840	795	694	52	55	593	479	960	795	618	55
	80	523	570	880	795	694	53	55	601	485	980	795	618	55
	90	549	592	920	795	694	53	55	626	509	1020	795	618	56
	100	576	615	960	795	694	53	56	652	534	1060	795	618	56
	112	620	654	1020	795	694	54	56	695	575	1120	795	618	56
400	71	561	621	920	842	776	63	65	651	527	1040	842	690	65
	80	569	626	940	842	776	63	65	677	550	1080	842	690	65
	90	595	647	980	842	776	64	65	702	573	1120	842	690	66
	100	621	669	1020	842	776	64	65	727	597	1160	842	690	66
	112	664	708	1080	842	776	64	66	750	619	1200	842	690	66
	132	719	756	1160	842	776	65	66	823	689	1300	842	690	67
450	71	607	680	980	906	867	78	79	708	571	1120	906	766	78
	80	633	701	1020	906	867	78	79	733	593	1160	906	766	79
	90	658	722	1060	906	867	78	79	757	615	1200	906	766	79
	100	684	743	1100	906	867	79	80	791	647	1250	906	766	79
	112	707	763	1140	906	867	79	80	824	678	1300	906	766	80
	132	741	790	1200	906	867	79	80	846	699	1350	906	766	80
500	71	654	736	1060	963	968	101	101	791	642	1250	963	850	102
	80	661	740	1080	963	968	101	101	779	629	1250	963	850	102
	90	686	760	1120	963	968	102	102	812	659	1300	963	850	103
	100	711	780	1160	963	968	102	102	845	691	1350	963	850	103
	112	734	799	1200	963	968	103	103	877	720	1400	963	850	104
	132	805	861	1300	963	968	104	104	899	740	1450	963	850	105
560	80	734	827	1180	1048	1080	131	134	897	728	1400	1048	942	135
	90	739	830	1200	1048	1080	131	134	884	714	1400	1048	942	135
	100	773	858	1250	1048	1080	132	135	916	744	1450	1048	942	136
	112	804	884	1300	1048	1080	132	135	947	773	1500	1048	942	136
	132	875	945	1400	1048	1080	133	136	968	792	1550	1048	942	137
	160	938	998	1500	1048	1080	135	138	1028	848	1650	1048	942	138
630	80	829	937	1300	1120	1207	161	164	967	782	1500	1120	1048	165
	90	862	964	1350	1120	1207	161	164	998	811	1550	1120	1048	165
	100	848	950	1350	1120	1207	161	164	1031	840	1600	1120	1048	166
	112	879	975	1400	1120	1207	162	165	1061	868	1650	1120	1048	167
	132	948	1034	1500	1120	1207	163	166	1082	886	1700	1120	1048	167
	160	1010	1085	1600	1120	1207	164	167	1140	940	1800	1120	1048	168
710	90	907	1028	1450	1186	1382	219	220	1080	868	1700	1186	1200	226
	100	941	1055	1500	1186	1382	220	221	1112	897	1750	1186	1200	226
	112	972	1080	1550	1186	1382	221	222	1142	924	1800	1186	1200	227
	132	993	1095	1600	1186	1382	222	223	1162	941	1850	1186	1200	228
	160	1054	1144	1700	1186	1382	224	225	1220	994	1950	1186	1200	230
	180	1126	1207	1800	1186	1382	225	227	1290	1061	2050	1186	1200	232

* The above weight does not include motor and drive unit as these will vary with supplier.

All Dimensions in mm.

OVERALL DIMENSION – ASA “UI” SERIES



Model	Motor Frame Size	90°/ 270°							360°					
		C (90°)	C (270°)	L	W	H	* Wt (kg) 90°	* Wt (kg) 270°	C1	C2	L	W	H	* Wt (kg)
800	100	1018	1156	1600	1258	1548	286	294	1218	983	1900	1258	1334	297
	112	1048	1180	1650	1258	1548	287	295	1247	1009	1950	1258	1334	298
	132	1115	1235	1750	1258	1548	289	297	1267	1024	2000	1258	1334	299
	160	1174	1283	1850	1258	1548	291	299	1370	1120	2150	1258	1334	302
	180	1197	1300	1900	1258	1548	292	300	1391	1139	2200	1258	1334	303
	200	1269	1362	2000	1258	1548	294	301	1461	1206	2300	1258	1334	305
900	100	1140	1302	1750	1390	1728	350	359	1374	1108	2100	1390	1488	366
	112	1169	1325	1800	1390	1728	351	360	1403	1133	2150	1390	1488	367
	132	1189	1338	1850	1390	1728	352	361	1421	1148	2200	1390	1488	368
	160	1293	1425	2000	1390	1728	354	364	1476	1197	2300	1390	1488	370
	180	1315	1441	2050	1390	1728	355	365	1543	1260	2400	1390	1488	372
	200	1385	1501	2150	1390	1728	357	367	1564	1278	2450	1390	1488	373
1000	112	1286	1463	1950	1478	1890	398	405	1514	1222	2300	1478	1620	426
	132	1305	1475	2000	1478	1890	399	405	1532	1236	2350	1478	1620	427
	160	1361	1518	2100	1478	1890	401	407	1586	1282	2450	1478	1620	429
	180	1429	1575	2200	1478	1890	403	409	1651	1343	2550	1478	1620	431
	200	1451	1591	2250	1478	1890	403	410	1719	1405	2650	1478	1620	433
	225	1515	1644	2350	1478	1890	405	412	1781	1463	2750	1478	1620	434
1120	112	1358	1564	2050	1710	2158	728	728	1631	1300	2450	1710	1850	745
	132	1423	1615	2150	1710	2158	732	732	1695	1356	2550	1710	1850	749
	160	1479	1658	2250	1710	2158	736	736	1749	1403	2650	1710	1850	753
	180	1547	1715	2350	1710	2158	740	740	1815	1464	2750	1710	1850	757
	200	1616	1773	2450	1710	2158	744	744	1836	1482	2800	1710	1850	759
	225	1680	1827	2550	1710	2158	748	748	1945	1585	2950	1710	1850	765
	250	1746	1882	2650	1710	2158	752	752	2008	1645	3050	1710	1850	769
1250	132	1575	1805	2350	1869	2410	1088	1088	1884	1504	2800	1869	2055	1123
	160	1629	1846	2450	1869	2410	1096	1096	1937	1550	2900	1869	2055	1130
	180	1696	1900	2550	1869	2410	1103	1103	2002	1608	3000	1869	2055	1137
	200	1717	1914	2600	1869	2410	1106	1106	2068	1669	3100	1869	2055	1144
	225	1779	1965	2700	1869	2410	1114	1114	2129	1725	3200	1869	2055	1152
	250	1842	2017	2800	1869	2410	1121	1121	2190	1782	3300	1869	2055	1159
1400	132	1744	2011	2600	2086	2693	1425	1425	2096	1675	3100	2086	2295	1461
	160	1796	2050	2700	2086	2693	1432	1432	2148	1720	3200	2086	2295	1468
	180	1815	2062	2750	2086	2693	1435	1435	2212	1778	3300	2086	2295	1475
	200	1881	2115	2850	2086	2693	1443	1443	2232	1794	3350	2086	2295	1479
	225	1942	2164	2950	2086	2693	1450	1450	2291	1848	3450	2086	2295	1486
	250	2004	2214	3050	2086	2693	1457	1457	2352	1903	3550	2086	2295	1493
	280	2060	2259	3150	2086	2693	1464	1464	2408	1954	3650	2086	2295	1500

* The above weight does not include motor and drive unit as these will vary with supplier.

All Dimensions in mm.

OVERALL DIMENSION – ASA “UI” SERIES

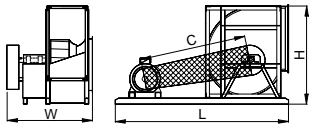
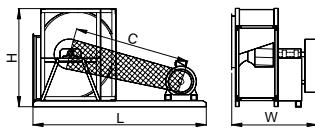
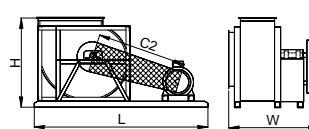
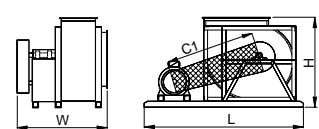
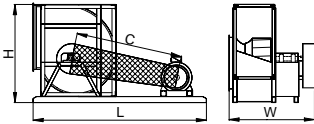
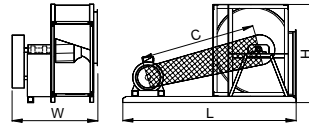
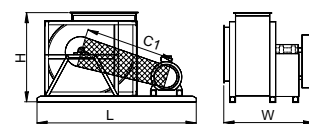
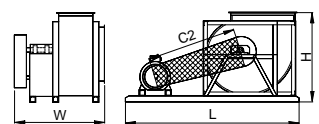
CW 90° (Pos Z)

CW 270°(Pos W)

CW 360° (Pos W)

CW 360° (Pos Z)

CCW 90° (Pos W)

CCW 270° (Pos Z)

CCW 360° (Pos W)

CCW 360° (Pos Z)

Model	Motor Frame Size	90°/ 270°							360°					
		C (90°)	C (270°)	L	W	H	* Wt (kg) 90°	* Wt (kg) 270°	C1	C2	L	W	H	* Wt (kg)
315	80	488	524	820	735	618	41	42	561	459	920	735	558	42
	90	515	547	860	735	618	41	42	587	484	960	735	558	42
	100	542	571	900	735	618	41	42	614	509	1000	735	558	43
	112	568	594	940	735	618	42	43	638	533	1040	735	558	43
	132	625	645	1020	735	618	42	43	694	587	1120	735	558	44
355	80	523	570	880	795	694	53	56	601	485	980	795	618	56
	90	549	592	920	795	694	53	56	626	509	1020	795	618	57
	100	576	615	960	795	694	53	56	652	534	1060	795	618	57
	112	620	654	1020	795	694	54	57	695	575	1120	795	618	57
	132	676	704	1100	795	694	55	58	749	628	1200	795	618	58
400	90	595	647	980	842	776	63	66	702	573	1120	842	690	66
	100	621	669	1020	842	776	63	66	727	597	1160	842	690	67
	112	664	708	1080	842	776	64	66	750	619	1200	842	690	67
	132	719	756	1160	842	776	64	67	823	689	1300	842	690	68
	160	776	806	1250	842	776	65	68	888	752	1400	842	690	68
450	90	658	722	1060	906	867	78	80	757	615	1200	906	766	80
	100	684	743	1100	906	867	78	81	791	647	1250	906	766	81
	112	707	763	1140	906	867	78	81	824	678	1300	906	766	81
	132	741	790	1200	906	867	79	81	846	699	1350	906	766	81
	160	807	847	1300	906	867	80	82	909	759	1450	906	766	82
500	90	686	760	1120	963	968	100	102	812	659	1300	963	850	104
	100	711	780	1160	963	968	101	103	845	691	1350	963	850	104
	112	734	799	1200	963	968	101	103	877	720	1400	963	850	105
	132	805	861	1300	963	968	102	104	899	740	1450	963	850	105
	160	870	917	1400	963	968	103	106	961	799	1550	963	850	107
560	100	773	858	1250	1048	1080	133	136	916	744	1450	1048	942	137
	112	804	884	1300	1048	1080	134	137	947	773	1500	1048	942	138
	132	875	945	1400	1048	1080	135	138	968	792	1550	1048	942	139
	160	938	998	1500	1048	1080	136	139	1028	848	1650	1048	942	140
	180	1012	1064	1600	1048	1080	138	140	1100	917	1750	1048	942	141
630	100	848	950	1350	1120	1207	163	166	985	797	1550	1120	1048	167
	112	879	975	1400	1120	1207	163	167	1015	824	1600	1120	1048	167
	132	948	1034	1500	1120	1207	164	168	1082	886	1700	1120	1048	169
	160	1010	1085	1600	1120	1207	166	169	1140	940	1800	1120	1048	170
	180	1034	1103	1650	1120	1207	166	169	1211	1008	1900	1120	1048	171
	200	1107	1169	1750	1120	1207	167	171	1235	1030	1950	1120	1048	172
710	100	941	1055	1500	1206	1382	221	223	1112	897	1750	1206	1200	228
	112	972	1080	1550	1206	1382	222	224	1142	924	1800	1206	1200	229
	132	993	1095	1600	1206	1382	223	225	1162	941	1850	1206	1200	230
	160	1054	1144	1700	1206	1382	225	227	1220	994	1950	1206	1200	232
	180	1126	1207	1800	1206	1382	227	229	1290	1061	2050	1206	1200	234
	200	1150	1226	1850	1206	1382	228	230	1313	1082	2100	1206	1200	235
	225	1219	1286	1950	1206	1382	230	231	1379	1146	2200	1206	1200	237
800	112	1048	1180	1650	1278	1548	289	297	1247	1009	1950	1278	1334	300
	132	1115	1235	1750	1278	1548	291	299	1267	1024	2000	1278	1334	301
	160	1174	1283	1850	1278	1548	293	301	1370	1120	2150	1278	1334	304
	180	1197	1300	1900	1278	1548	294	302	1391	1139	2200	1278	1334	305
	200	1269	1362	2000	1278	1548	296	304	1461	1206	2300	1278	1334	307
	225	1336	1420	2100	1278	1548	298	305	1526	1268	2400	1278	1334	309
	250	1404	1480	2200	1278	1548	299	307	1592	1332	2500	1278	1334	310

* The above weight does not include motor and drive unit as these will vary with supplier.

All Dimensions in mm.



OVERALL DIMENSION – ASA “UI” SERIES

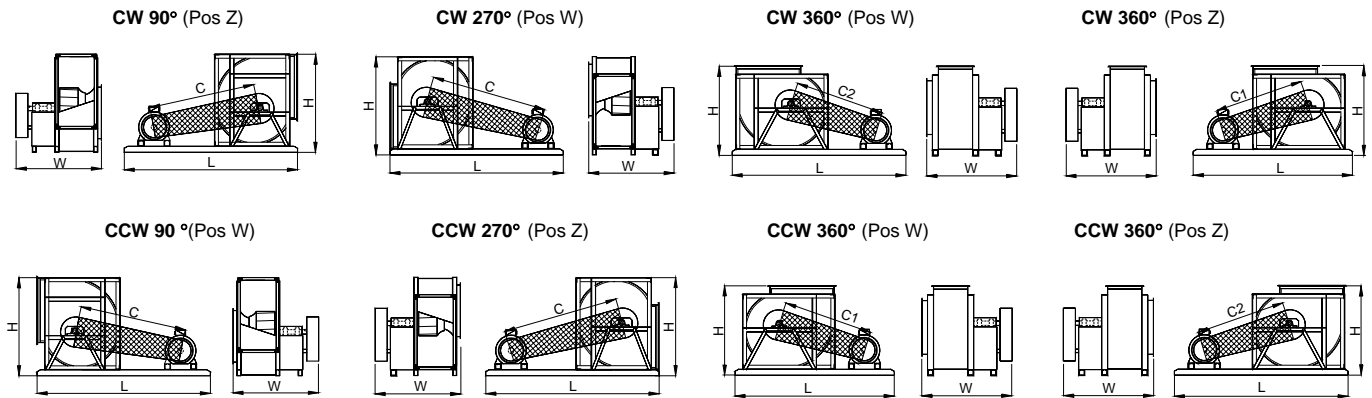

Model	Motor Frame Size	90°/ 270°							360°					
		C (90°)	C (270°)	L	W	H	* Wt (kg) 90°	* Wt (kg) 270°	C1	C2	L	W	H	* Wt (kg)
900	112	1169	1325	1800	1390	1728	354	363	1403	1133	2150	1390	1488	371
	132	1189	1338	1850	1390	1728	355	364	1421	1148	2200	1390	1488	371
	160	1293	1425	2000	1390	1728	357	367	1476	1197	2300	1390	1488	373
	180	1315	1441	2050	1390	1728	358	368	1543	1260	2400	1390	1488	375
	200	1385	1501	2150	1390	1728	360	369	1564	1278	2450	1390	1488	376
	225	1451	1557	2250	1390	1728	362	371	1627	1338	2550	1390	1488	378
	250	1518	1615	2350	1390	1728	364	373	1692	1399	2650	1390	1488	380
1000	132	1305	1475	2000	1478	1890	402	409	1532	1236	2350	1478	1620	423
	160	1361	1518	2100	1478	1890	404	411	1586	1282	2450	1478	1620	425
	180	1429	1575	2200	1478	1890	406	412	1651	1343	2550	1478	1620	427
	200	1451	1591	2250	1478	1890	407	413	1719	1405	2650	1478	1620	428
	225	1515	1644	2350	1478	1890	409	415	1781	1463	2750	1478	1620	430
	250	1581	1700	2450	1478	1890	411	417	1844	1523	2850	1478	1620	432
	280	1690	1796	2600	1478	1890	413	420	1903	1579	2950	1478	1620	434
1120	132	1423	1615	2150	1740	2158	738	738	1695	1356	2550	1740	1850	754
	160	1479	1658	2250	1740	2158	742	742	1749	1403	2650	1740	1850	758
	180	1547	1715	2350	1740	2158	746	746	1815	1464	2750	1740	1850	762
	200	1616	1773	2450	1740	2158	750	750	1836	1482	2800	1740	1850	764
	225	1680	1827	2550	1740	2158	754	754	1945	1585	2950	1740	1850	770
	250	1746	1882	2650	1740	2158	758	758	2008	1645	3050	1740	1850	774
	280	1806	1932	2750	1740	2158	762	762	2067	1700	3150	1740	1850	778
1250	132	1575	1805	2350	1869	2410	1094	1094	1884	1504	2800	1869	2055	1127
	160	1629	1846	2450	1869	2410	1101	1101	1937	1550	2900	1869	2055	1134
	180	1696	1900	2550	1869	2410	1109	1109	2002	1608	3000	1869	2055	1141
	200	1717	1914	2600	1869	2410	1119	1112	2068	1669	3100	1869	2055	1148
	225	1779	1965	2700	1869	2410	1119	1119	2129	1725	3200	1869	2055	1155
	250	1842	2017	2800	1869	2410	1127	1127	2190	1782	3300	1869	2055	1163
	280	1901	2064	2900	1869	2410	1134	1134	2247	1835	3400	1869	2055	1170
1400	160	1796	2050	2700	2086	2693	1446	1446	2148	1720	3200	2086	2295	1482
	180	1815	2062	2750	2086	2693	1449	1449	2212	1778	3300	2086	2295	1489
	200	1881	2115	2850	2086	2693	1456	1456	2232	1794	3350	2086	2295	1492
	225	1942	2164	2950	2086	2693	1464	1464	2291	1848	3450	2086	2295	1500
	250	2004	2214	3050	2086	2693	1471	1471	2352	1903	3550	2086	2295	1507
	280	2060	2259	3150	2086	2693	1478	1478	2408	1954	3650	2086	2295	1514
	315	2160	2343	3300	2086	2693	1489	1489	2505	2046	3800	2086	2295	1525

* The above weight does not include motor and drive unit as these will vary with supplier.

All Dimensions in mm.

Operational Limits - "ASA"

		315	355	400	450	500	560	630	710	800	900	1000	1120	1250	1400
Maximum Absorbed Power	C	2	3	3	4	5	6	7							
	T	5	6	7	9	11	13	16	10	12	15	18	25	25	35
	X	10	11	14	17	20	26	32	20	25	32	38	50	55	75
	UI	2	3	3	4	5	6	7	10	10	12	15	25	25	35
	UII	5	6	7	9	11	13	16	20	25	32	38	50	55	75
	UIII	10	11	14	17	20	26	32	40	50	65	76	100	110	150
Maximum Fan Speed	C	3350	2800	2500	2200	1950	1700	1550							
	T	4300	3600	3250	2850	2550	2250	2000	1350	1200	1050	950	850	750	650
	X	5400	4550	4100	3600	3200	2800	2500	1750	1550	1400	1250	1100	1000	850
	UI	3350	2800	2500	2200	1950	1700	1550	1350	1200	1050	950	850	750	650
	UII	4300	3600	3250	2850	2550	2250	2000	1750	1550	1400	1250	1100	1000	850
	UIII	5400	4550	4100	3600	3200	2800	2500	2250	2000	1750	1550	1400	1250	1100
Temperature Range / Min. -20°C	C	85	85	85	85	85	85	85							
	T	100	100	100	100	100	100	100	100	100	100	100	100	100	100
	X	100	100	100	100	100	100	100	100	100	100	100	100	100	100
	UI	180	180	180	180	180	180	180	180	180	180	180	180	180	180
	UII	180	180	180	180	180	180	180	180	180	180	180	180	180	180
	UIII	180	180	180	180	180	180	180	180	180	180	180	180	180	180
Fan weight	C	19	24	32	41	53	76	101							
	T	33	48	58	70	87	123	152	189	228	286	331	575	767	1049
	X	35	50	59	72	89	126	154	192	232	290	338	586	780	1069
	UI	32	44	54	67	81	112	140	180	250	312	359	601	831	1140
	UII	33	45	54	68	82	113	142	182	252	315	362	606	837	1153
	UIII	33	45	54	68	82	113	142	182	252	315	362	606	837	1153



Centrifugal Fan Ordering Information

Fan Details	
<input type="checkbox"/> Fan type	<input type="checkbox"/> DIDW <input type="checkbox"/> SISW
<input type="checkbox"/> Impeller type	<input type="checkbox"/> Forward Curved <input type="checkbox"/> Backward Curved <input type="checkbox"/> Others : _____ (Please State)
<input type="checkbox"/> Model & size e.g. FSA 560 C	<input type="checkbox"/> Model : _____ (If known)
<input type="checkbox"/> Drive type - belt, direct, coupling (if differ from standard)	<input type="checkbox"/> Belt <input type="checkbox"/> Direct <input type="checkbox"/> Coupling <input type="checkbox"/> Others : _____ (Please State)
<input type="checkbox"/> Arrangement (1 & 3 for bare shaft fan; 4, 8 & 12 for complete with drive system)	<input type="checkbox"/> Bare fan <input type="checkbox"/> Complete with drive system
<input type="checkbox"/> Rotation & Discharge e.g. CCW 270	<input type="checkbox"/> CW <input type="checkbox"/> CCW <input type="checkbox"/> 90 <input type="checkbox"/> 180 <input type="checkbox"/> 270 <input type="checkbox"/> 360
<input type="checkbox"/> Motor position (refer to diagram) e.g. W	<input type="checkbox"/> W <input type="checkbox"/> X <input type="checkbox"/> Y <input type="checkbox"/> Z
<input type="checkbox"/> Air Flow Rate	Q : _____ <input type="checkbox"/> L/S <input type="checkbox"/> m ³ /h <input type="checkbox"/> m ³ /min <input type="checkbox"/> m ³ /s <input type="checkbox"/> cfm
<input type="checkbox"/> Pressure (static & total)	SP : _____ TP : _____ <input type="checkbox"/> Pa <input type="checkbox"/> mmH ₂ O <input type="checkbox"/> inWG
<input type="checkbox"/> Fan RPM (if specified)	Max. : _____ Min. : _____
<input type="checkbox"/> Noise level	<input type="checkbox"/> dB <input type="checkbox"/> dBA Lw : _____ Lp : _____ at Distance : _____ m <input type="checkbox"/> free field <input type="checkbox"/> room condition <input type="checkbox"/> corner / wall
<input type="checkbox"/> Ambient temperature	<input type="checkbox"/> Temp. : _____ °C
<input type="checkbox"/> Air density, if differ from standard	<input type="checkbox"/> Density : _____ kg/m ³ <input type="checkbox"/> Altitude : _____ m
Motor Details	Fittings Detail
<input type="checkbox"/> Power	<input type="checkbox"/> Accessories <input type="checkbox"/> Inspection door <input type="checkbox"/> Drain plug <input type="checkbox"/> Flexible duct <input type="checkbox"/> Inlet vane control <input type="checkbox"/> Vibration Isolators: <input type="checkbox"/> Rubber <input type="checkbox"/> Spring <input type="checkbox"/> Floor-mount <input type="checkbox"/> Ceiling-hang <input type="checkbox"/> Silencers : <input type="checkbox"/> With pod <input type="checkbox"/> Without pod <input type="checkbox"/> Inlet <input type="checkbox"/> Outlet <input type="checkbox"/> Both inlet & outlet <input type="checkbox"/> Counter-flanges : <input type="checkbox"/> Flat <input type="checkbox"/> L-type <input type="checkbox"/> U-type <input type="checkbox"/> Inlet <input type="checkbox"/> Outlet
<input type="checkbox"/> kW : _____ <input type="checkbox"/> HP : _____	
<input type="checkbox"/> No. of Poles / RPM	
<input type="checkbox"/> Voltage	
<input type="checkbox"/> Phase	Special Features
<input type="checkbox"/> 1φ <input type="checkbox"/> 3φ	
<input type="checkbox"/> Frequency	
<input type="checkbox"/> 50 Hz <input type="checkbox"/> 60 Hz	
<input type="checkbox"/> Frame size	<input type="checkbox"/> Painting <input type="checkbox"/> Powder coating <input type="checkbox"/> Hot-dipped galvanizing
<input type="checkbox"/> IEC : _____ <input type="checkbox"/> NEMA : _____ <input type="checkbox"/> Others : _____	<input type="checkbox"/> Other Requirements <input type="checkbox"/> Spark-resistant <input type="checkbox"/> Corrosion-resistant <input type="checkbox"/> Heat-resistant, temp. _____ °C <input type="checkbox"/> Smoke Spill, Max. temp. _____ °C for _____ Hr
<input type="checkbox"/> Make, if specified	
<input type="checkbox"/> Brand : _____ <input type="checkbox"/> Mfr. : _____ <input type="checkbox"/> Country : _____	

KRUGER GROUP (VENTILATION)

• THAILAND (Regional HQ)

KRUGER VENTILATION INDUSTRIES ASIA CO. LTD.

30/159 Moo 1, Sinsakorn Industrial Estate,
Chetsadawithi Road, Khok Kham Mueng, Samuthsakorn 74000, Thailand
Tel. +662 1054298 - Fax +662 0248256-9
Website: www.krugerfan.com

• CHINA (BEIJING)

BEIJING KRUGER VENTILATION CO. LTD

Level 7, A Block, Rising International Building, 29 JingHai San Road, BDA,
Beijing, P.R.China 100176
Tel. +86 10-67881366 - Fax +86 10-67880566
Email: krugertj@krugertj.com

• CHINA (SHANGHAI)

SHANGHAI KRUGER VENTILATION CO. LTD

No. 500 Yuanguo Road, Anting, Jiading,
Shanghai 201814 P.R. China
Tel. +86 21-69573266 - Fax +86 21-69573296
Email: shkruger@krugerchina.com

• CHINA (WUHAN)

WUHAN KRUGER VENTILATION CO. LTD

No. 805, Huian Ave, Dongxihu District, Wuhan, Hubei, P.R. China 430000
Tel. +86 27- 83248840/83060522/83097505
Fax +86 27- 83261886
Email: whkruger@krugerwh.com

• HONG KONG

KRUGER VENTILATION (HONG KONG) LIMITED

Flat C, 9/F, Yeung Yiu Chung (No.8) Industrial Building,
20 Wang Hoi Road, Kowloon Bay, Kowloon, Hong Kong
Tel. +852 22469182 - Fax. +852 22469187
Email: info@kruger.com.hk

• INDIA (NORTH)

KRUGER VENTILATION INDUSTRIES (NORTH INDIA) PVT LTD

Plot No. - 191, Sector - 59, Ballabgarh, Faridabad - 121 004, Haryana, India
Tel. +91-9958991660/9717449696
Fax. +91-1294135820
Email: sales.kni@krugerindia.com

• KOREA

NEOMATE CO. LTD

2-1010, Ace High Tech City B/D, 775 Gyeongin-ro,
Yeongdeungpo-gu, Seoul, Korea. Postal Code 07299
Tel. +82-2-2679-2052 - Fax. +82-2-2679-2174
Email: y7890@neomate.co.kr

• MYANMAR

KRUGER VENTILATION (MYANMAR) CO.LTD

Room No. F21, Thiri Yadanar Whole Sale Market, (Htawunbe)
Toe Chae Ward, North Okkalapa Township, Yangon.
Tel. +959 763141081/2/3
Email: htoon@krugermm.com

• SINGAPORE

KRUGER ENGINEERING PTE LTD

No. 10 Buroh Street #06-06, West Connect Building,
Singapore 627564
Tel. +65 68631191 - Fax +65 68631151
Email: mktg@krugerasia.com

• THAILAND

KRUGER VENTILATION IND. (THAILAND) CO. LTD

30/105 Moo 1, Sinsakorn Industrial Estate,
Chetsadawithi Road, Khok Kham Mueng, Samuthsakorn 74000, Thailand
Tel. +662 1050399 - Fax + 662 1050370-2
Email: mktg@kruger.co.th

• AUSTRALIA

S&P-KRUGER AUSTRALIA PTY LTD

2 Cunningham St, Moorebank N.S.W. 2170
Tel. +61 2-98227747
Fax. +61 2-98227757
Email: info@sandpkruuger.com.au

• CHINA (GUANGZHOU)

GUANGZHOU KRUGER VENTILATION CO. LTD

No. 9 Huahui Road, Huashan, Huadu,
Guangzhou, P.R. China 510880
Tel. +86 20-66356635 - Fax +86 20-86786001/86786500
Email: gzkruuger@krugergz.com

• CHINA (TIANJIN)

TIANJIN KRUGER VENTILATION CO. LTD

No.168 Anyuan Road, Jingjin Science and Technology Park
Wuqing District, Tianjin, China
Tel. +86 22-22143480/3481 - Fax +86 22-22143482
Email: krugertj@krugertj.com

• DUBAI

KRUGER VENTILATION INDUSTRIES, GULF BRANCH

Jebel Ali Free Zone Area (JAFZA) P.O. Box No. 262949, Dubai, UAE
Tel. +971 4 8819188/8832017
Fax. +971 4 8832018
Email: johncs@krugerasia.com

• INDIA

KRUGER VENTILATION INDUSTRIES (INDIA) PVT LTD

Kruger Centre, Mumbai-Nasik Highway,
Kalamgaon, Shahapur, Thane 421601, Maharashtra, India
Tel. +91 9960558899/9975577211 - Fax +91 2527 240075
Email: sales@krugerindia.com

• INDONESIA

P.T. KRUGER VENTILATION INDONESIA

JL. Teuku Umar No.20,
Karawaci - Tangerang 15115, Indonesia
Tel. +62 21-5512288/5513557 - Fax +62 21-5513502
Email: mktg@krugerindo.co.id

• MALAYSIA

KRUVENT INDUSTRIES (M) SDN BHD

Lot 850, Jalan Subang 7, Taman Perindustrian Subang,
47500, Subang Jaya, Selangor D.E.
Tel. +603 80743399 - Fax +603 80743388
Email: mktg@kruger.com.my

• PHILIPPINES

KRUGER M&E INDUSTRIES CORPORATION

FAPI Compound, E. Rodriguez Ave.
Tunasan, Muntinlupa City 1773, Philippines
Tel. +63 2-8622892/4/6/7, 5534059 - Fax +63 2-8622891
Email: mktg@krugerph.net

• TAIPEI

KRUGER VENTILATION (TAIWAN) CO. LTD

No. 157, Ping-an Rd, Hengfeng Village,
Dayuan Shiang Taoyuan County 337, Taiwan
Tel. +886 3-3859119 - Fax +886 3-3859118
Email: sales@krugertwn.com.tw

• VIETNAM

KRUGER VENTILATION INDUSTRIES (VIETNAM) CO. LTD

Lot A7. 2-4, C2 Road, Thanh Thanh Cong IZ,
Trang Bang Dist. Tay Ninh Province, Vietnam
Tel. +84-276 3585200/01/02 - Fax +84-276 3585199
Email: mktg@krugervn.com

The company is always improving and developing its products, therefore the company reserves the right of making changes to the illustrated products.
Certified dimension can be provided upon request.

Kruger Ventilation Industries Asia Co., Ltd

30/159 Moo 1, Sinsakorn Industrial Estate
Chetsadawithi Road, Khok Kham Mueng,
Samuthsakorn 74000, Thailand
Tel. +662 1054298 - Fax. +0248256-9
Website: www.krugerfan.com

CNo. - CAT010.E2 March 2018

A member of
Soler&Palau
Ventilation Group

The logo for Soler&Palau Ventilation Group features a stylized red and white circular graphic element to the right of the text.