

# Wall Mount Type

# Ventilating Fan



## FV-20LUT3 / FV-25LUT3 / FV-30LUT1

Automatic Shutter Series

## FV-20RLT2 / FV-25RLT2 / FV-30RLT1

Reversible Series

- HP condenser motor with thermal cut-off
- Well lubricated bearing for long life operation
- Propeller fan incorporated with advanced blade design (except FV-30LUT1 and FV-30RLT1)
- For reversible series, on-off and reversible function operated by pull cord switch

## Dimension

Unit : mm

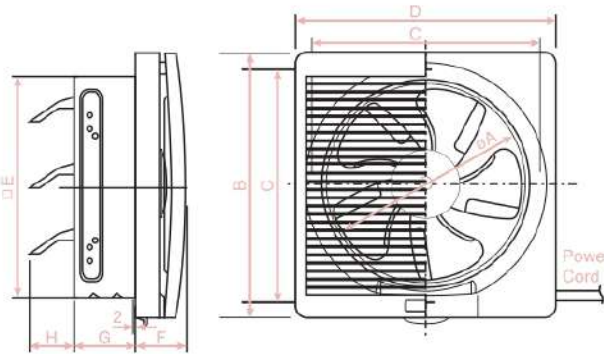

Model No.	A	B	C	D	E	F	G	H
FV-20LUT3	200	306	260	302	240	68	90	80
FV-25LUT3	250	356	310	352	290	63	90	63
FV-30LUT1	300	406	360	402	340	63	90	78
FV-20RLT2	200	306	260	302	240	68	90	80
FV-25RLT2	250	356	310	352	290	63	90	63
FV-30RLT1	300	406	360	402	340	63	90	78

## Specification

Model	Air Volume		Input (W)	Speed (rpm)	Noise (dB(A))	Weight (Kg.)	Grill Size W x L (mm.)	Installation space W x L (mm.)
	CMH	CFM						
FV-20LUT3	546	321	20	1,190	40	2.2	302 x 306	250 x 250
FV-25LUT3	835	491	27	1,060	43	2.7	352 x 356	300 x 300
FV-30LUT1	930	547	31	820	43	3.1	402 x 406	350 x 350
FV-20RLT2	EX	546	321	20	1,240	39	302 x 306	250 x 250
	IN	370	218	15	1,190	46		
FV-25RLT2	EX	840	494	29	1,040	43	352 x 356	300 x 300
	IN	580	341	21	1,035	45		
FV-30RLT1	EX	990	583	33	880	44	402 x 406	350 x 350
	IN	594	349	24	776	43		

Note: The value in Specification tables are representative characteristic value at 220V, 50Hz.  
R.P.M. data is for reference only, values may vary subject to different conditions.  
The noise level is measured at 1 meter from fan.