

Wall Mount Type

Entry Bath Fan



FV-10EGS1T / FV-15EGS1T

Shutter Series (for Vertical Shaft)

- Powerful exhaust of moisture and smell
- Compact and stylish design
- Back draft shutter
- All accessories are included for most convenience
- Easy installation

Dimension

Unit : mm

Model	A	B	C	D	E	F	G
FV-10EGS1T	176	170	9.3	177	160	115	40
FV-15EGS1T	230	220	11.5	230	160	160	80

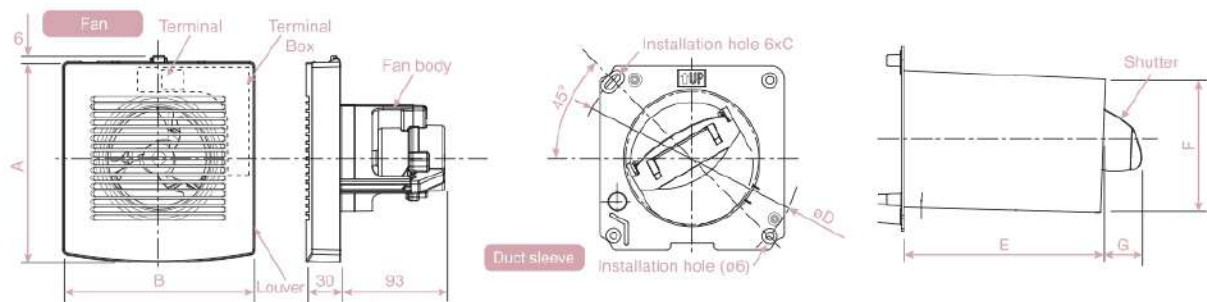

FV-10EGK1T / FV-15EGK1T

Rain Hood Series

- Powerful exhaust of moisture and smell
- Compact and stylish design
- Prevent trace caused by rain water
- All accessories are included for most convenience
- Easy installation
- Wall thickness 100-150mm

Dimension

Unit : mm

Model	A	B	C	D	E	F	G	H	I
FV-10EGK1T	176	170	9.3	177	250	220	107	99	120
FV-15EGK1T	230	220	11.5	221	310	270	142	138	165

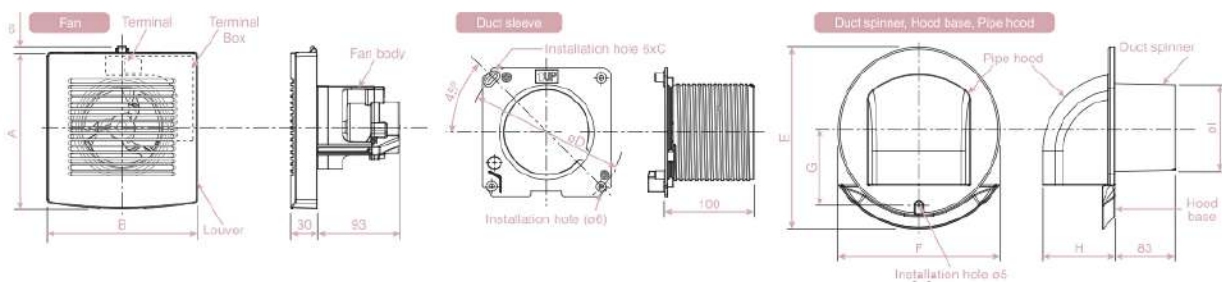

Specification

Model	Air Volume		Input (W)	Speed (rpm)	Noise (dB(A))	Weight (Kg.)	Grill Size W x L (mm.)	Installation Space W x L (mm.)
	CMH	CFM						
FV-10EGS1T	75	44	5.5	2,706	35	0.9	170 x 176	Ø120 -125
FV-15EGS1T	150	88	6.2	2,329	36	1.1	220 x 230	Ø165 -170
FV-10EGK1T	75	44	5.5	2,706	33	1.2	170 x 176	Ø135 ±5
FV-15EGK1T	160	94	6.2	2,329	34	1.5	220 x 230	Ø180 ±5

Note: The value in Specification tables are representative characteristic value at 220V, 50Hz.
R.P.M. data is for reference only, values may vary subject to different conditions.
The noise level is measured at 1 meter from fan.