



KDD Series

Double Inlet Direct Driven Centrifugal Fan



Double Inlet Direct Driven Centrifugal Fan - KDD SERIES



- DIDW direct driven centrifugal fans with forward curved impellers suitable for AHU, FCU and other OEM product requirement.
- The housing is manufactured in galvanized sheet steel with the housing constructed by means of “electric spot welding”.
- Forward curved wheel is made of galvanized sheet steel.
- The wheels are specially profiled to obtain a maximum efficiency and low noise level.
- Operating Temperature:-20°C to +40°C.

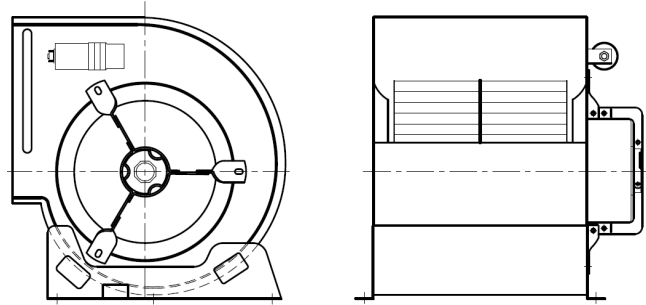

Technical Data

Model	Max Q (m³/h)	Installed Power (W)	Motor Protection	Phase	Pole	Hz	Maximum Current (A)	Voltage (V)	Capacitor (µF/V)	Insulation Class	Lp (A) at 3m free discharge (dB (A))*	Speed (RPM)	Wiring Diagram (Page 4)
KDD 7/7 165W 4P-1 1S	1700	165	IP20	1	4	50	1.4	220	7.5/450	F	49	1250	1 or 2
KDD 8/8 165W 4P-1 1S	1600	165	IP20	1	4	50	1.5	220	7.5/450	F	48	1050	1 or 2
KDD 9/7 350W 4P-1 3S	2620	350	IP20	1	4	50	4.9/4.1/3.3	220	12.5/450	F	55	1130/1030/960	5 or 6
KDD 9/7 375W 6P-1 3S	2840	375	IP20	1	6	50	3.0/2.0/1.7	230	20/450	F	54	950/860/770	5 or 6
KDD 9/7T 350W 4P-1 3S	2430	350	IP20	1	4	50	4.6/3.7/3.2	220	12.5/450	F	57	1170/1070/990	5 or 6
KDD 9/9 375W 6P-1 3S	3120	375	IP20	1	6	50	3.7/2.9/2.2	220	7.5/450	F	55	910/810/720	5 or 6
KDD 9/9 550W 4P-1 3S	3530	550	IP20	1	4	50	6.5/4.4/3.9	220	16/450	F	60	1200/1160/1090	5 or 6
KDD 9/9T 550W 4P-1 3S	3600	550	IP20	1	4	50	5.9/5.3/4.4	230	16/450	F	60	1260/1170/1110	5 or 6
KDD 10/8 375W 6P-1 3S	3240	375	IP20	1	6	50	3.7/2.9/2.2	220	12.5/450	F	53	830/720/650	5 or 6
KDD 10/10 245W 6P-1 3S	3040	245	IP20	1	6	50	4.5/2.9/1.7	220	20/450	F	55	840/660/630	5 or 6
KDD 10/10 375W 6P-1 3S	3550	375	IP20	1	6	50	3.9/2.8/2.3	220	12.5/450	F	51	830/730/700	5 or 6
KDD 10/10 550W 4P-1 3S	3650	550	IP20	1	4	50	6.5/5.2/4.4	230	16/450	F	58	1100/1040/1020	5 or 6
KDD 10/10T 550W 4P-1 3S	3440	550	IP20	1	4	50	6.7/5.5/4.4	230	16/450	F	56	1120/1020/960	5 or 6
KDD 9/7 350W 4P-1 3S6	2230	350	IP20	1	4	60	4.5/3.4/2.8	220	16/450	F	56	1220/1160/1110	3 or 4
KDD 9/9 350W 4P-1 3S6	2430	350	IP20	1	4	60	3.9/3.1/2.5	220	16/450	F	56	1140/1110/1090	3 or 4
KDD 10/8 550W 6P-1 3S6	3930	550	IP20	1	6	60	6.3/4.3/3.6	220	16/450	F	60	1010/880/850	5 or 6
KDD 10/10 550W 6P-1 3S6	3940	550	IP20	1	6	60	6.0/4.9/3.8	220	16/450	F	57	930/890/730	5 or 6

* Inlet Lp(A) sound pressure levels at 3m are measured at free discharge in spherical free field condition, inlet Lp(A) (dB(A)) levels are not licensed by AMCA International.
 - Performance shown is for installation type B – Free inlet, Ducted outlet.
 - Performance ratings do not include the effects of appurtenances (accessories).
 - Speed (RPM) shown is nominal. Performance is based on actual speed of test.

Performance Data - 50 Hz

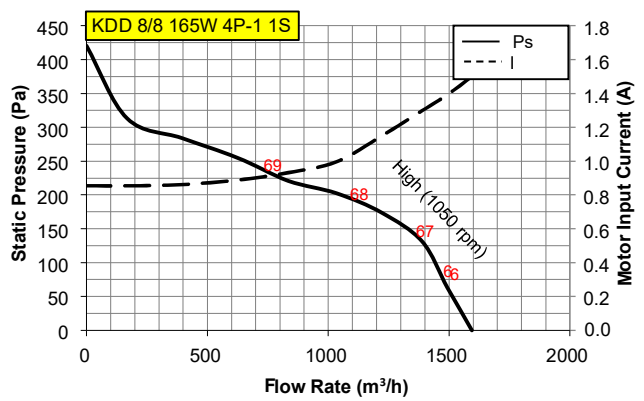
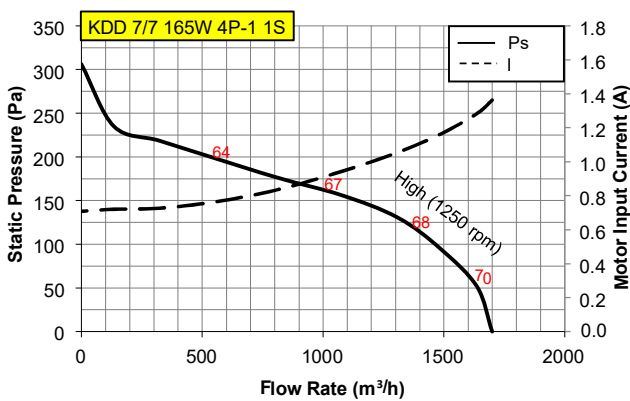

- Values shown are for inlet Lwi(A) sound power levels for installation type B – Free inlet, Ducted outlet. The A-weighted sound ratings shown have been calculated per AMCA International Standard 301.
 - Performance shown is for installation type B – Free inlet, Ducted outlet.
 - Performance ratings do not include the effects of appurtenances (accessories).
 - Speed (RPM) shown is nominal. Performance is based on actual speed of test.

Double Inlet Direct Driven Centrifugal Fan - KDD SERIES



Performance Data - 50 Hz

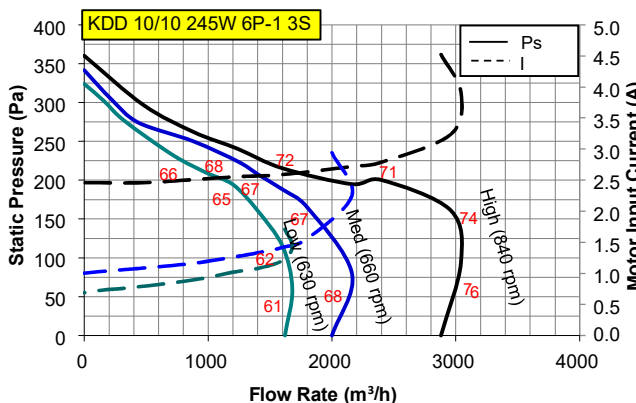
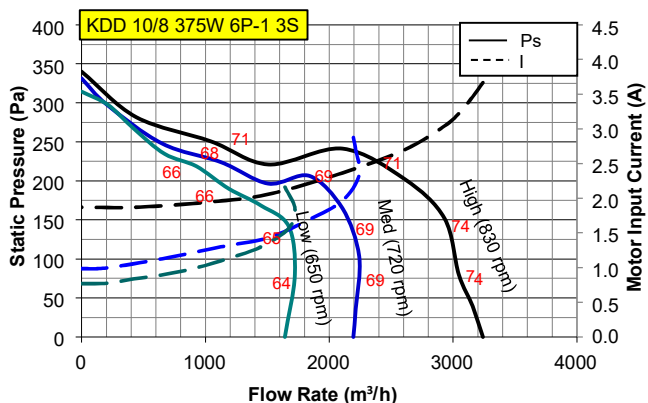
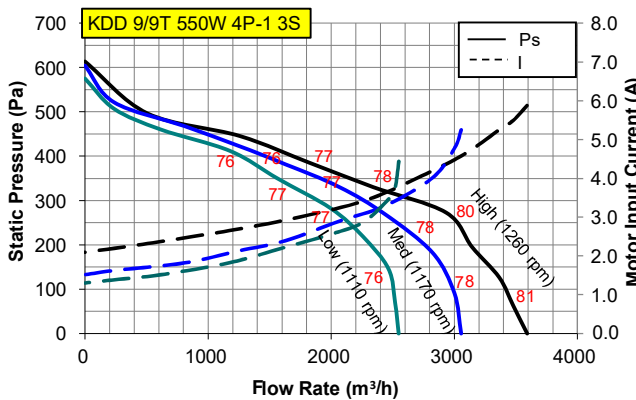
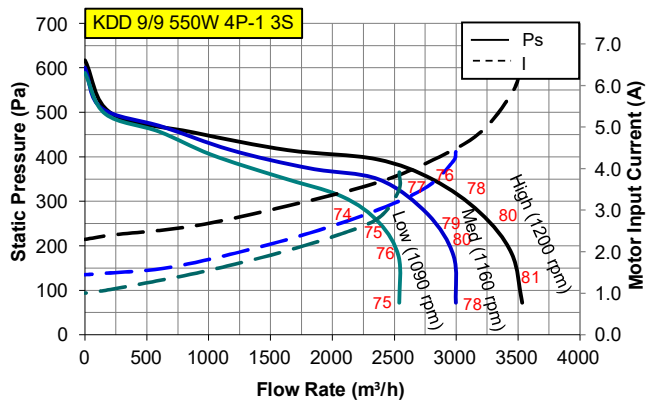
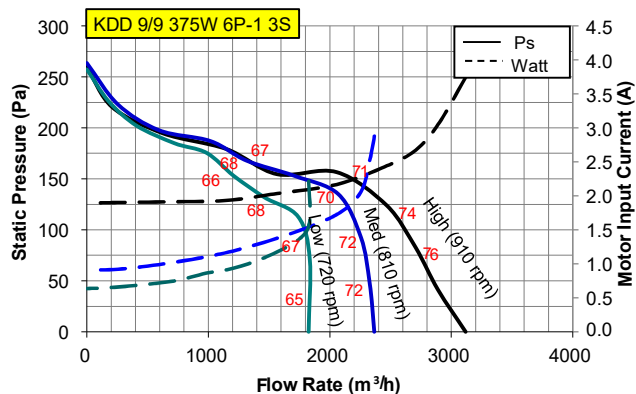
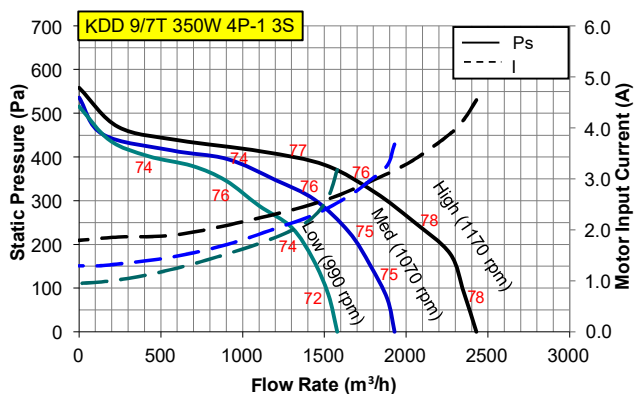
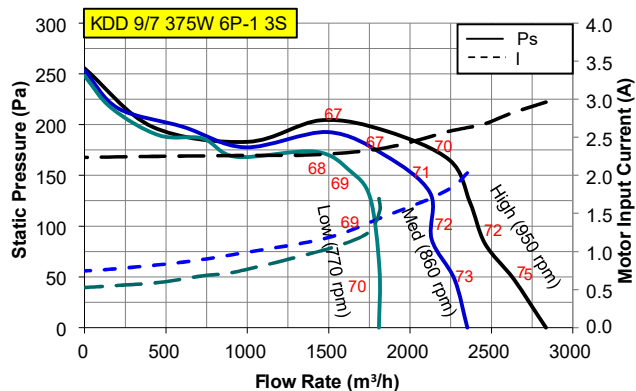
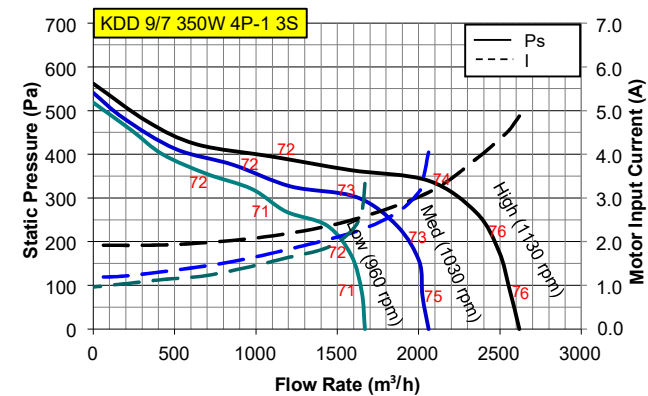

- Values shown are for inlet Lwi(A) sound power levels for installation type B – Free inlet, Ducted outlet. The A-weighted sound ratings shown have been calculated per AMCA International Standard 301.
- Performance shown is for installation type B – Free inlet, Ducted outlet.
- Performance ratings do not include the effects of appurtenances (accessories).
- Speed (RPM) shown is nominal. Performance is based on actual speed of test.

Double Inlet Direct Driven Centrifugal Fan - KDD SERIES

Performance Data - 50 Hz

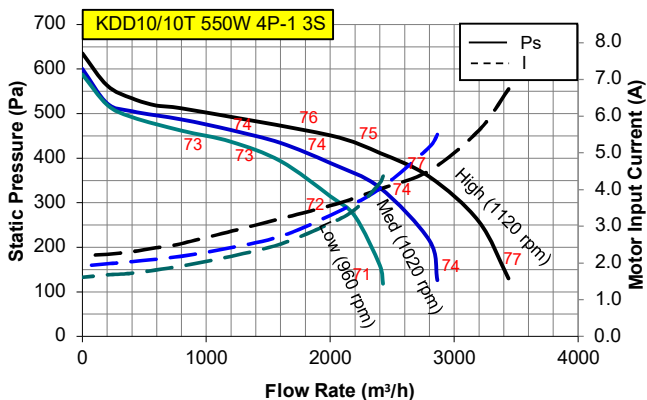
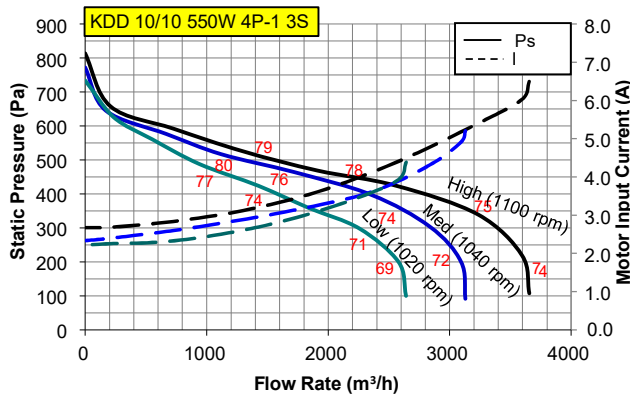
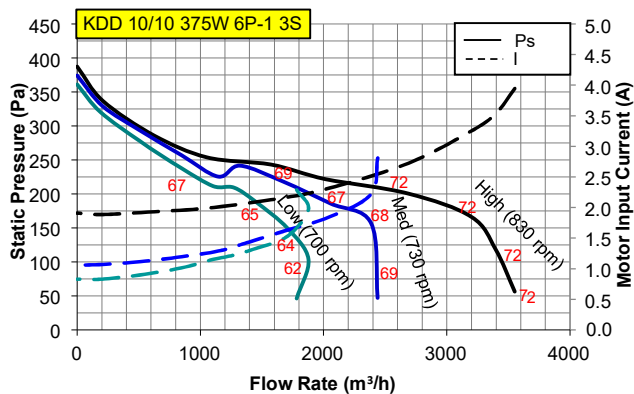

Performance Data - 60 Hz

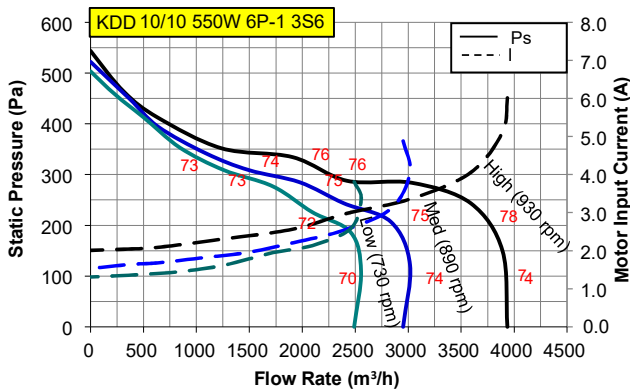
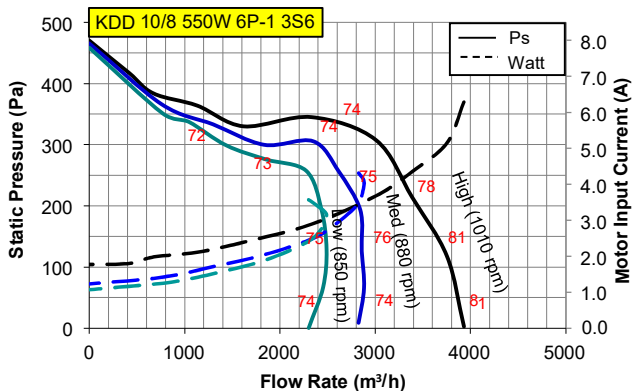
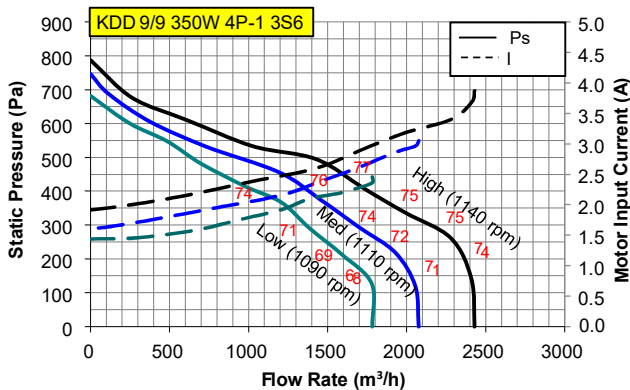
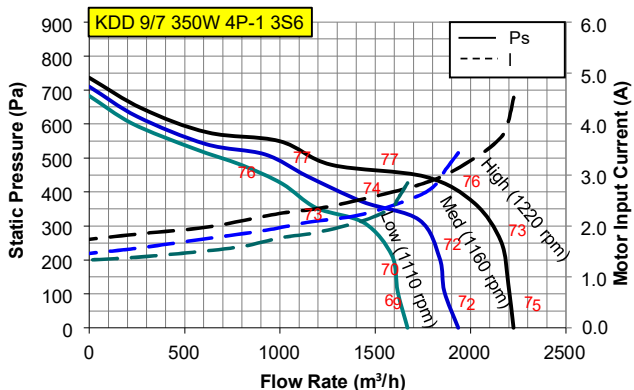

- Values shown are for inlet Lwi(A) sound power levels for installation type B – Free inlet, Ducted outlet. The A-weighted sound ratings shown have been calculated per AMCA International Standard 301.
- Performance shown is for installation type B – Free inlet, Ducted outlet.
- Performance ratings do not include the effects of appurtenances (accessories).
- Speed (RPM) shown is nominal. Performance is based on actual speed of test.

Double Inlet Direct Driven Centrifugal Fan - KDD SERIES

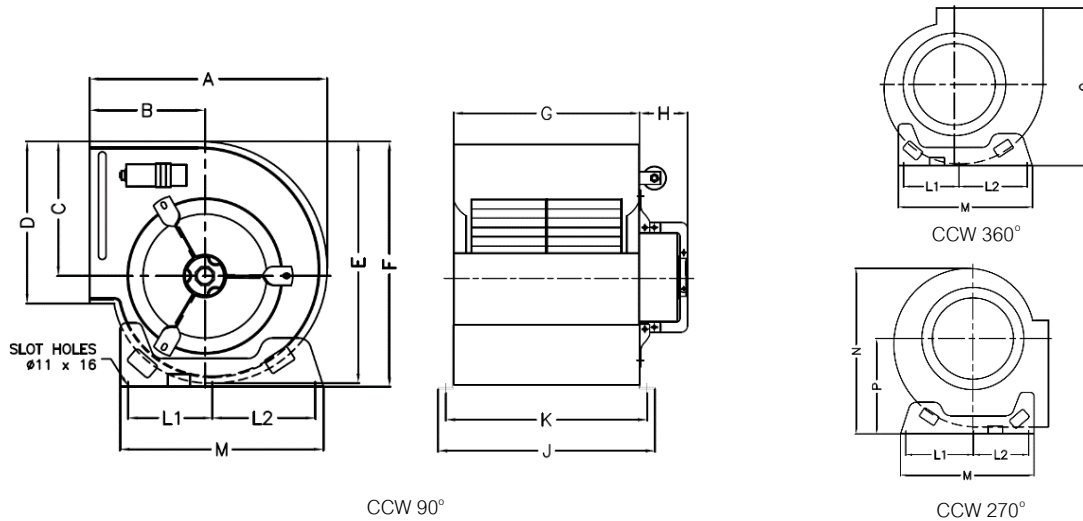

Dimension

Model	A	B	C	D	E	F	G	H	J	K	L1	L2	M	N	P	Q	Weight (kg)
KDD 7/7 165W 4P-1 1S	312	152	192	228	328	358	259	46	299	279	90	90	210	354	224	317	9
KDD 8/8 165W 4P-1 1S	345	164	216	256	364	397	287	50	337	312	112	112	254	393	246	348	11
KDD 9/7 350W 4P-1 3S	380	185	216	262	387	393	232	100	282	257	135	165	326	404	233	383	14
KDD 9/7 375W 6P-1 3S	380	185	216	262	387	393	232	100	282	257	135	165	326	404	233	383	14
KDD 9/7T 350W 4P-1 3S	317	152	185	262	327	332	232	100	282	257	117	117	260	267	192	323	13
KDD 9/9 375W 6P-1 3S	380	185	216	262	387	393	298	75	348	323	135	165	326	404	233	383	16
KDD 9/9 550W 4P-1 3S	380	185	216	262	387	393	298	100	348	323	135	165	326	404	233	383	17
KDD 9/9T 550W 4P-1 3S	317	152	185	262	327	332	298	100	348	323	117	117	260	267	192	323	16
KDD 10/8 375W 6P-1 3S	425	203	249	289	443	448	265	75	315	290	170	170	366	481	287	431	16
KDD 10/10 245W 6P-1 3S	425	203	249	289	443	448	331	50	381	356	170	170	366	481	287	431	17
KDD 10/10 375W 6P-1 3S	425	203	249	289	443	448	331	75	381	356	170	170	366	481	287	431	20
KDD 10/10 550W 4P-1 3S	425	203	249	289	443	448	331	76	381	356	170	170	366	481	287	431	20
KDD 10/10T 550W 4P-1 3S	364	174	206	289	380	388	331	77	381	357	114	150	290	392	217	375	18
KDD 9/7 350W 4P-1 3S6	380	185	216	262	387	393	232	95	282	257	135	165	326	404	233	383	14
KDD 9/9 350W 4P-1 3S6	380	185	216	262	387	393	298	95	348	323	135	165	326	404	233	383	15
KDD 10/8 550W 6P-1 3S6	425	203	249	289	443	448	265	100	315	290	170	170	366	481	287	431	18
KDD 10/10 550W 6P-1 3S6	425	203	249	289	443	448	331	75	381	356	170	170	366	481	287	431	20

- All dimension in mm.
 - For CW rotation, all dimension will be mirrored.

Wiring Diagrams

CCW 90°, 270°, 360°

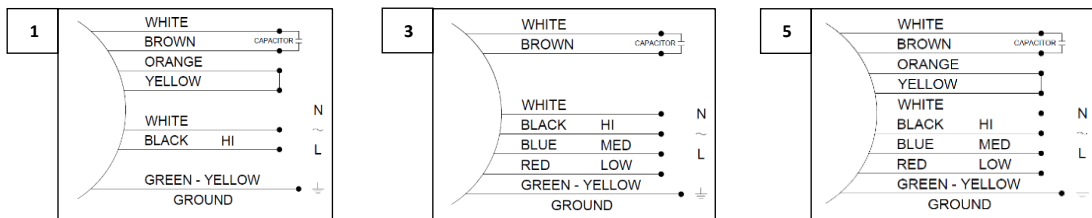

CW 90°, 270°, 360°

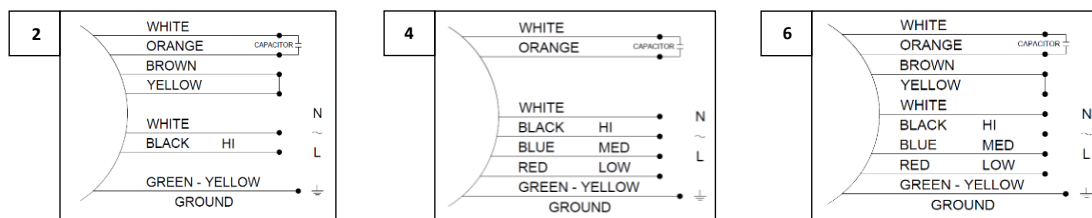

KRUGER GROUP (VENTILATION)

● THAILAND (Regional HQ)

KRUGER VENTILATION INDUSTRIES ASIA CO. LTD.
30/159 Moo 1, Sinsakorn Industrial Estate,
Chetsadawithi Road, Khok Kham Mueng, Samuthsakorn 74000, Thailand
Tel. +662 1054298 - Fax +662 0248256 to 9
Website: www.krugerfan.com

● CHINA (BEIJING)

BEIJING KRUGER VENTILATION CO. LTD
Level 7, A Block, Rising International Building, 29 JingHai San Road, BDA,
Beijing, P.R.China 100176
Tel. +86 10-67881366 - Fax +86 10-67880566
Email: krugertj@krugertj.com

● CHINA (SHANGHAI)

SHANGHAI KRUGER VENTILATION CO. LTD
No. 500 Yuanguo Road, Anting, Jiading,
Shanghai 201814 P.R. China
Tel. +86 21-69573266 - Fax +86 21-69573296
Email: shkruger@krugerchina.com

● CHINA (WUHAN)

WUHAN KRUGER VENTILATION CO. LTD
No. 805, Huian Ave, Dongxihu District, Wuhan, Hubei, P.R. China 430000
Tel. +86 27- 83248840/83060522/83097505
Fax +86 27- 83261886
Email: whkruger@krugerwh.com

● HONG KONG

KRUGER VENTILATION (HONG KONG) LIMITED
Flat C, 9/F, Yeung Yiu Chung (No.8) Industrial Building,
20 Wang Hoi Road, Kowloon Bay, Kowloon, Hong Kong
Tel. +852 22469182 - Fax +852 22469187
Email: info@kruger.com.hk

● INDIA (NORTH)

KRUGER VENTILATION INDUSTRIES (NORTH INDIA) PVT LTD
Plot No. - 191, Sector - 59, Ballabgarh, Faridabad - 121 004, Haryana, India
Tel. +91-9958991660/9717449696
Fax. +91-1294135820
Email: sales.kni@krugerindia.com

● KOREA

NEOMATE CO. LTD
2-1010, Ace High Tech City B/D, 775 Gyeongin-ro,
Yeongdeungpo-gu, Seoul, Korea. Postal Code 07299
Tel. +82-2-2679-2052 - Fax. +82-2-2679-2174
Email: y7890@neomate.co.kr

● MYANMAR

KRUGER VENTILATION (MYANMAR) CO.LTD
Room No. F21, Thiri Yadanar Whole Sale Market, (Htawunbe)
Toe Chae Ward, North Okkalapa Township, Yangon.
Tel. +959 763141081/2/3
Email: htoon@krugermm.com

● SINGAPORE

KRUGER ENGINEERING PTE LTD
No. 10 Buroh Street #06-06, West Connect Building,
Singapore 627564
Tel. +65 68631191 - Fax +65 68631151
Email: mktg@krugerasia.com

● THAILAND

KRUGER VENTILATION IND. (THAILAND) CO. LTD
30/105 Moo 1, Sinsakorn Industrial Estate,
Chetsadawithi Road, Khok Kham Mueng, Samuthsakorn 74000, Thailand
Tel. +662 1050399 - Fax + 662 1050370-2
Email: mktg@kruger.co.th

● AUSTRALIA

S&P-KRUGER AUSTRALIA PTY LTD
2 Cunningham St, Moorebank N.S.W. 2170
Tel. +61 2-98227747
Fax. +61 2-98227757
Email: info@sandpkruger.com.au

● CHINA (GUANGZHOU)

GUANGZHOU KRUGER VENTILATION CO. LTD
No. 9 Huahui Road, Huashan, Huadu,
Guangzhou, P.R. China 510880
Tel. +86 20-66356635 - Fax +86 20-86786001/86786500
Email: gzkruiger@krugergz.com

● CHINA (TIANJIN)

TIANJIN KRUGER VENTILATION CO. LTD
No.168 Anyuan Road, Jingjin Science and Technology Park
Wuqing District, Tianjin, China
Tel. +86 22-22143480/3481 - Fax +86 22-22143482
Email: krugertj@krugertj.com

● DUBAI

KRUGER VENTILATION INDUSTRIES, GULF BRANCH
Jebel Ali Free Zone Area (JAFZA) P.O. Box No. 262949, Dubai, UAE
Tel. +971 4 8819188/8832017
Fax. +971 4 8832018
Email: johncs@krugerasia.com

● INDIA

KRUGER VENTILATION INDUSTRIES (INDIA) PVT LTD
Kruger Centre, Mumbai-Nasik Highway,
Kalamgaon, Shahapur, Thane 421601, Maharashtra, India
Tel. +91 9960558899/9975577211 - Fax +91 2527 240075
Email: sales@krugerindia.com

● INDONESIA

P.T. KRUGER VENTILATION INDONESIA
JL. Teuku Umar No.20,
Karawaci - Tangerang 15115, Indonesia
Tel. +62 21-5512288/5513557 - Fax +62 21-5513502
Email: mktg@krugerindo.co.id

● MALAYSIA

KRUVENT INDUSTRIES (M) SDN BHD
Lot 850, Jalan Subang 7, Taman Perindustrian Subang,
47500, Subang Jaya, Selangor D.E.
Tel. +603 80743399 - Fax +603 80743388
Email: mktg@kruger.com.my

● PHILIPPINES

KRUGER M&E INDUSTRIES CORPORATION
FAPI Compound, E. Rodriguez Ave.
Tunasan, Muntinlupa City 1773, Philippines
Tel. +63 2-8622892/4/6/7, 5534059 - Fax +63 2-8622891
Email: mktg@krugerph.net

● TAIPEI

KRUGER VENTILATION (TAIWAN) CO. LTD
No. 157, Ping-an Rd, Hengfeng Village,
Dayuan Shiang Taoyuan County 337, Taiwan
Tel. +886 3-3859119 - Fax +886 3-3859118
Email: sales@krugertwn.com.tw

● VIETNAM

KRUGER VENTILATION INDUSTRIES (VIETNAM) CO. LTD
Lot A7. 2-4, C2 Road, Thanh Thanh Cong IZ,
Trang Bang Dist. Tay Ninh Province, Vietnam
Tel. +84-276 3585200/01/02 - Fax +84-276 3585199
Email: mktg@krugervn.com

The company is always improving and developing its products, therefore the company reserves the right of making changes to the illustrated products.
Certified dimension can be provided upon request.